

For use of this Detail X1971.dgn, see Design Memo at http://www.azdot.gov/highways/RdwyEng/RoadwayDesign/design_memos/Index.asp

NO.	DESCRIPTION OF REVISIONS	DATE
1	MINOR GRAPHICAL REVISIONS	7/05
2	REVISED NOTE TO DESIGNER	10/06
3		
4		

Date: 10/30/06

F.H.W.A. REGION	STATE	PROJECT NO.	SHEET NO.	TOTAL SHEETS	RECORD DRAWING
9	ARIZ.				

GENERAL NOTES

- The size, slope and type of end section, whether parallel or cross drainage, shall be shown on the plans.
 - A longitudinal bar is required for cross-drainage end sections when the span (W) is greater than 30". Additional longitudinal bars shall be required if spacing exceeds 30" on larger end sections.
 - Safety and longitudinal bars are not required on 30" and smaller cross-drainage end sections.
- - Top of Sloped End Section
 - - These Sizes Are Not Normally Used for Culverts by ADOT
 - ▲ - Headwalls Are Normally Required for Pipe Sizes 48" and Larger

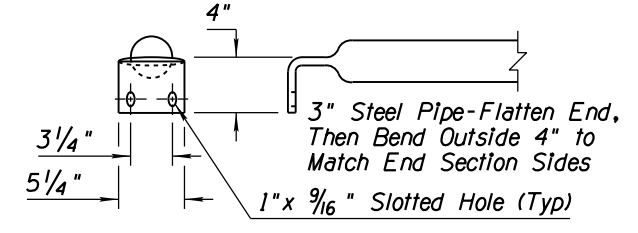
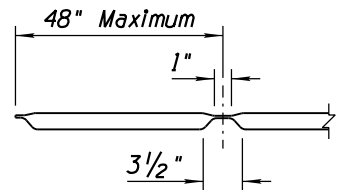
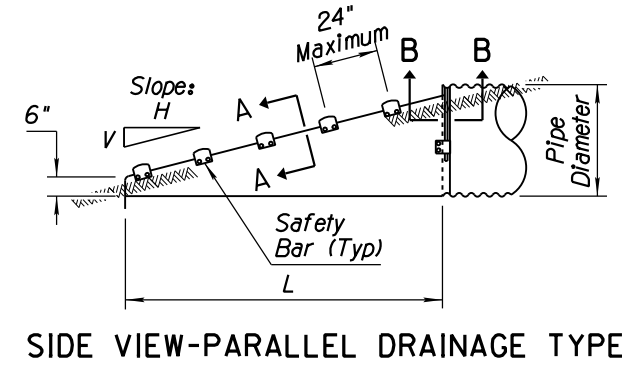
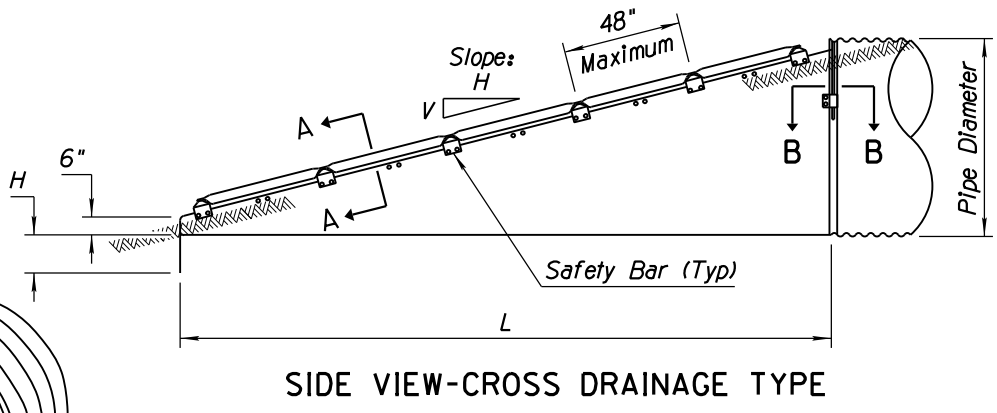
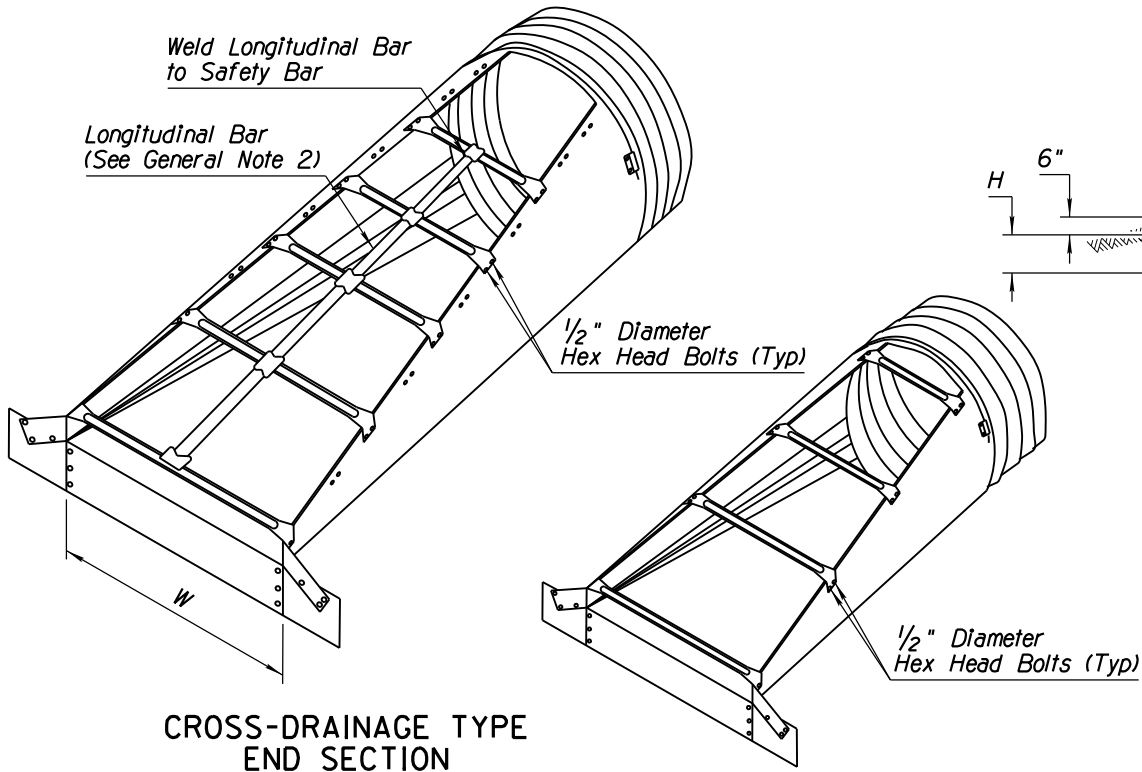

Pipe Diameter (In)	Minimum Thickness		Dimensions (In)				L Dimensions					
	In	Gauge	A	H	W	Overall Width	Slope H:V	Length (In)	Slope H:V	Length (In)	Slope H:V	Length (In)
15 ■	.064	16	8	6	21	37	4:1	20	6:1	30	10:1 ▲	70
18 ■	.064	16	8	6	24	40	4:1	32	6:1	48	10:1 ▲	100
21 ■	.064	16	8	6	27	43	4:1	44	6:1	66	10:1 ▲	130
24 ■	.064	16	8	6	30	46	4:1	56	6:1	84	10:1 ▲	160
30 ■	.109	12	12	9	36	60	4:1	80	6:1	120	10:1 ▲	220
36 ■	.109	12	12	9	42	66	4:1	104	6:1	156	10:1 ▲	280
42 ■	.109	12	16	12	48	80	4:1	128	6:1	192	-	-
48 ▲	.109	12	16	12	54	86	4:1	152	6:1	228	-	-
54 ▲	.109	12	16	12	60	92	4:1	176	6:1	264	-	-
60 ▲	.109	12	16	12	66	98	4:1	200	6:1	300	-	-

■ Minimum Thickness For All 10:1 Slope End Sections Is 12 Gauge

Equivalent Diameter (In)	(Inches)		Dimensions (In)				L Dimensions							
	Span	Rise	In	Gauge	A	H	W	Overall Width	Slope H:V	Length (In)	Slope H:V	Length (In)	Slope H:V	Length (In)
18 ■	21	15	.064	16	8	6	27	43	4:1	20	6:1	30	10:1 ▲	70
21 ■	24	18	.064	16	8	6	30	46	4:1	32	6:1	48	10:1 ▲	100
24 ■	28	20	.064	16	8	6	34	50	4:1	40	6:1	60	10:1 ▲	120
30 ■	35	24	.079	14	12	9	41	65	4:1	56	6:1	84	10:1 ▲	160
36 ■	42	29	.109	12	12	9	48	72	4:1	76	6:1	114	10:1 ▲	210
42 ■	49	33	.109	12	16	12	55	87	4:1	92	6:1	138	-	-
48 ▲	57	38	.109	12	16	12	63	95	4:1	112	6:1	168	-	-
54 ▲	64	43	.109	12	16	12	70	102	4:1	132	6:1	198	-	-
60 ▲	71	47	.109	12	16	12	77	109	4:1	149	6:1	222	-	-
72 ▲	83	57	.109	12	16	12	89	121	4:1	188	6:1	282	-	-

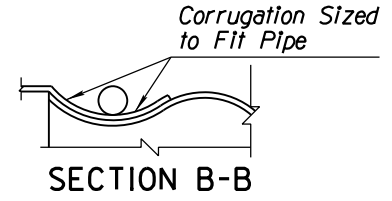
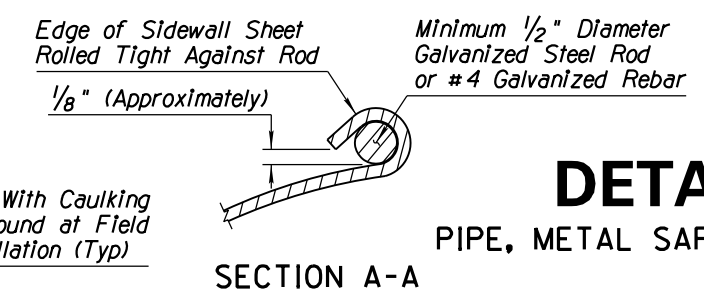
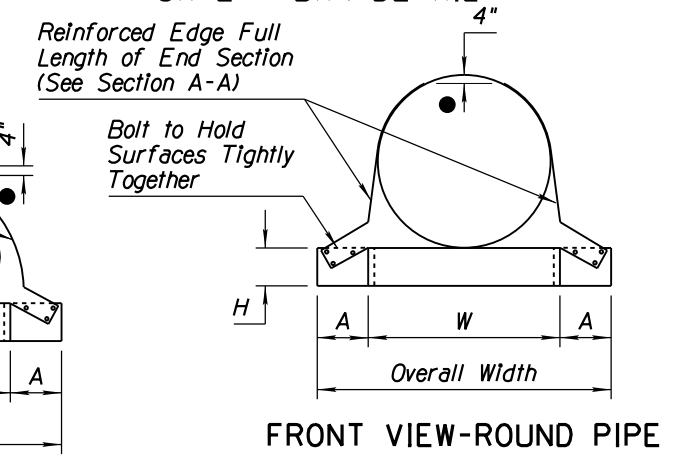
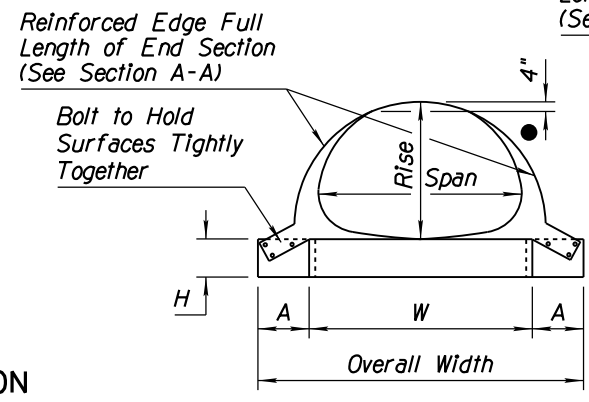
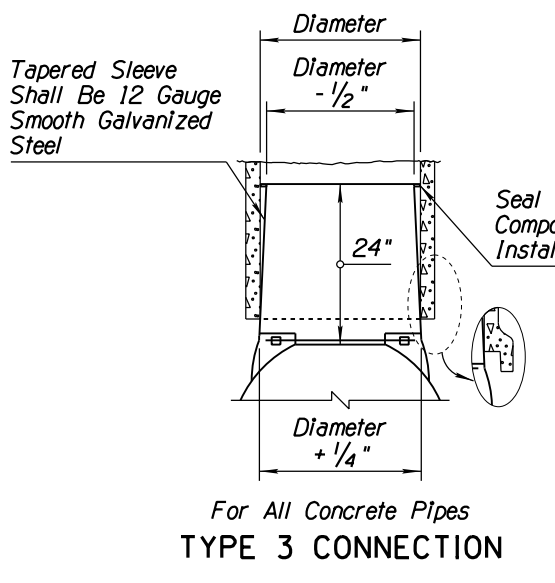
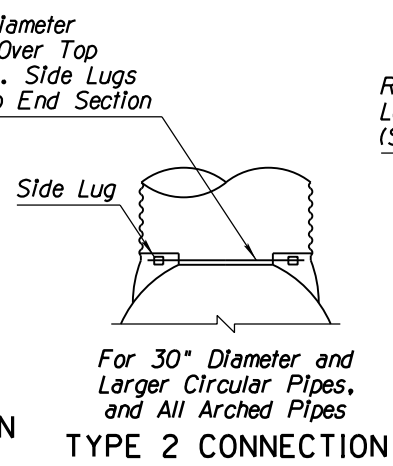
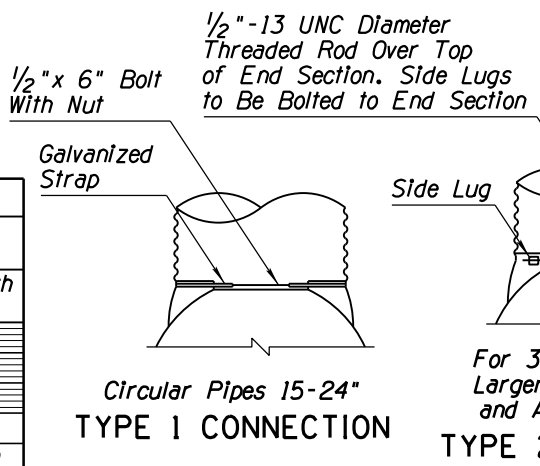

DETAIL

PIPE, METAL SAFETY END SECTION

DESIGN APPROVED	Kenneth R. Cooper	ARIZONA DEPARTMENT OF TRANSPORTATION INFRASTRUCTURE DELIVERY AND OPERATIONS DIVISION ROADWAY GROUP PLANS DETAIL
APPROVED FOR DISTRIBUTION	J. C. Cooper	
ROUTE	LOCATION	SHEET OF
TRACS NO.		OF