

## CHANGE LETTER

POLICY AND PROCEDURE DIRECTIVES MANUAL	CHANGE LETTER NO. 17
SUBJECT:  Title Page; Table of Contents; Policy and Procedure Directive No. 24.	EFFECTIVE DATE:  August 30, 2013

### SUMMARY:

NOTE: Unless otherwise specified, changes issued under this Change Letter are effective for projects with a bid opening date on or after August 30, 2013. Retain items removed from the Materials Policy and Procedure Directives Manual under this change letter for use as necessary on projects with a bid opening date prior to August 30, 2013.

1. TITLE PAGE - The Title Page has been revised to show the latest Change Letter number and revision date. Please replace the existing Title Page with the attached.
2. TABLE OF CONTENTS - The Table of Contents has been revised to reflect the changes made in this Change Letter. Please replace the existing Table of Contents with the attached.
3. The following new Policy and Procedure Directive is issued by this Change Letter.

P.P.D. No. 24 - "REQUIREMENTS FOR THE APPROVAL OF  
MECHANICALLY STABILIZED EARTH (MSE)  
WALL SYSTEMS"

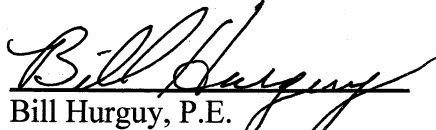
  
Bill Hurguy, P.E.  
Assistant State Engineer  
Materials Group

Attachment



**MATERIALS  
POLICY AND PROCEDURE  
DIRECTIVES MANUAL**



**PREPARED BY:  
ARIZONA DEPARTMENT OF TRANSPORTATION  
INTERMODAL TRANSPORTATION DIVISION  
MATERIALS GROUP**

**REVISED TO CHANGE LETTER NO. 17  
(August 30, 2013)**



**MATERIALS**  
**POLICY AND PROCEDURE**  
**DIRECTIVES MANUAL**

**TABLE OF CONTENTS**

<b><u>P. P. D.</u></b> <b><u>NO.</u></b>	<b><u>EFFECTIVE</u></b> <b><u>DATE</u></b>	<b><u>SUBJECT</u></b>
----	02/27/09	Introduction
1	02/27/09	Sampling, Testing, and Acceptance of Reinforcing Bars
2	02/27/09	Certification and Acceptance of Chemical and Air-Entraining Admixtures for Portland Cement Concrete
3a	04/14/10	Curing Compounds
4	02/27/09	Asphaltic Concrete Mix Design Proposals and Submittals
5a	04/14/10	Evaluation of Concrete Aggregate Sources
6	02/27/09	Provisional Seal Coat
7	02/27/09	Inspection of Concrete Batch Plants and Concrete Mixer Trucks
8	02/27/09	Sampling, Testing, and Acceptance of Emulsified Bituminous Materials
9	02/27/09	Guidelines for Inspection and Acceptance of Timber Guardrail Posts and Blocks
10	02/27/09	End Product Asphaltic Concrete Acceptance Testing – Procedure for Determination of Statistical Outliers

<b><u>P. P. D. NO.</u></b>	<b><u>EFFECTIVE DATE</u></b>	<b><u>SUBJECT</u></b>
11	02/27/09	Approval of Laboratories to Perform Testing of Bearing Pads for the Department
12	02/27/09	Review of Test Results and Issuance of Test Reports
13a	04/14/10	Certification and Acceptance of Hydraulic Cements, Fly Ash, Natural Pozzolan, Silica Fume, and Lime
14	02/27/09	Testing and Certification of Bituminous Distributor Trucks
15a	04/19/13	Submittal and Approval of Portland Cement Concrete Mix Designs
16c	02/07/13	ADOT Radiation Safety Program
17	02/27/09	Acquisition, Disposal, and Use of ADOT Licensed Materials Sources and Stockpile Sites
18	02/27/09	Determining Sample Times and Locations for End Product Asphaltic Concrete
19	04/14/10	ADOT System for the Evaluation of Testing Laboratories
20a	04/19/13	Guidance on the use of Reclaimed Asphaltic Pavement (RAP) in Asphaltic Concrete
21	01/06/11	Sampling, Testing, and Acceptance of Glass Beads (Spheres) for Striping Materials
22	05/03/11	Qualification and Specification Requirements for the Manufacturing of Precast/Prestress Concrete Bridge Members
23	09/28/12	Requirements for the Use of Warm Mix Asphalt (WMA) Technologies in Asphaltic Concrete
24	08/30/13	Requirements for the Approval of Mechanically Stabilized Earth (MSE) Wall Systems

# POLICY AND PROCEDURE DIRECTIVE

TO: ALL MANUAL HOLDERS	PPD NO. 24
SUBJECT:  REQUIREMENTS FOR THE APPROVAL OF MECHANICALLY STABILIZED EARTH (MSE) WALL SYSTEMS	EFFECTIVE DATE:  August 30, 2013

## 1. GENERAL

1.1 This Policy and Procedure Directive outlines the process for approval of a Mechanically Stabilized Earth (MSE) wall system. These requirements are used in conjunction with the Arizona Department of Transportation (ADOT or Department) Specifications.

1.2 “Mechanically Stabilized Earth (MSE) Wall” is the term used for a retaining wall system consisting of multiple structural components with horizontal anchor elements connected to the back face of the wall and embedded in backfill material behind the wall such that the mass and friction of the backfill material on the anchor elements prevents the wall from failing.

1.3 The complexity of the design and the propriety of specific wall components generally preclude the opportunity to generate a unique wall system design for each specific project. The Department’s highway development process is significantly enhanced through the selection of a preapproved MSE wall system that may be readily adapted to a specific project.

## 2. MSE WALL SYSTEM APPROVAL

2.1 In order to be placed on the Department’s Approved Products List (APL) the MSE wall system shall be reviewed and evaluated by an Engineer, hereafter called the Reviewing Engineer, whose qualifications are acceptable to the Materials Group. The Reviewing Engineer shall produce an evaluation report acceptable to the Materials Group.

2.2 The Materials Group will make the final decision on the acceptability of the Reviewing Engineer and the acceptability of the evaluation report. Materials Group will present its recommendation to the Materials Product Evaluation Committee for addition of the MSE Wall System to the APL.

### **3. MSE WALL SYSTEMS APPROVAL PROCESS**

3.1 Any MSE wall manufacturer, supplier, vendor, or contractor, hereinafter referred to as the Wall Company, may request that the Department add its proprietary wall system to the APL as follows:

3.1.1 To be placed on the APL, the Wall Company must complete the application available on the internet from the ADOT Research Center through its Product Evaluation Program.

3.1.2 The ADOT Research Center will notify ADOT Materials Group, Geotechnical Design Section, of the receipt of the application.

3.1.2 The Materials Group will provide the Wall Company with an Approval Package that includes the criteria under which the wall system shall be evaluated.

3.1.3 The Wall Company shall complete the approval application and propose to the Materials Group that the evaluation be conducted by a Reviewing Engineer meeting the qualifications as listed in Section 4 below.

3.1.4 The Materials Group will advise the Wall Company as to the acceptability of the proposed Reviewing Engineer.

3.1.5 The Wall Company shall contract with the Reviewing Engineer to evaluate the wall system and produce a report in the format outlined in the Approval Package.

3.1.6 Upon completion of the evaluation, the Wall Company shall submit the Reviewing Engineer's evaluation report, without modification, to the Materials Group.

3.1.7 After receipt of the completed report, the Materials Group will review the report and either:

- (a) accept the report and recommend placement of the wall system on the APL by the Materials Product Evaluation Committee,
- (b) request additional information from the Wall Company,
- (c) accept the report with restrictions, and recommend placement of the wall system on the APL with the restrictions, or
- (d) reject the report.



3.2 With respect to the MSE wall review and evaluation, the Arizona Department of Transportation will have no contractual relationship with the Reviewing Engineer. Coordination of, and payment for, the evaluation by the Reviewing Engineer is the responsibility of the Wall Company. All submittals, reviews, analysis, evaluations, and reports performed by the Reviewing Engineer shall be at no cost to the Department.

#### **4. REVIEWING ENGINEER QUALIFICATIONS**

4.1 The Reviewing Engineer performing the MSE wall evaluation shall be a Professional Engineer Registered by the Arizona State Board of Technical Registration. The report submitted to Materials Group shall be sealed by the Reviewing Engineer.

4.1.1 The Wall Company shall submit the Reviewing Engineer's resume and satisfactory evidence that the Reviewing Engineer has, at a minimum, the following experience:

- (a) 10 years experience with the design and construction of MSE walls, and
- (b) authored at least two American Association of State Highway and Transportation Officials (AASHTO), American Society of Civil Engineers (ASCE), Federal highway Administration (FHWA), or National Highway Institute (NHI) publications relating to the design and construction of MSE walls, and
- (c) authored at least two AASHTO, ASCE, FHWA, or NHI publications relating to AASHTO Load Resistance Factor Design (LRFD) design of MSE walls.

4.2 Alternatively, the Wall Company may propose that the evaluation be conducted by the Highway Innovative Technology Center (HITEC) of ASCE. The HITEC Technical Evaluation Report shall include, or be appended with, two additional test cases as shown in the Approval Package. The HITEC Technical Evaluation Report and any appendix shall be sealed by a Professional Engineer registered by the Arizona State Board of Technical Registration.

4.3 Other than performing the wall evaluation, the Reviewing Engineer shall have no ownership relationship with the Wall Company, and has not been an employer or employee of the Wall Company at any time during the previous five years. Any conflict of interest between the Reviewing Engineer and the Wall Company may result in disapproval of the Reviewing Engineer, rejection of the evaluation report, or the removal of the wall system from the list.

## 5. MSE WALL LIST RENEWAL

5.1 Any wall system on the APL will expire:

- (a) five years from the date of placement on the list,
- (b) upon any changes in the Wall Company's materials or design specification, or
- (c) if there are revisions in the technology such that updates to the design or approval process are deemed by ADOT to be necessary.

5.2 Provided that there are no changes as described in Section 5.1 that would require a new evaluation, as determined by ADOT, the renewal of the wall system on the APL may be expedited by a written request from the Wall Company certifying that no changes have occurred.

## 6. MSE WALL SYSTEM PERFORMANCE

6.1 ADOT reserves the right to remove an MSE wall system from the APL at any time and at its sole discretion. The reasons for the removal may include, but are not limited to:

- (a) wall failure, as determined by ADOT, on any public or private project;
- (b) non-response by the Wall Company, the Reviewing Engineer, or the contractor to an ADOT request;
- (c) substandard performance; lack of proper quality control; or,
- (d) improper response to correct construction defects.

6.2 Placement of a wall system on the Approved Products List does not constitute a commitment or agreement by ADOT to use the system on any highway construction project.

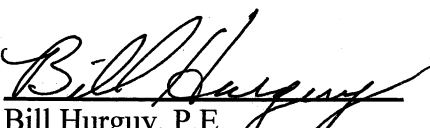
  
Bill Hurguy, P.E.  
Assistant State Engineer  
Materials Group



**ARIZONA DEPARTMENT OF TRANSPORTATION \* MATERIALS GROUP**

1221 NORTH 21ST AVENUE PHOENIX, ARIZONA 85009-3740 PHONE (602) 712 – 7231

# **SAMPLE APPROVAL PACKAGE**

## **REQUIREMENTS FOR THE APPROVAL OF MECHANICALLY STABILIZED EARTH (MSE) WALL SYSTEMS**

<b>Item</b>	<b>Page</b>	<b>Content</b>
A	2 - 4	Submittal Requirements for Approval of MSE Wall Systems
B	5 - 6	MSE Wall System Approval Application and Proposed Reviewing Engineer.
C	7 - 15	Reviewing Engineer's Report Format
D	16 - 19	Test Case Problems to be Included in the Reviewing Engineer's Report

# **ITEM A**

## **Submittal Requirements for Approval of MSE Wall Systems**

### **1. GENERAL**

1.1 This Approval Package outlines the process for approval of a Mechanically Stabilized Earth (MSE) wall system and placement of the wall system on the ADOT Approved Products List (APL).

1.2 MSE wall systems must meet the requirements of the current ADOT specifications or Special Provisions.

### **2. MSE WALL SYSTEM APPROVAL**

2.1 In order to be placed on the APL, the MSE wall system shall be reviewed and evaluated by an Engineer, hereafter called the Reviewing Engineer, whose qualifications are acceptable to the Materials Group. The Reviewing Engineer shall produce an evaluation report acceptable to the Materials Group.

2.2 The Materials Group will make the final decision on the acceptability of the Reviewing Engineer and the acceptability of the evaluation report. Materials Group will present its recommendation to the Materials Product Evaluation Committee for addition of the MSE Wall System to the APL.

### **3. MSE WALL SYSTEMS APPROVAL PROCESS**

3.1 Any MSE wall manufacturer, supplier, vendor, or contractor, hereinafter referred to as the Wall Company, may request that the Department add its propriety wall system to the APL as follows:

3.1.1 To be placed on the APL, the Wall Company must complete the application available on the internet from the ADOT Research Center through its Product Evaluation Program.

3.1.2 The ADOT Research Center will notify Materials Group, Geotechnical Design Section, of the receipt of the application.

3.1.2 The Materials Group will provide the Wall Company with a copy of this Approval Package which includes the criteria under which the wall system shall be evaluated.

3.1.3 The Wall Company shall complete the approval application and propose to the Materials Group that the evaluation be conducted by a Reviewing Engineer meeting the qualifications as listed in Section 4 below.

3.1.4 The Materials Group will advise the Wall Company as to the acceptability of the proposed Reviewing Engineer.

3.1.5 The Reviewing Engineer shall produce the evaluation report in the format outlined in Item C of this document.

3.1.6 Upon completion of the evaluation, the Wall Company shall submit the Reviewing Engineer's evaluation report, without modification, to the Materials Group.

3.1.7 After receipt of the completed report, the Materials Group will review the report and either:

- (a) accept the report and recommend placement of the wall system on the APL by the Materials Product Evaluation Committee,
- (b) request additional information from the Wall Company,
- (c) accept the report with restrictions, and recommend placement of the wall system on the APL with the restrictions, or
- (d) reject the report.

3.2 With respect to the MSE wall review and evaluation, the Arizona Department of Transportation will have no contractual relationship with the Reviewing Engineer. Coordination of, and payment for, the evaluation by the Reviewing Engineer is the responsibility of the Wall Company. All submittals, reviews, analysis, evaluations, and reports performed by the Reviewing Engineer shall be at no cost to the Department.

#### **4. REVIEWING ENGINEER QUALIFICATIONS**

4.1 The Reviewing Engineer performing the MSE wall evaluation shall be a Professional Engineer Registered by the Arizona State Board of Technical Registration. The report submitted to Materials Group shall be sealed by the Reviewing Engineer.

4.1.1 The Wall Company shall submit the Reviewing Engineer's resume and satisfactory evidence that the Reviewing Engineer has, at a minimum, the following experience:

- (a) 10 years experience with the design and construction of MSE walls, and
- (b) authored at least two American Association of State Highway and Transportation Officials (AASHTO), American Society of Civil Engineers ASCE, Federal Highway Administration (FHWA), or National Highway Institute (NHI) publications relating to the design and construction of MSE walls, and

- (c) authored at least two AASHTO, ASCE, FHWA, or NHI publications relating to AASHTO Load Resistance Factor Design (LRFD) design of MSE walls.

4.2 Alternatively, the Wall Company may propose that the evaluation be conducted by the Highway Innovative Technology Center (HITEC) of ASCE. The HITEC Technical Evaluation Report shall include, or be appended with, two additional test cases shown as Problems five and six below. The HITEC Technical Evaluation Report and any appendix shall be sealed by a Professional Engineer registered by the Arizona State Board of Technical Registration.

## **5. MSE WALL LIST RENEWAL**

5.1 Any wall system on the APL will expire:

- (a) five years from the date of placement on the list,
- (b) upon any changes in the Wall Company's materials or design specification, or
- (c) if there are revisions in the technology such that updates to the design or approval process are deemed by ADOT to be necessary.

5.2 Provided that there are no changes as described in Section 5.1 that would require a new evaluation, as determined by ADOT, the renewal of the wall system on the APL may be expedited by a written request from the Wall Company certifying that no changes have occurred.

## **6. MSE WALL SYSTEM PERFORMANCE**

6.1 ADOT reserves the right to remove an MSE wall system from the APL at any time and at its sole discretion. The reasons for the removal may include, but are not limited to:

- (a) wall failure, as determined by ADOT, on any public or private project;
- (b) non-response by the Wall Company, the Reviewing Engineer, or the contractor to an ADOT request;
- (c) substandard performance; lack of proper quality control; or,
- (d) improper response to correct construction defects.

6.2 Placement of a wall system on the Approved Products List does not constitute a commitment or agreement by ADOT to use the system on any highway construction project.

## ITEM B

### **MSE Wall System Approval Application and Proposed Reviewing Engineer Form**

Company / Firm Name	
Product Name	
Name and contact information of Authorized Representative who will serve as the contact person for the Wall Company through this approval process	Name: Address:  Phone #: Fax #: E-Mail:
Signature and Title of the Authorized Wall Company Representative	Signature: _____ Print Name: _____  Title: _____ Date: _____

**A. Ownership of Technology or Product (circle your answer)**

Yes No Are you the owner of the technology or product? If not, please describe the licensing or other contractual arrangement, which gives you the legal right to the technology or product being submitted to ADOT for approval.

**B. Patents (circle your answers)**

1. Yes No Do you agree to provide technical assistance (on-site or via telephone with needed supporting documentation and information) to ADOT throughout the approval process at no cost to ADOT?

2. Yes No Do you grant permission to ADOT to reproduce, in full or in part, any information supplied by you or the Reviewing Engineer in association with the Application, unless specifically excluded and clearly marked as not being authorized for reproduction? This permission also will apply to material with copyrights held by you.

3. Yes No Does the product involve proprietary technology?

4. Yes No Is the product patented, copyrighted, or otherwise protected?
5. If proprietary or patented technology is involved, please provide a summary description of the proprietary / protected features [attach additional sheet(s) if necessary]:

**C. Propose a Reviewing Engineer**

When proposing a Reviewing Engineer please include the following:

1. The name of the consultant firm that will evaluate the MSE wall, complete the test case problems, and produce the Report.
2. The name and registration number of the Arizona Registered Engineer employed by the consultant firm who will seal the Report.
3. The resume and list of qualifications of the Reviewing Engineer, showing specifically that the minimum qualifications as shown in Section 4 in Item A of this Approval Package have been met.

**D. Conflict of interest**

By signing the Approval Application the Wall Company certifies that there is no conflict of interest between itself and the Reviewing Engineer, and that the Reviewing Engineer has no ownership relationship with the Wall Company, and has not been an employer or employee of the Wall Company at any time during the previous five years.

Any conflict of interest between the Reviewing Engineer and the Wall Company may result in disapproval of the Reviewing Engineer, rejection of the evaluation report, or the removal of the wall system from the list.



## **ITEM C**

### **Reviewing Engineer's Report Format**

#### **INSTRUCTIONS**

##### **A. Evaluation by a Reviewing Engineer**

The Reviewing Engineer's Report shall include the required information in the following format.

Please respond to all items that apply to the system and its components.

Responses should be organized in the order shown and referenced to the given numbering system. Duplication of information is not necessary. The report should reference applicable sections where information has been provided in another section.

##### **B. Evaluation by the Highway Innovative Technology Center (HITEC) of the American Society of Civil Engineers**

The standard HITEC Evaluation will be accepted provided that the report is supplemented by the two additional test cases shown as PROBLEM 5 and PROBLEM 6 in Item D of this document, and the HITEC Report is sealed by the Engineer who produced the evaluation report and who is registered as a Professional Engineer with the Arizona State Board of Technical Registration.

## **TABLE OF CONTENTS**

- 1.0 System
  - 1.1 Description of System and Components
  - 1.2 History
  - 1.3 Arizona Applications
  - 1.4 System Warranties
  - 1.5 Designated Responsible Parties
  - 1.6 Insurance Coverage for Responsible Party
  
- 2.0 Design
  - 2.1 Summary of Design Parameters
  - 2.2 Design Responsibility
  - 2.3 Summary of Design Procedures
  - 2.4 Summary of Example Calculations
  - 2.5 Limitations
  
- 3.0 Materials
  - 3.1 Facing Unit – wet cast, steel reinforced panels
  - 3.2 Modular Block – dry-cast, unreinforced masonry units
  - 3.3 Metallic Soil Reinforcement
  - 3.4 Geosynthetic Soil Reinforcement
  - 3.5 Facing Connection Components
  - 3.6 Reinforced Wall Fill
  - 3.7 Leveling Pad
  - 3.8 Drainage Elements
  - 3.9 Coping
  - 3.10 Traffic Railing / Barrier
  - 3.11 Precast Connections to Appurtenances
  - 3.12 Other Materials
  - 3.13 Quality Control / Quality Assurance Systems
  
- 4.0 Details
  - 4.1 Standard Details
  - 4.2 Example Details
  
- 5.0 Construction
  - 5.1 Fabrication of Facing Units
  - 5.2 Field Construction Manual
  - 5.3 Construction Specifications
  - 5.4 Contractor or Subcontractor Prequalification Requirements
  - 5.5 Quality Control / Quality Assurance of Construction
  - 5.6 Construction / In-Service Structure Problems
  - 5.7 Maintenance
  - 5.8 Quality Control History

## 1.0 System

### 1.1 Description of System and Components

- a. Summarize what the system consists of, and what is not included.
- b. List each component of the system.
- c. List material requirements for each component.

### 1.2 History

- a. Summarize the history of development and application of the system.
- b. Summarize refinements made to the system, since inception.
- c. Summarize performance (with photos, where available) of constructed structures, including:
  - i. oldest
  - ii. highest
  - iii. projects experiencing maximum measured settlement (total and differential)
  - iv. measurements of lateral movement / tilt
  - v. demonstrated aesthetics
  - vi. project photos
  - vii. maintenance history
- d. Summarize any incidents of where the product or any component of the project for which an approval was revoked by a government agency during the past five years. List these products, if any, and describe the relationship between the rejected or revoked product and the product being evaluated in this report. Where applicable, include a description of any predecessor product.

### 1.3 Arizona Applications

- a. Summarize the history of application of the system in Arizona.
- b. Summarize the history of application of the system on ADOT projects.
- c. Summarize design issues specific to Arizona applications.
- d. Summarize construction issues specific to Arizona applications.
- e. Provide a list of non-ADOT users, including a contact person for each user with their telephone number and a summary of the project application.

### 1.4 System Warranties – provide a copy of any system warranties

### 1.5 Designated Responsible Parties – summarize responsibilities for:

- a. system performance
- b. material performance
- c. project-specific design

### 1.6 Insurance Coverage for Responsible Party – list insurance coverage types (e.g., professional liability, product liability, performance), limits, and basis (i.e., per occurrence, claims made) provided by each responsible party.

## 2.0 Design

2.1 Summary of Design Parameters – provide a summary of the following, and note applicable standard and / or test method used to quantify value:

- a. Ultimate strength of soil reinforcement element(s)
- b. Long-term allowable strength of soil reinforcement element(s)
- c. Direct shear interaction coefficient
- d. Normalized pullout resistance factors,  $F^*$  and  $\alpha$
- e. Galvanization thickness

2.2 Design Responsibility

- a. State designated responsible party for project-specific design.
- b. List professional liability insurance coverage limits and basis (i.e., per occurrence, claims made) provided by the design responsible party.
- c. Detail the system designer's Quality Control / Quality Assurance programs for project designs.
- d. List those items of a project design that you understand, or assume, are the responsibility of ADOT.

2.3 Summary of Design Procedures

- a. Summarize all deviations from the most current American Association of State Highway and Transportation Officials (AASHTO) LRFD Bridge Design Specifications, along with theoretical or empirical information which support such deviations.
- b. Summarize when and how compound / global stability are assessed.
- c. Summarize seismic design considerations.
- d. Detail design modification for tiered structures.
- e. Detail design modification for acute corners.
- f. Detail design to overcome obstructions (e.g., drainage structures, deep foundations, etc.) in reinforced zones.

2.4 Summary of Example Calculations

- a. Provide detailed calculations for the long-term allowable tensile strength of the soil reinforcement to facing unit connector(s). Note any deviation from the most current AASHTO LRFD Bridge Design Specifications.
- b. Provide detailed calculations for reinforcements in facing units, as applicable.

2.5 Limitations – list all design limitations, including seismic loading; environmental restraints; wall height; external loading; differential settlement; and others

**3.0 Materials** – Provide material specifications describing the material type, quality, certifications, lab and field testing, and acceptance and rejection criteria, along with support information (and where noted, a sample of the material) for each of the following material items. Include representative test results (lab and field) clearly referencing the date, source, and method of test, and where required, the method and detailed explanation of interpretation and extrapolation. Note the source of the supplied information, include a listing of facilities normally used for testing (e.g.,

in-house and independent). Clearly identify the materials listed below that do not apply to the product being submitted.

3.1 Facing Unit – wet-cast, steel reinforced panels

- a. standard dimensions and tolerances
- b. steel reinforcement details
- c. joint sizes and details
- d. concrete strength (minimum)
- e. wet cast concrete % air (range)
- f. freeze thaw durability
- g. bearing pads (joints)
- h. spacers (pins, etc.)
- i. joint filter requirements: geotextile or graded granular
- j. aesthetic choices (texture, relief, color, graffiti treatment)
- k. other facing materials

3.2 Modular Block – dry-cast, unreinforced masonry units

- a. standard dimensions and tolerances
- b. thickness at front face
- c. joint sizes and details
- d. concrete strength (minimum)
- e. dry cast concrete density (minimum or range)
- f. moisture absorption (percent and by weight)
- g. salt scaling
- h. freeze thaw durability
- i. facing unit to facing unit shear resistance
- j. bearing pads
- k. spacers, pins, etc.
- l. joint filler requirements: geotextile or graded granular
- m. maximum recommended vertical joint opening
- n. aesthetic choices (textures, relief, color, graffiti treatment)
- o. other facing materials

3.3 Metallic Soil Reinforcement

- a. manufacturing sizes, tolerances and lengths
- b. ultimate and yield strength of steel
- c. minimum galvanization thickness for 75 year design life
- d. sacrificial steel thicknesses for 75 and 100 year design life
- e. pullout interaction coefficients for range of backfill

3.4 Geosynthetic Soil Reinforcement

- a. polymer resin and grade
  - i. High Density Poly Ethylene (HDPE): resin type, class, grade, and category
  - ii. Polypropylene (PP): resin type, class, grade, and category

- iii. Polyester (PET): minimum intrinsic viscosity correlated to number average molecular weight and maximum carboxyl end groups
    - iv. mass per unit area
    - v. post-consumer recycled material, if any
  - b. ultimate strength minimum average roll value and coefficient of variation for ultimate strength
  - c. QC strength (e.g., single rib, grab or strip) minimum average roll value
  - d. creep reduction factors for 75 and 100 year design life, including effect of temperature (20 °C to 40 °C)
  - e. durability reduction factor (chemical, hydrolysis, oxidative) for 75 and 100 year design life
  - f. additional durability reduction factor for high biologically active environments
  - g. installation damage reduction factor for range of backfill (e.g., sand, sandy gravel, gravel, coarse gravel) for allowable gradation criteria
  - h. junction strength (geogrids) for quality control
  - i. seam strength
  - j. pullout interaction coefficients for range of backfills
  - k. embedment scale factor
  - l. coatings (type and amount)
  - m. UV inhibitors, coatings, etc.
  - n. UV resistance

### 3.5 Facing Connection Components

- a. mode (e.g., structural, frictional, or combined)
- b. connection strength as a % of reinforcement strength at various confining pressures for each reinforcement product and connection type submitted
- c. composition of devices, dimensions, tolerances
- d. full scale connection test method / results

### 3.6 Reinforced Wall Fill

- a. soil classification
- b. gradation range
- c. unit weight (design and representative measured)
- d. friction angle (design and representative measured)

### 3.7 Leveling Pad

- a. cast-in-place
- b. precast
- c. granular

### 3.8 Drainage Elements

- a. weep holes
- b. surface drainage components
- c. subsurface drainage components

### 3.9 Coping

- a. precast
- b. precast attachment method / details
- c. cast-in-place
- d. precast and cast-in-place combination

### 3.10 Traffic Railing / Barrier

- a. precast
- b. cast-in-place
- c. precast and cast-in-place combination

### 3.11 Precast Connections to Appurtenances

### 3.12 Other Materials

- a. corner elements
- b. slip-joint elements

### 3.13 Quality Control / Quality Assurance Systems

- a. material suppliers
  - i. metallic reinforcement
  - ii. polymeric reinforcement
  - iii. concrete products
  - iv. wall fill
- b. fabricator(s)
- c. test facilities (internal and external)

## 4.0 Details

### 4.1 Standard Details – provide detailed drawings of the following standard details (in hard copy and also in electronic copy in Microstation J format):

- a. leveling pad
- b. face unit steel reinforcement and connection inserts
- c. erection details of face units including temporary bracing, batter, joint spacing, etc
- d. connection
- e. top of wall coping
- f. top of wall traffic barrier
- g. bottom of wall traffic barrier
- h. top of wall membrane protection for areas where deicing salts are used
- i. construction of cast-in-place traffic barriers
- j. joint drainage details
- k. weep holes
- l. subsurface drainage
- m. subsurface drain outlets
- n. overhead light standard incorporated into the wall facing
- o. slip joint detail
- p. end of wall

- q. connection to appurtenances (e.g., box inlets and large obstructions)
- r. fill placement procedures at reinforcement elevation
- s. architectural face finish options

4.2 Example Details – provide detailed drawings illustrating typical examples of the following details:

- a. stepping of leveling pad with existing and final grades
- b. stepping of top of wall with final grade
- c. placement of reinforcement around steel piles
- d. placement of reinforcement around concrete shafts
- e. placement of reinforcement around drop inlet structures
- f. placement of reinforcement around pipe penetrations

**5.0 Construction** – Provide the following information related to construction of the system:

5.1 Fabrication of Facing Units

- a. curing times
- b. form removal
- c. concrete surface finish requirements

5.2 Field Construction Manual – provide a documented field construction manual describing in detail, with illustrations as necessary, the step-by-step construction sequence, including requirements for:

- a. foundation preparation
- b. special tools required
- c. leveling pad
- d. facing erection
- e. facing batter for alignment
- f. steps to maintain horizontal and vertical alignment
- g. retained and backfill placement / compaction
- h. erosion mitigation
- i. all equipment requirements

5.3 Construction Specifications – include sample construction specifications that address:

- a. materials requirements
- b. field sampling, testing, and acceptance / rejection requirements
- c. installation requirements
- d. maintenance requirements
- e. aesthetics compliance, including texture, color, graffiti treatment, and durability of aesthetic features

5.4 Contractor or Subcontractor Prequalification Requirements – list any contractor or subcontractor prequalifications



5.5 Quality Control / Quality Assurance of Construction – detail the quality control and quality assurance measurements required during construction to assure consistency in meeting performance requirements, and responsible parties for each

5.6 Construction / In-Service Structure Problems – provide case histories of structures where problems have been encountered, including an explanation of the problems and methods of repair

5.7 Maintenance – provide a listing of maintenance requirements to maintain performance and repair damage. If available, provide a maintenance manual

5.8 Quality Control History – provide the history for the system and material quality along with improvements that have been made based on the experience with the system

## **ITEM D**

### **Test Case Problems to be Included in the Reviewing Engineer's Report**

All references made to AASHTO (2012) herein shall mean "AASHTO LRFD Bridge Design Specifications", 6<sup>th</sup> Edition, including latest Interims.

PROBLEM 1:

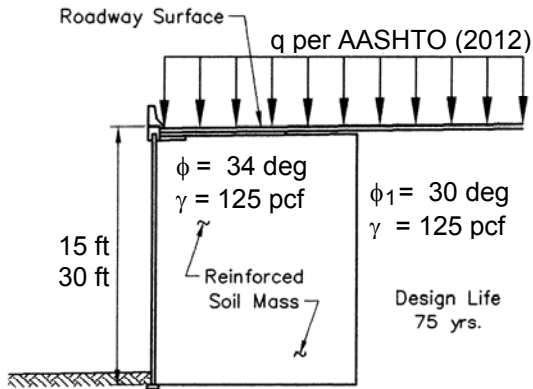

PROBLEM 2:

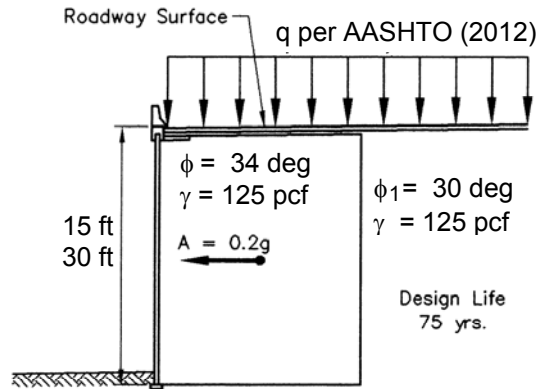

Note: For Problems 1 and 2, incorporate the presence of barriers in the design in terms of impact loading. Use ADOT 42-inch barrier detail as shown in ADOT Standard Drawing No. SD-1.02. Use Test Level-5 (TL-5) loading as per Table A13.2-1 in AASHTO (2012).

PROBLEM 3:

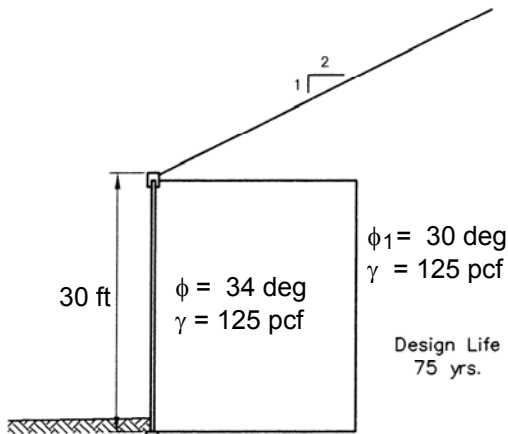

PROBLEM 4:

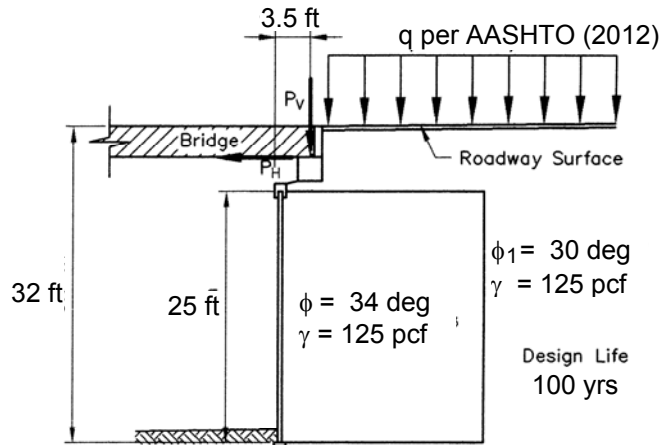

$P_V = 10.6 \text{ k/ft (Dead); } 5.7 \text{ k/ft (Live)}$   
 $P_H = 1 \text{ k/ft}$

Assume following conditions:

1. Setback of edge of the footing from the back of the facing units is 6-inches
2. Footing width = 10.75 ft
3. Footing to be resting on top of MSE mass, i.e., 25-ft above the top of leveling pad.
4. Height of backwall (incl footing thickness) = 7-ft
5. No approach slab, i.e., consider full live load

**PROBLEM 5:**

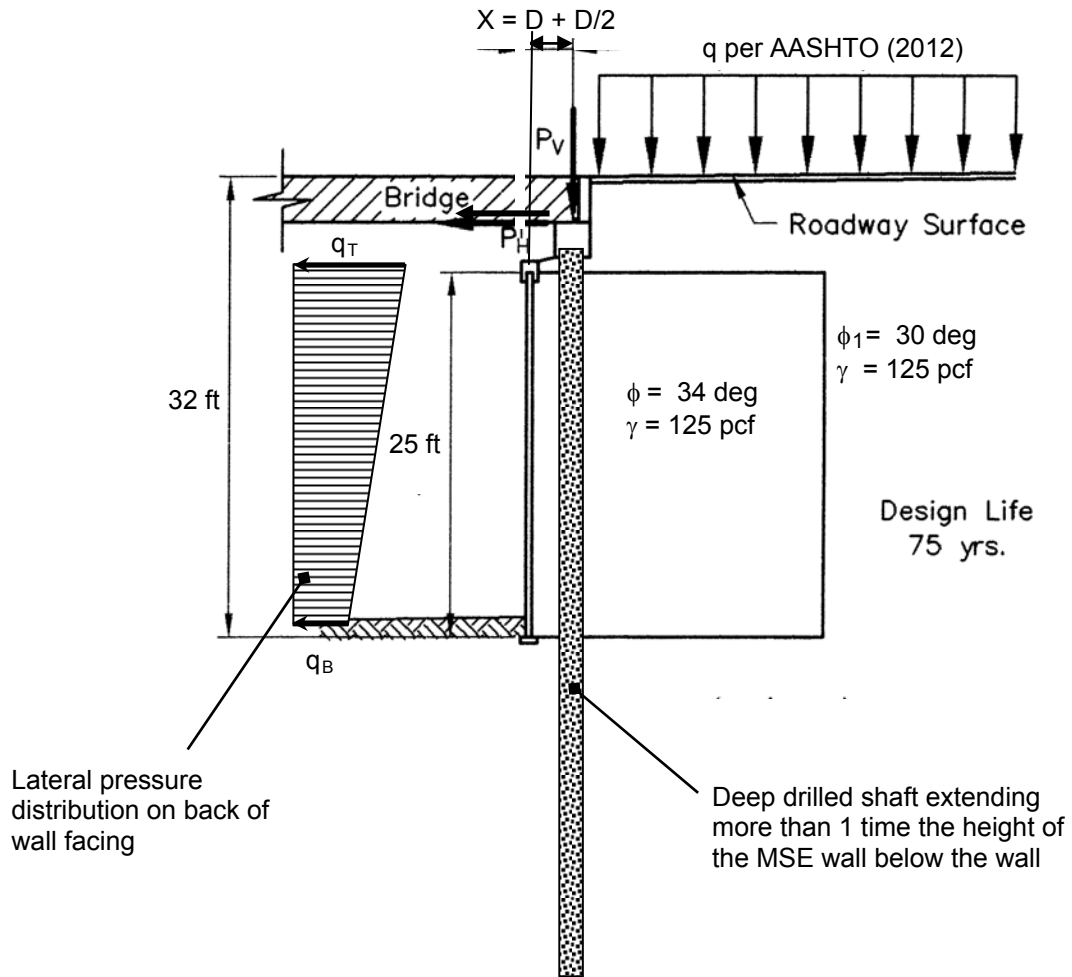

$q_T = 200$  psf ;  $q_B = 75$  psf

Note:  $X$  is measured from the back-face of the facing unit to the center of the drilled shaft.

**PROBLEM 6:**

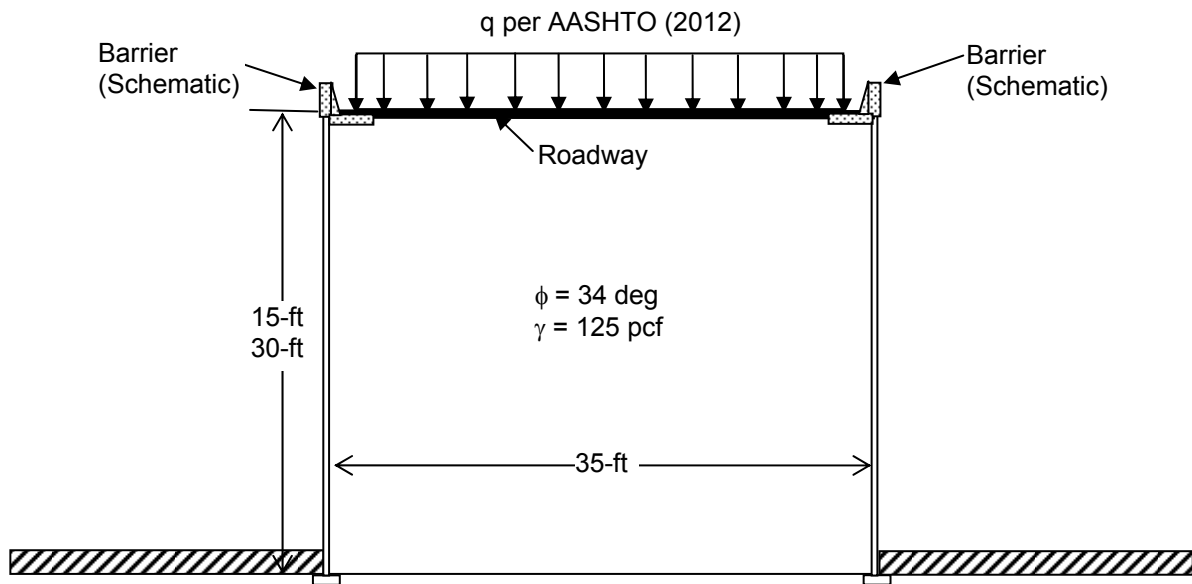

Note: Incorporate the presence of barriers in the design in terms of impact loading. Use ADOT 42-inch barrier detail as shown in ADOT Standard Drawing No. SD-1.02. Use Test Level-5 (TL-5) loading as per Table A13.2-1 in AASHTO (2012).