

**PARTICLE SHAPE AND TEXTURE OF
FINE AGGREGATE USING
UNCOMPACTED VOID CONTENT**

(A Modification of AASHTO T 304)

1. SCOPE

- 1.1 This method covers the determination of the "Uncompacted Void Content" of a fine aggregate for use as a measure of its angularity and texture.
- 1.2 This test method may involve hazardous material, operations, or equipment. This test method does not purport to address all of the safety concerns associated with its use. It is the responsibility of whoever uses this test method to consult and establish appropriate safety and health practices and determine the applicability of regulatory limitations prior to use.
- 1.3 This procedure provides a numerical result in terms of percent void content, determined under standardized conditions, which correlates with the particle shape and texture properties of a fine aggregate. An increase in void content indicates greater angularity and rougher texture. Lower void content results are associated with more rounded smooth particles.
- 1.4 See Appendix A1 of the Materials Testing Manual for information regarding the procedure to be used for rounding numbers to the required degree of accuracy.

2. APPARATUS

- 2.1 Requirements for the frequency of equipment calibration and verification are found in Appendix A3 of the Materials Testing Manual.
- 2.2 A funnel having a volume of at least 200 cm³, or being equipped with a supplemental container to provide the required volume. (See Figure 1)
- 2.3 Funnel Stand - A support capable of holding the funnel firmly in position with its axis vertically in line with the axis of the measure, and the funnel opening 4.5 ± 0.1 inches above the top of the cylinder. A suitable arrangement is shown in Figure 1.

- 2.4 Measure - A cylinder of approximately 100 cm³ capacity. (See Figure 2)
- 2.5 A flat metal or plastic pan of sufficient size for containing the funnel stand, and preventing loss of material that overflows the measure during filling and strike off. The pan shall not be warped so as to prevent rocking of the apparatus during testing.
- 2.6 A straight metal spatula at least 1" greater than the diameter of the measure and at least 1/2" wide. The end shall be cut at a right angle to the edges. The straight edge of the spatula is used to strike off the fine aggregate. (See Figure 3)
- 2.7 A balance or scale capable of measuring the maximum weight to be determined and conforming to the requirements of AASHTO M 231, except the readability and sensitivity of any balance or scale utilized shall be at least 0.1 gram.
- 2.8 Sieves of sizes No. 8, No. 16, No. 30, No. 50 and No. 100, conforming to the requirements of ASTM E11.

3. CALIBRATION OF MEASURE

- 3.1 Determine and record the weight of the dry, empty measure and a flat, glass plate slightly larger than it's diameter. Fill the measure with water at a temperature of 77 ± 1 °F. Place the glass plate on the measure, being sure that no air bubbles remain. It may be necessary to lightly coat the top edge of the measure with grease prior to determining the weight of the empty measure and glass plate. Dry the outer surfaces of the measure and determine and record the combined weight of measure, glass plate, and water.
- 3.2 Determine and record the volume of the measure to the nearest 0.01 cm³ by the following calculation:

$$V = \frac{w}{0.997}$$

Where: V = volume of cylinder in cm³
w = net weight of water in grams
0.997 g/cm³ = the density of water at 77 ± 1 °F

4. SAMPLE PREPARATION

4.1 Obtain a sample of Minus No. 8 Material of sufficient size (but not less than 500 grams) to yield the quantities required in Subsection 4.3 below. The sample used for this test may either be virgin aggregate, or aggregate obtained from the extraction of a bituminous mixture.

4.2 Utilizing either a No. 100 or a No. 200 sieve, wash the sample in accordance with either Section 6 or 7 of Arizona Test Method 201. Dry the material to constant weight and sieve into size fractions as indicated in Subsection 4.3 below. Maintain the material in a dry condition in separate containers for each of the sizes specified. The sieving is to be accomplished in accordance with Arizona Test Method 201.

Note: Processing additional material may be required.

4.3 Weigh out and combine the following quantities of dry fine aggregate from each of the sizes below:

PASS	RETAINED	WEIGHT IN GRAMS	ACCUM. WEIGHT
# 8	# 16	44 ± 0.2	44 ± 0.2
# 16	# 30	57 ± 0.2	101 ± 0.4
# 30	# 50	72 ± 0.2	173 ± 0.6
# 50	# 100	17 ± 0.2	190 ± 0.8

5. PROCEDURE

5.1 If the fine aggregate has become moist, dry to constant weight and cool to room temperature.

5.2 Record the weight of the empty measure to the nearest 0.1 gram, place the funnel and measure in the funnel stand, and place the assembly in the pan described in Subsection 2.5.

5.3 Mix the test sample until it appears homogeneous. Using a finger to block the opening, pour the test sample into the funnel. Lightly level the top of the material using the end of the spatula. Remove the finger and allow the sample to fall freely into the measure.

5.4 After the funnel empties, remove excess fine aggregate from the measure by a single pass of the spatula with the edge of the blade vertical and in light contact with the top of the measure. Until this operation is complete, exercise care to avoid vibration or disturbance that could cause compaction of the fine aggregate in the measure. After strike-off, tap the measure lightly to compact the sample to make it easier to transfer the measure to the balance without spilling any of the sample. Brush adhering material from the outside of the measure and determine and record the weight of the measure and contents to the nearest 0.1 gram. (See Figure 3)

Note: The intent of this process is to allow the sample to flow freely into the measure without any vibrations or disturbance of the cylinder until the operation is complete. The cylinder may be held during strikeoff as long as there is no vibration or disturbance from the strike off process.

5.5 Collect all of the fine aggregate from the pan and measure, and repeat the procedure again.

5.6 For each determination, record the net weight of the fine aggregate in the measure. If the two net weights differ by 0.5 gram or less, average the two weights and record to the nearest 0.1 gram as the "average net weight of fine aggregate in measure", (W). If the two weights differ by more than 0.5 gram, the procedure shall be repeated until any two results are achieved which differ by 0.5 gram or less. The average of these two results is recorded to the nearest 0.1 gram as the "average net weight of fine aggregate in measure", (W).

6. CALCULATION

- 6.1 Determine and record the "Uncompacted Void Content" (U), to the nearest 0.1% by the following calculation:

$$U = \frac{V - (W/G)}{V} \times 100$$

Where: U = Uncompacted Void Content, percent.
V = volume of measure in cm³.
W = average net weight of fine aggregate in measure.
G = bulk oven dry specific gravity of fine aggregate, measured in accordance with Arizona Test Method 211, "Specific Gravity and Absorption of Fine Aggregate".

- 6.2 For most aggregate sources the fine aggregate specific gravity does not vary much from sample to sample. It is intended that the value used in the above calculation be from a routine specific gravity test which is representative of the fine aggregate. A difference in specific gravity of 0.05 will change the calculated "Uncompacted Void Content" about one percent.

7. REPORT

- 7.1 The "Uncompacted Void Content" (U), to the nearest 0.1%.
- 7.2 The bulk oven dry specific gravity of the fine aggregate (G), to the nearest 0.001.

FUNNEL, FUNNEL STAND, AND MEASURE

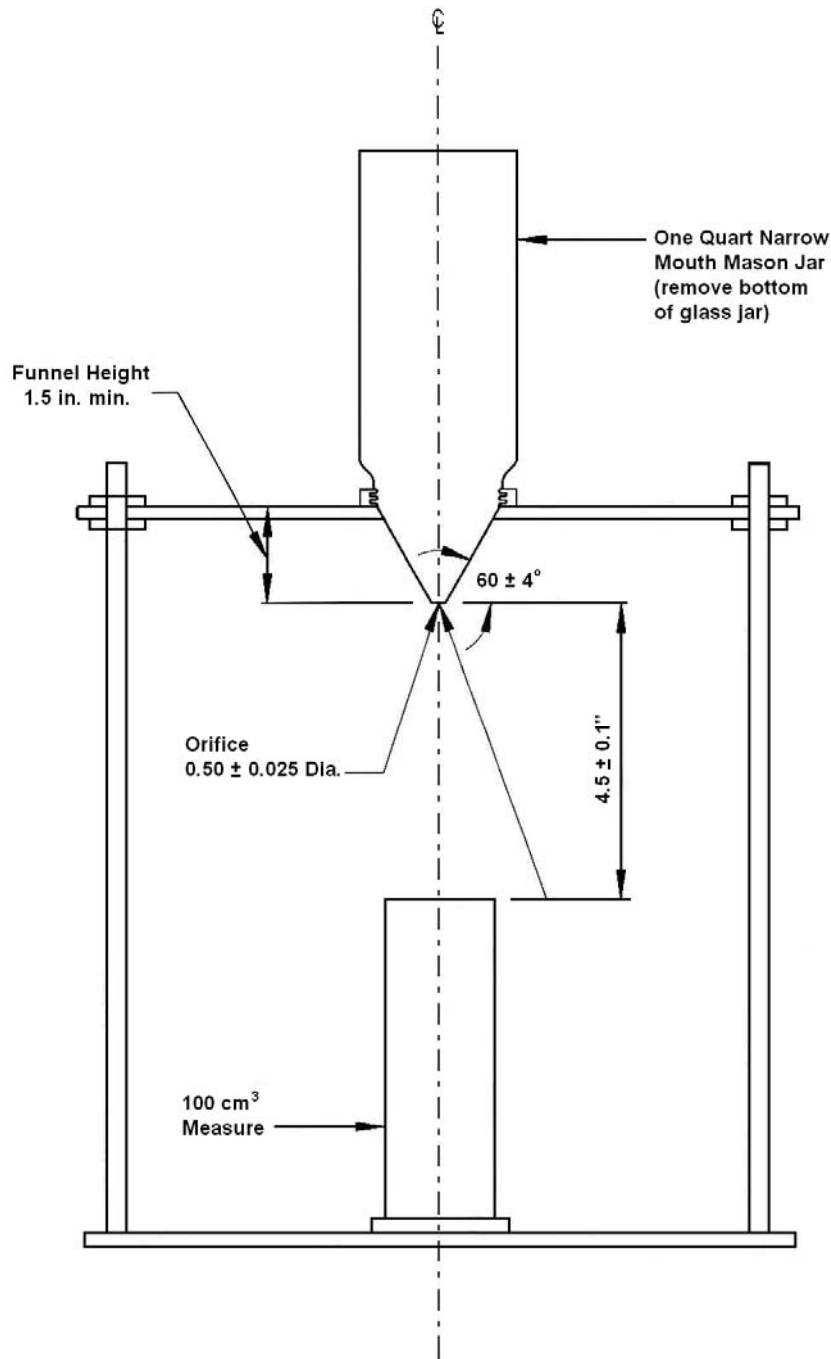

Section Through Center of Apparatus

FIGURE 1

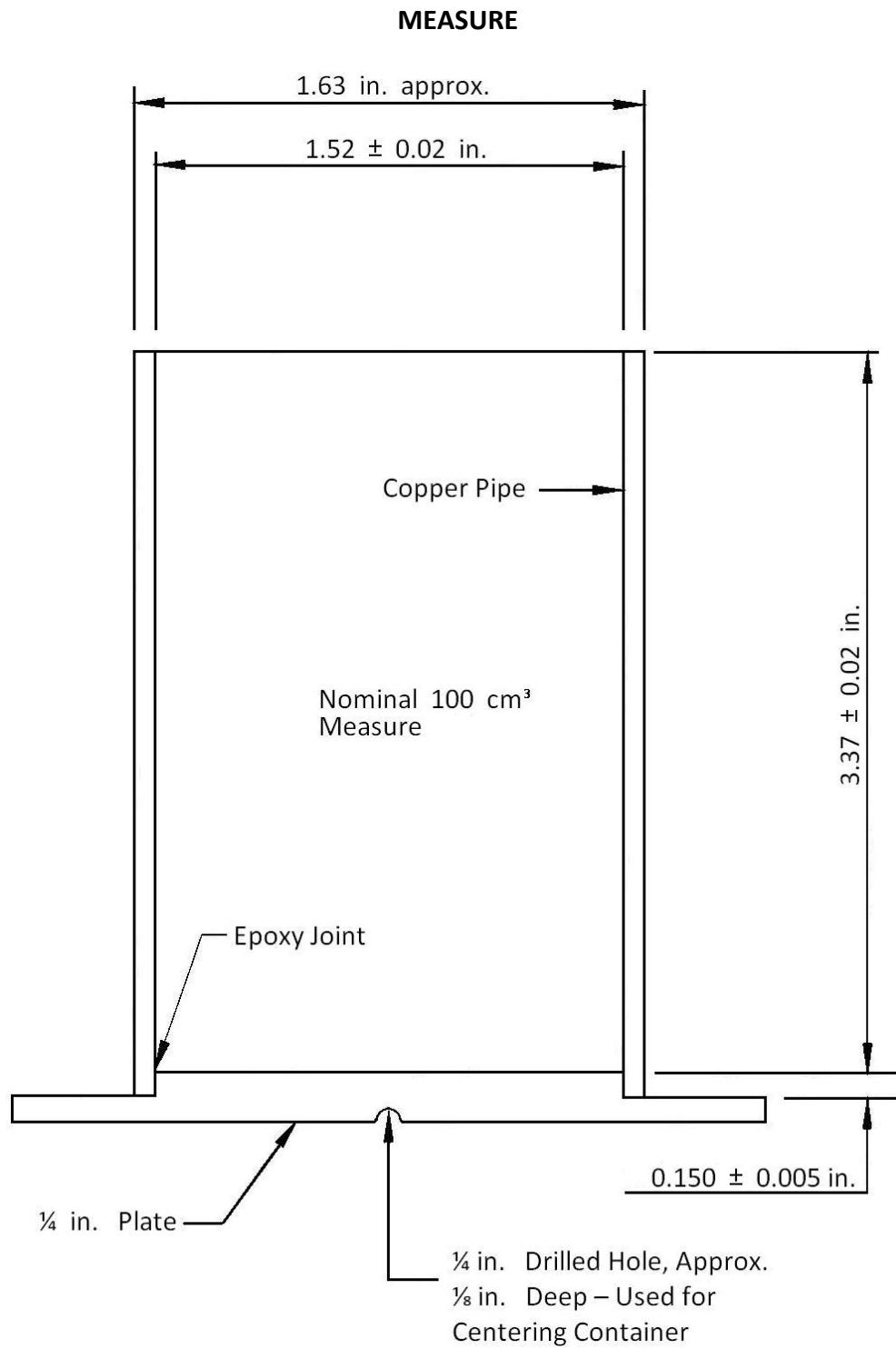
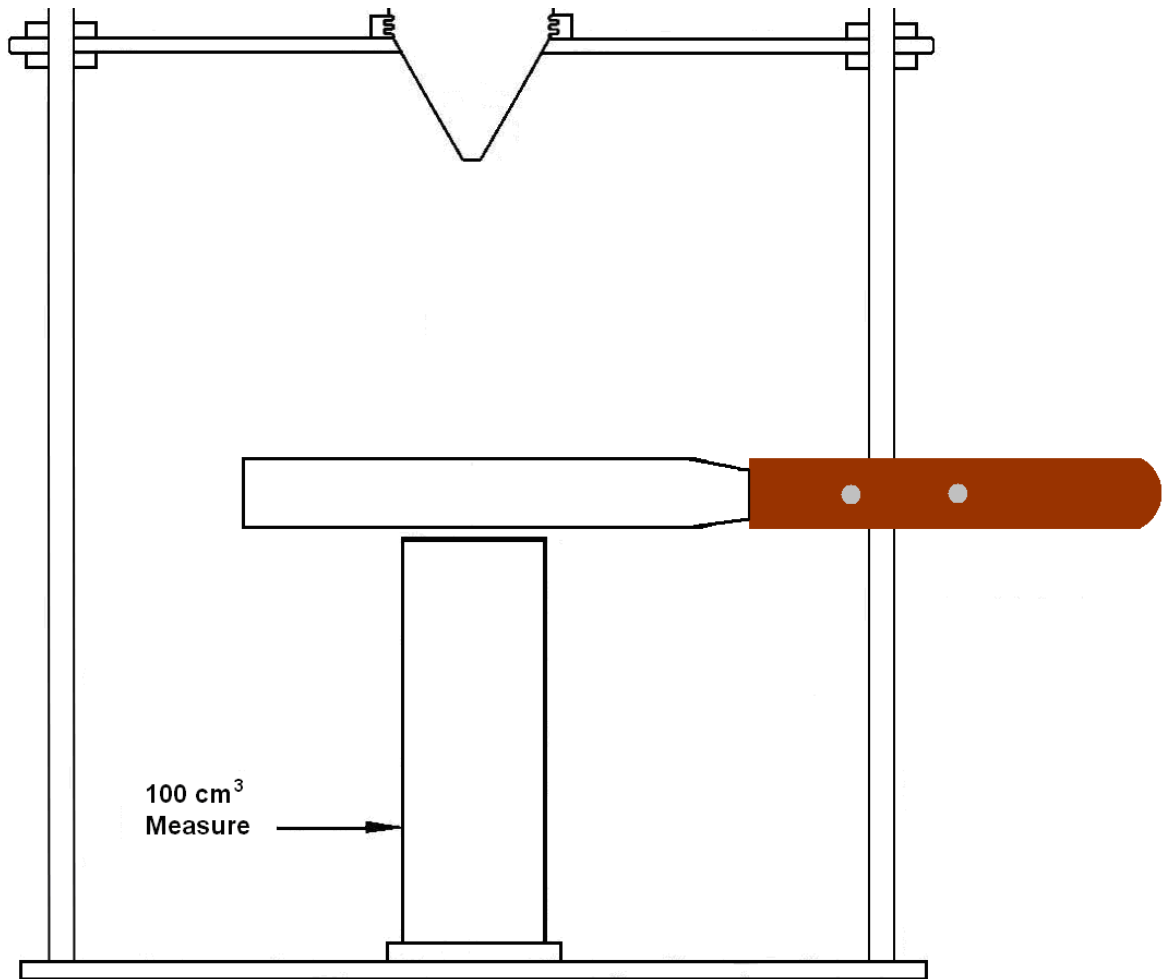

FIGURE 2



Straight Metal Spatula

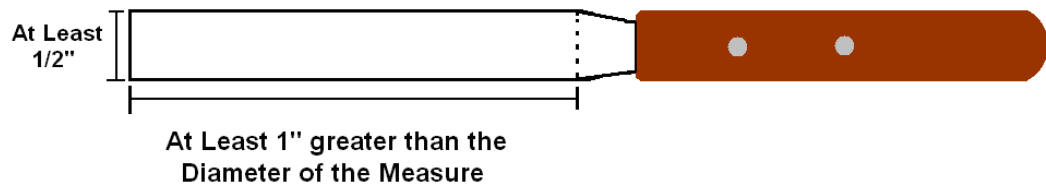

FIGURE 3