

| Pipe Dia | Distance | |
|----------|----------|--------|
| | 'X' | 'Y' |
| 16" | 6" | 1'-8" |
| 18" | 7" | 1'-10" |
| 20" | 8" | 2'-0" |
| 22" | 9" | 2'-2" |

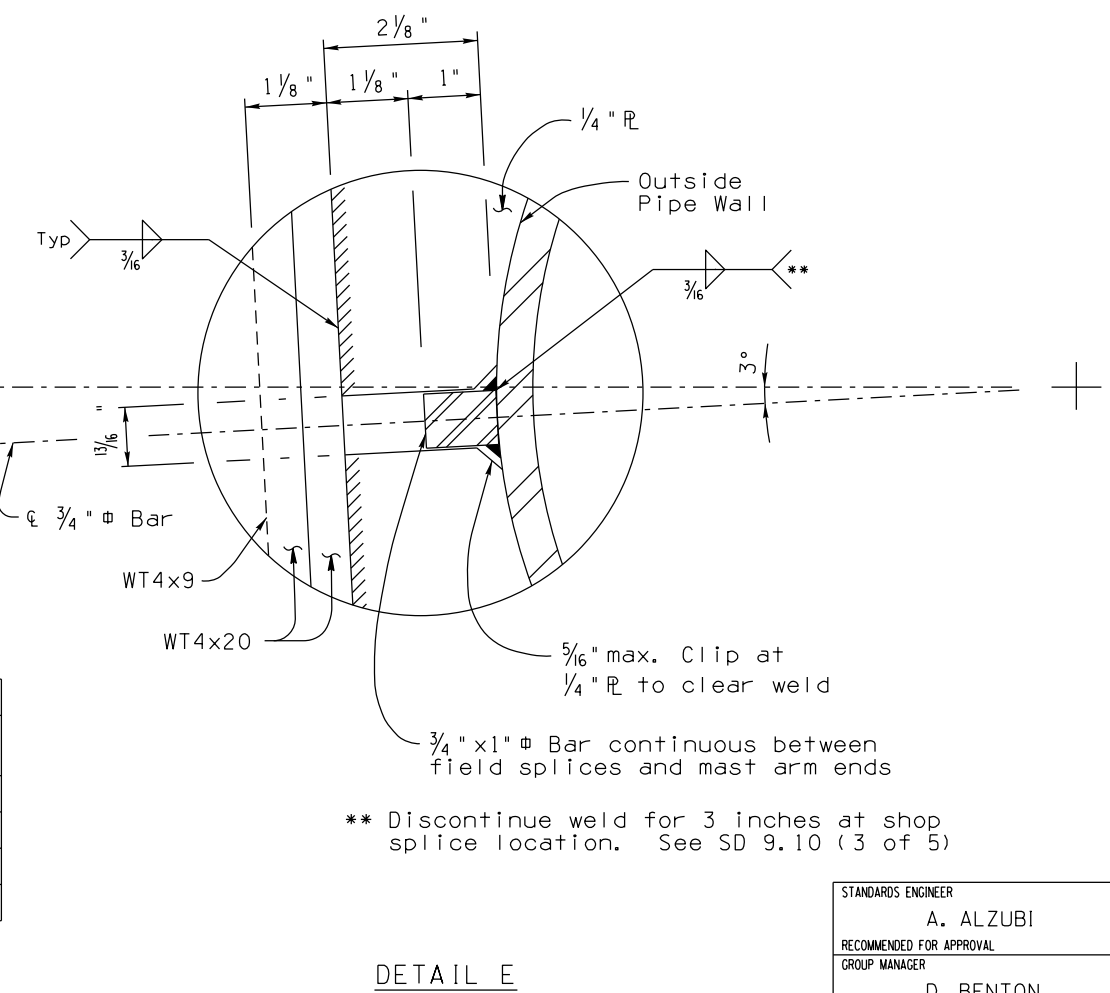

Note to Designer:
 The information presented in this Standard Drawing has been prepared in accordance with recognized engineering principles and is for general use. It should not be used for specific application without competent professional examination and verification of its suitability and applicability by a licensed professional engineer. Contents within the inner border line shall not be altered.

PRIOR DISTRIBUTION DATE 03/11

STANDARDS ENGINEER
 A. ALZUBI
 RECOMMENDED FOR APPROVAL
 GROUP MANAGER
 D. BENTON
 APPROVED
 STANDARDS COMMITTEE APPROVED FOR DISTRIBUTION 04/19 DATE

ARIZONA DEPARTMENT OF TRANSPORTATION
 INFRASTRUCTURE DELIVERY AND OPERATIONS DIVISION
BRIDGE GROUP STANDARD DRAWING
 TUBULAR SIGN STRUCTURES
 TUBULAR CANTILEVER
 SIGN SUPPORT DETAILS
 DRAWING NO.
 SD 9.10
 (4 of 5)