

NOTE:
For left catwalk details not shown, use opposite of right catwalk details shown on this drawing. Minimum Catwalk Length = 6'-6"

***NOTE:**
End spacing varies from 2'-2" Min to 4'-4" Max

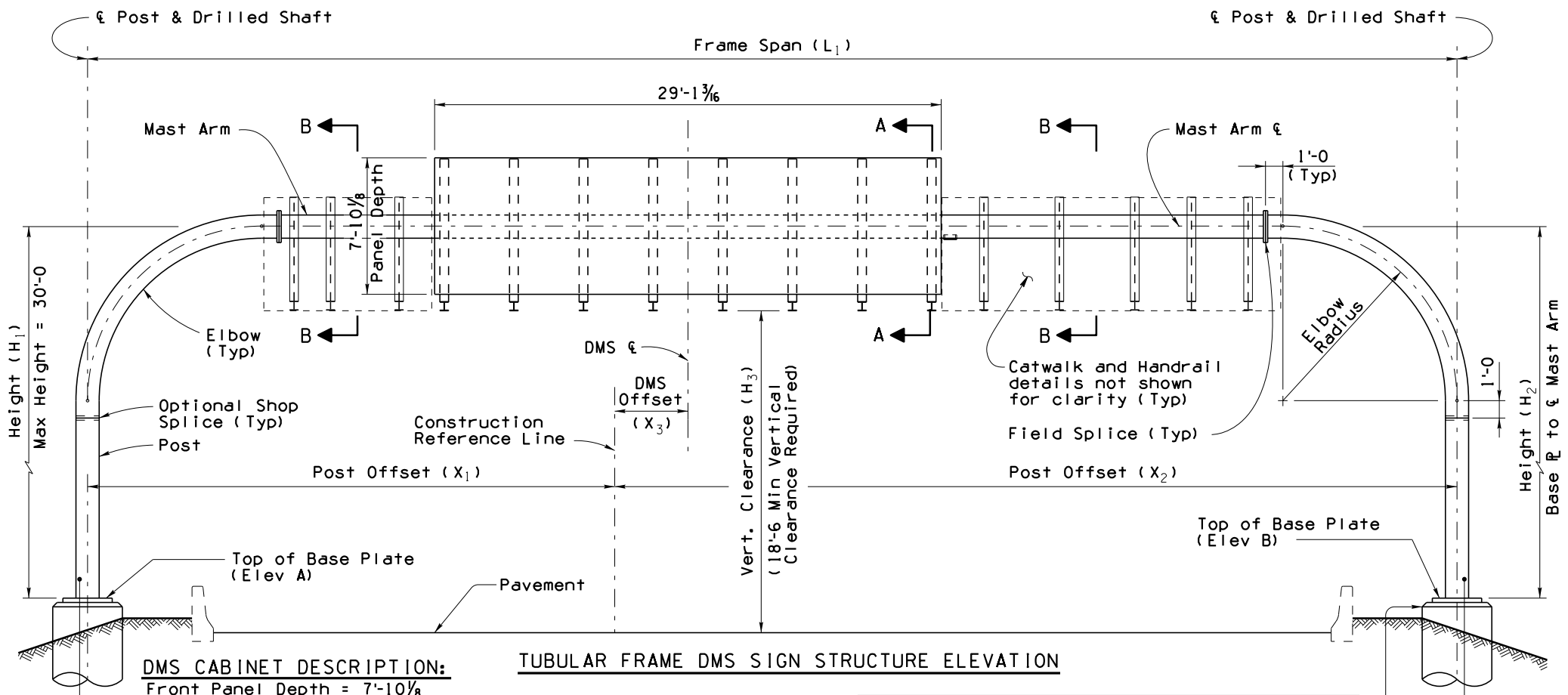

DMS CABINET DESCRIPTION:
Front Panel Depth = 7'-10 5/8"
Cabinet Depth = 7'-9 3/8"
Top of Cabinet Width = 3'-8 1/2"
Bottom of Cabinet Width = 3'-3 3/8"
Length = 29'-1 3/8"
Weight = 4000 lbs.

TUBULAR FRAME DMS SIGN STRUCTURE ELEVATION

Drilled shaft locations and top of drilled shaft elevations shall be field verified by the Contractor prior to fabrication of posts

Provide Electrical Grounding (Typ)

OVERHEAD SIGN NOTES:

Wind Loading: 90 MPH Velocity

Maximum Height: 50'-0" from average surrounding terrain to the center of the mast arm (Regardless of post height). The Tubular Overhead has been designed for site conditions which are level and neither elevated above the average surrounding terrain by more than the 50'-0" height shown nor supported on a bridge.

Maximum difference between post heights for an individual frame = 5'-0".

Additional sign attachment to the tubular frame is not allowed.

For Standard pipe mast arms with lengths greater than 60'-0" an optional field splice will be permitted at the third points of mast arm length to facilitate hauling operations. All additional field splices in the Mast Arm proposed by the fabricator will not be allowed.

The Optional Shop Splice may not be used when the splice location is less than 5'-0" above the top of base plate. Shop splice of pipe sections (other than shown) are not permitted without prior approval.

Drill and tap for 1 1/2" chase nipples and plug with recessed pipe plugs. Place perpendicular to sign panel axis and away from approaching traffic. Install nipples on shoulder posts only.

Before any portion of the tubular frame is assembled in its final position, the Contractor shall demonstrate to the Engineer by preassembly or other approved methods that the span length of the frame in the no load condition is equal to (± 1/2 inch) the field measured span length between foundations.

If the tubular frame is erected as one unit the frame shall be adequately suspended to avoid distortions or changes in span length between base plates.

The Field Splice surfaces shall be in full contact without gaps prior to the bolts being snug tightened and fully tensioned. The contact surface is the area defined by a 1 3/8" radius around each bolt.

Provide electrical grounding at pole foundations per ADOT Standard Specification Section 732-3.03.

NOTE:
Project drawings shall provide the following site specific DMS frame information on each DMS location sheet:

DMS FRAME SUMMARY TABLE	
DMS NO.:	VERTICAL CLEARANCE, H ₃ :
ROUTE:	TOP OF BASE PLATE, ELEV. A:
MILE POST:	TOP OF BASE PLATE, ELEV. B:
STATION:	POST OFFSET, X ₁ :
FRAME SPAN, L ₁ :	POST OFFSET, X ₂ :
HEIGHT, H ₁ :	DMS OFFSET, X ₃ :
HEIGHT, H ₂ :	CATWALK LENGTH, C ₁ :
	CATWALK LENGTH, C ₂ :

TUBULAR FRAME DATA FOR DMS CABINET SUPPORT						
TUBULAR FRAME				PIPE WALL THICKNESS (INCHES)		
Frame Type	Frame Span L ₁	Nominal Pipe Dia	90° Elbow Radius	Post	Elbow	Mast Arm
2F	56' - 70'	16"	10'-0"	1.219	1.219	0.500
3F	71' - 110'	20"	12'-0"	1.280	1.280	0.625
4F	111' - 142'	22"	12'-0"	1.125	1.125	0.875

NOTES:
See SD 9.50 (2 of 5) for SECTION A-A
See SD 9.50 (3 of 5) for SECTION B-B
For General Notes see SD 9.20 (1 of 5)
For Camber Diagram see SD 9.20 (3 of 5)
For Foundation Details see SD 9.20 (2 of 5)
Provide 10 inch diameter hole in center of column base plate to accommodate conduits
For Frame and Hand hole Details see SD 9.20 (3 of 5)
For Sign Support Details see SD 9.20 (4 of 5)
For Overhead Light Details see SD 9.20 (5 of 5)

STANDARDS ENGINEER
A. ALZUBI
RECOMMENDED FOR APPROVAL
GROUP MANAGER
D. EBERHART
APPROVED
STANDARDS COMMITTEE APPROVED FOR DISTRIBUTION 04/19 DATE

ARIZONA DEPARTMENT OF TRANSPORTATION
INFRASTRUCTURE DELIVERY AND OPERATIONS DIVISION
BRIDGE GROUP STANDARD DRAWING

DYNAMIC MESSAGE SIGN
TUBULAR FRAME
PLAN AND ELEVATION

DRAWING NO.
SD 9.52
(1 of 5)

Note to Designer: The information presented in this Standard Drawing has been prepared in accordance with recognized engineering principles and is for general use. It should not be used for specific application without competent professional examination and verification of its suitability and applicability by a licensed professional engineer. Contents within the inner border line shall not be altered.

03/17
PRIOR DISTRIBUTION DATE

CABINET NOTE:
 Cabinet Depth = 7'-9 5/8"
 FF Panel Depth = 7'-10 1/8"

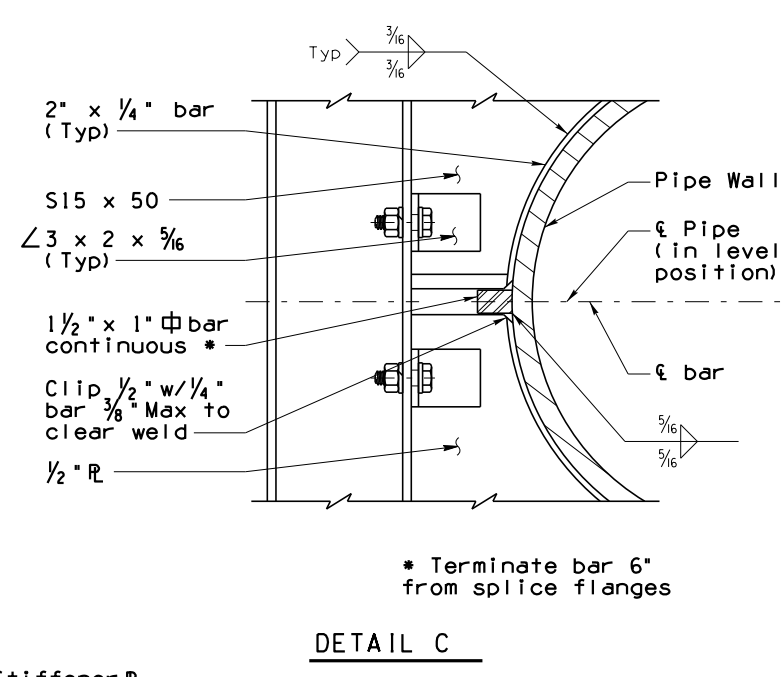
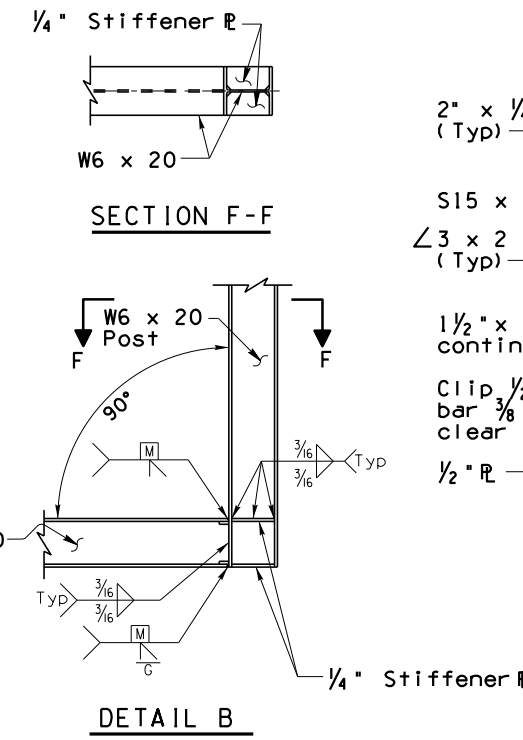
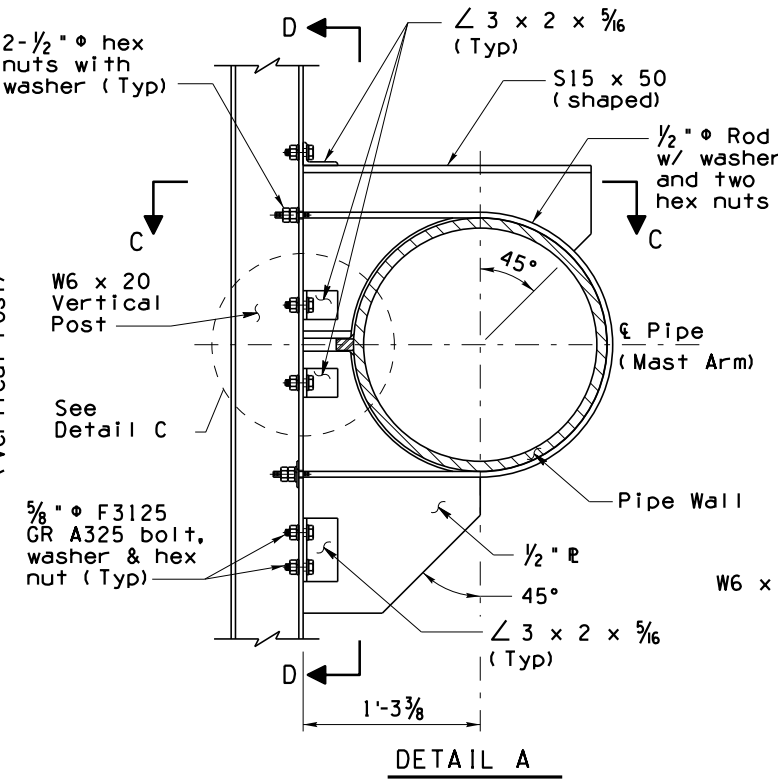
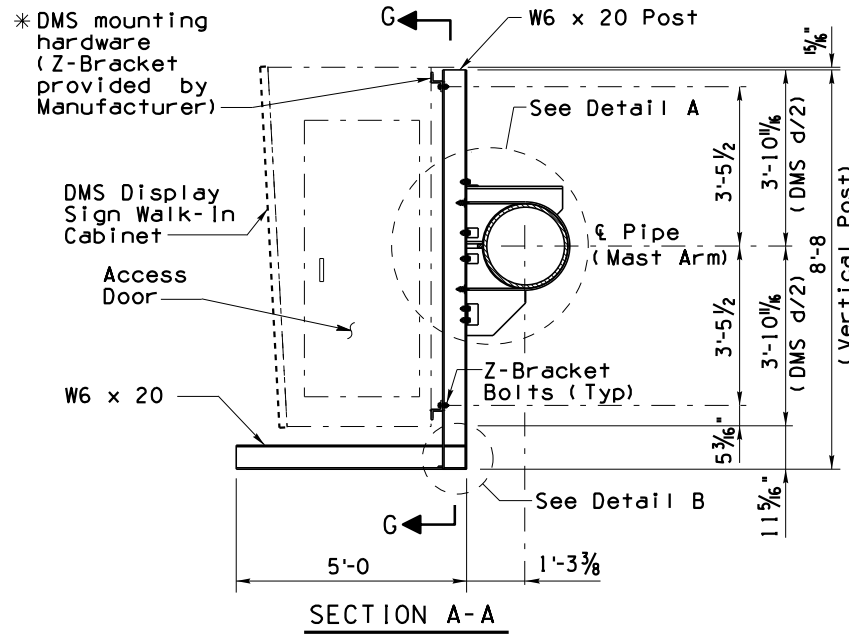

* Terminate bar 6" from splice flanges

*** Z-Bracket NOTE:**
 Barrier Tape shall be used at any point of contact between aluminum Z-Mounting Brackets (provided by Cabinet Manufacturer) and Steel Sign Supports. The Contractor shall supply Tape based on Cabinet Manufacturer's recommendations, and shall be submitted to the Engineer for approval.

NOTE:
 See Table 1 for 'a' and 'b' dimensions

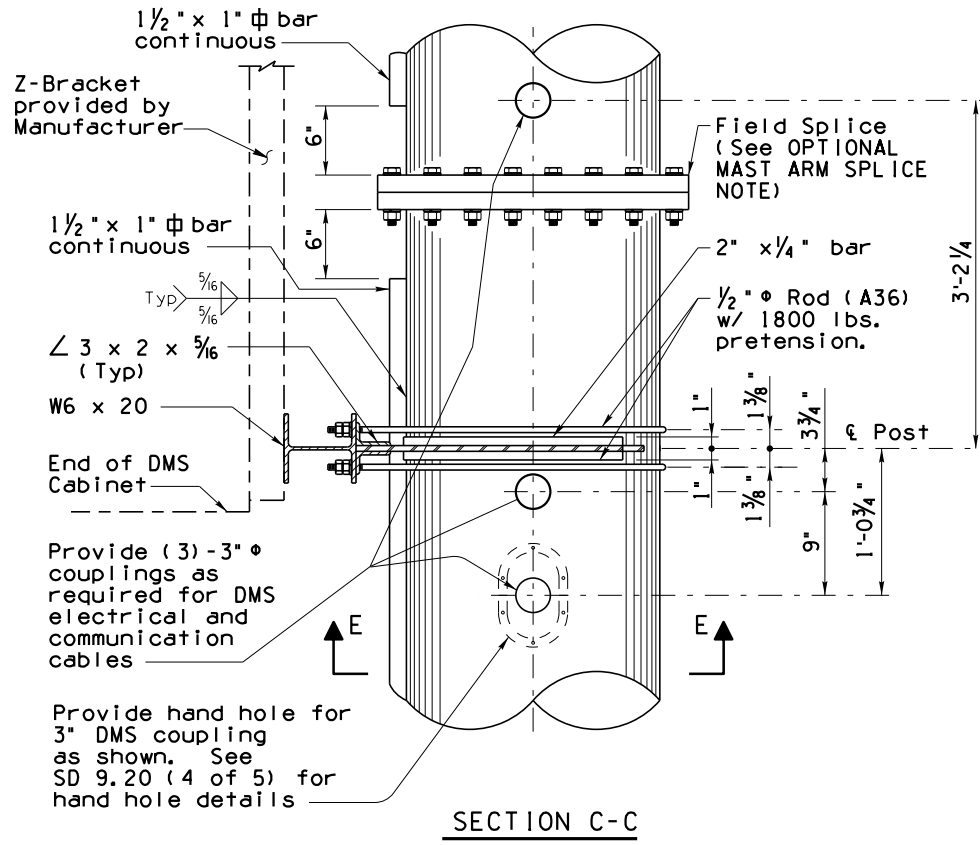
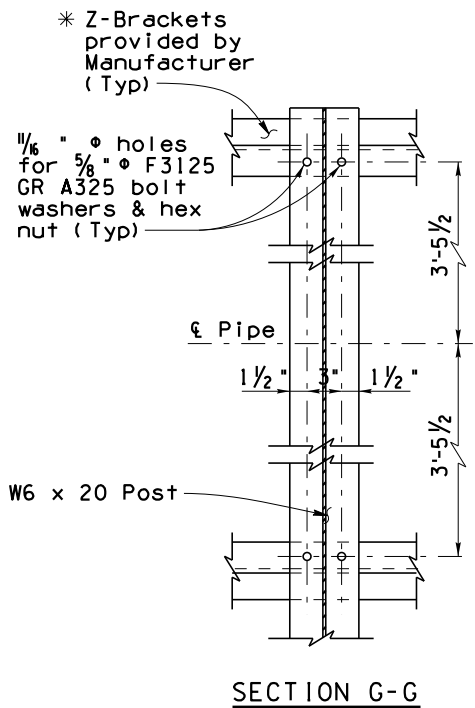
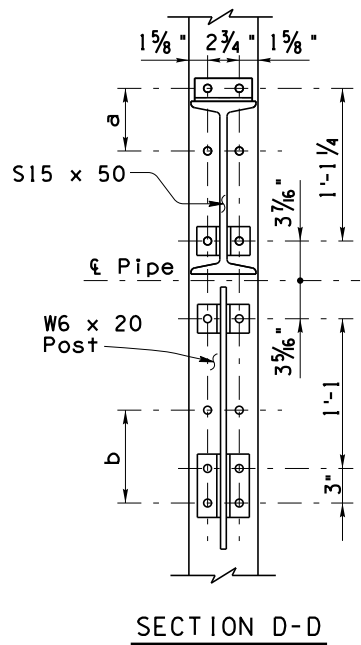

OPTIONAL MAST ARM SPLICE NOTE:
 Optional mast arm field splice, if any, shall not interfere with DMS cabinet supports, hand hole or coupling locations.

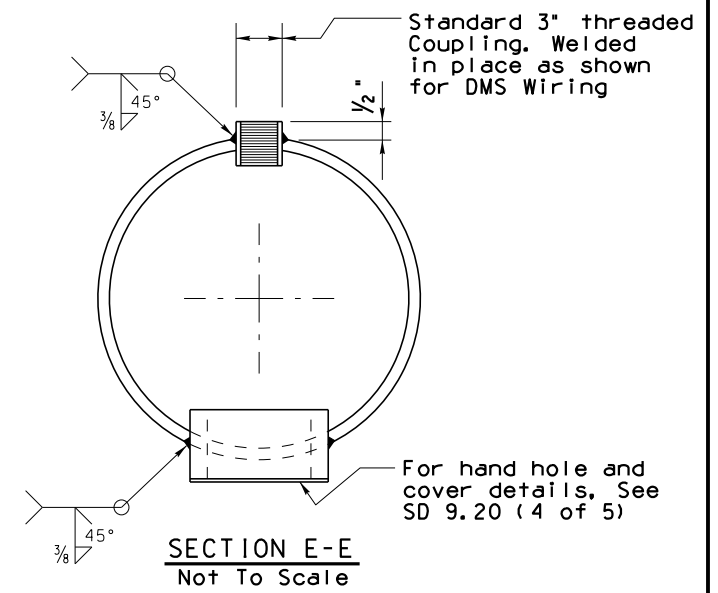

Frame Type	Nominal Pipe Dia	a	b
2F	16"	8 7/16"	11 1/16"
3F	20"	6 7/16"	9 1/16"
4F	22"	5 7/16"	8 1/16"

STANDARDS ENGINEER
A. ALZUBI
 RECOMMENDED FOR APPROVAL
 GROUP MANAGER
D. EBERHART
 APPROVED
 STANDARDS COMMITTEE APPROVED FOR DISTRIBUTION 04/19
 DATE

ARIZONA DEPARTMENT OF TRANSPORTATION
 INFRASTRUCTURE DELIVERY AND OPERATIONS DIVISION
 BRIDGE GROUP STANDARD DRAWING
 DYNAMIC MESSAGE SIGN
 TUBULAR FRAME
 MOUNTING DETAILS
 DRAWING NO.
 SD 9.52
 (2 of 5)

Note to Designer: The information presented in this Standard Drawing has been prepared in accordance with recognized engineering principles and is for general use. It should not be used for specific application without competent professional examination and verification of its suitability and applicability by a licensed professional engineer. Contents within the inner border line shall not be altered.

03/17
 PRIOR DISTRIBUTION DATE

Note to Designer: The information presented in this Standard Drawing has been prepared in accordance with recognized engineering principles and is for general use. It should not be used for specific application without competent professional examination and verification of its suitability and applicability by a licensed professional engineer. Contents within the inner border line shall not be altered.

03/17
 PRIOR DISTRIBUTION DATE

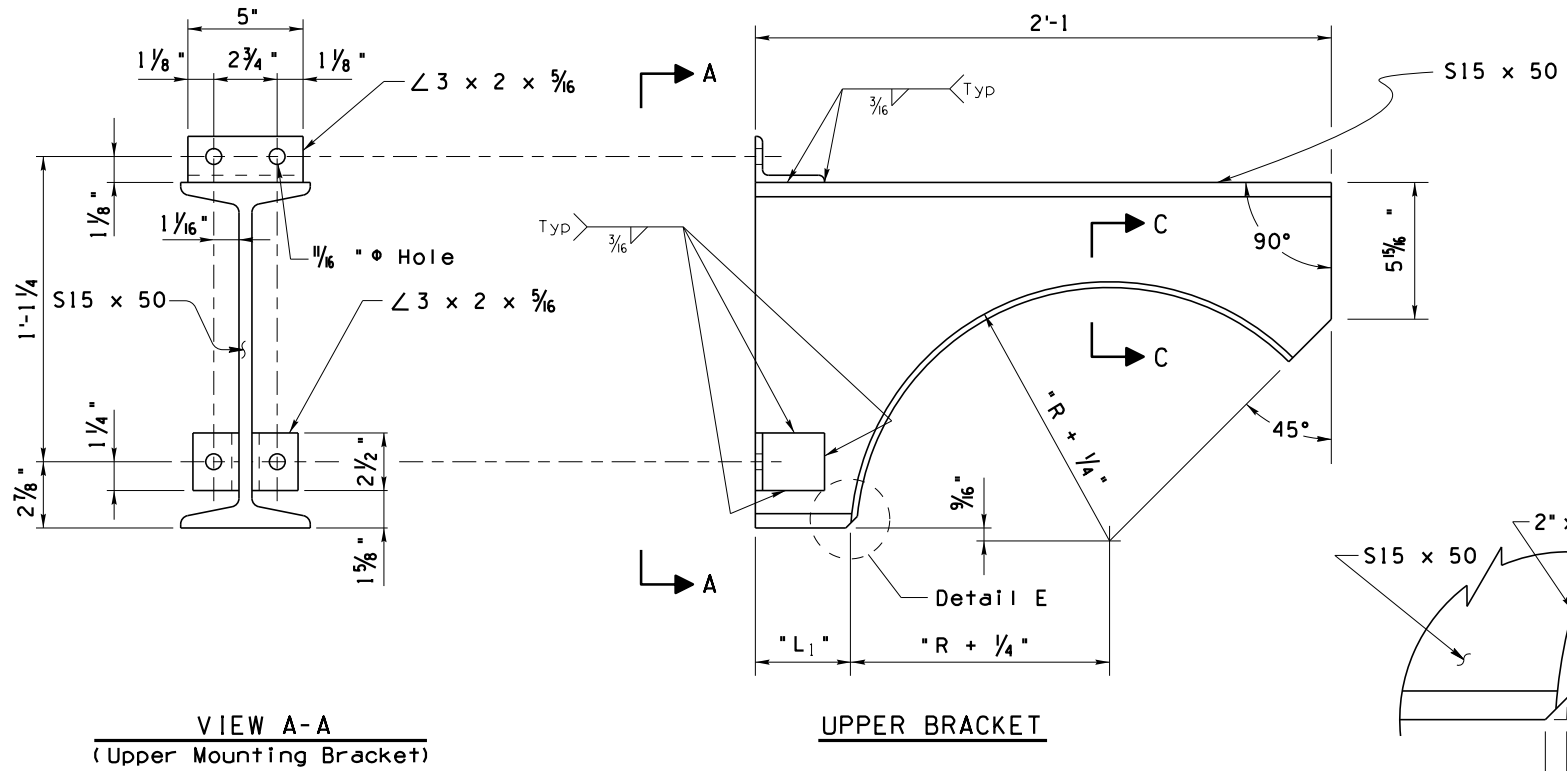

VIEW A-A
(Upper Mounting Bracket)

UPPER BRACKET

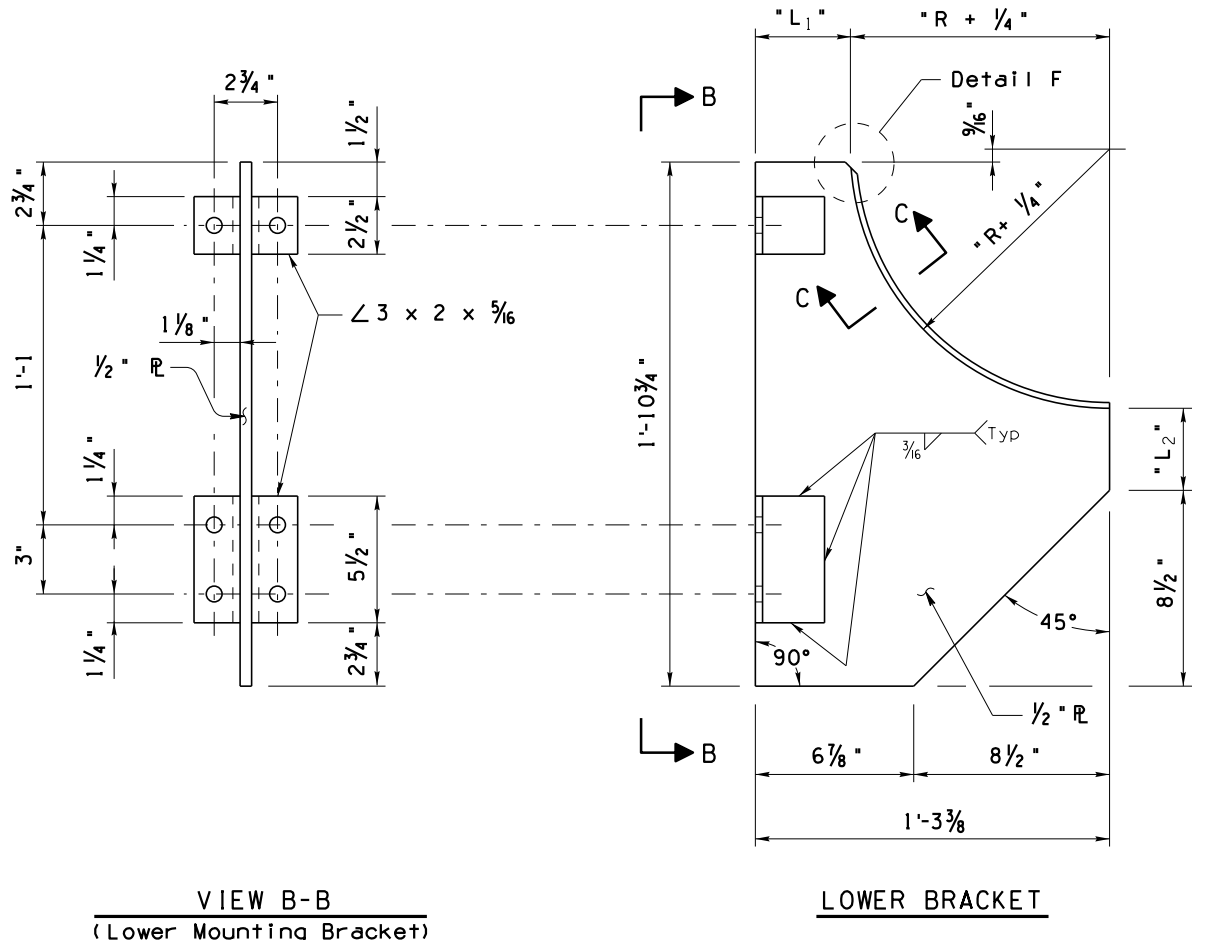

VIEW B-B
(Lower Mounting Bracket)

LOWER BRACKET

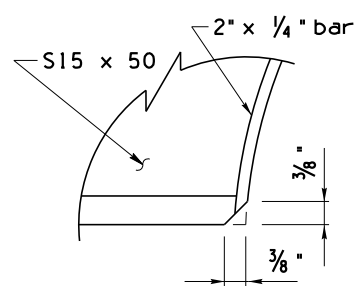

DETAIL E

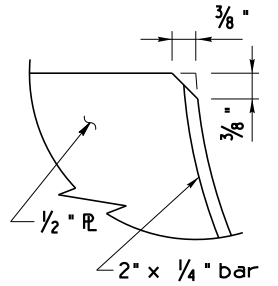

DETAIL F

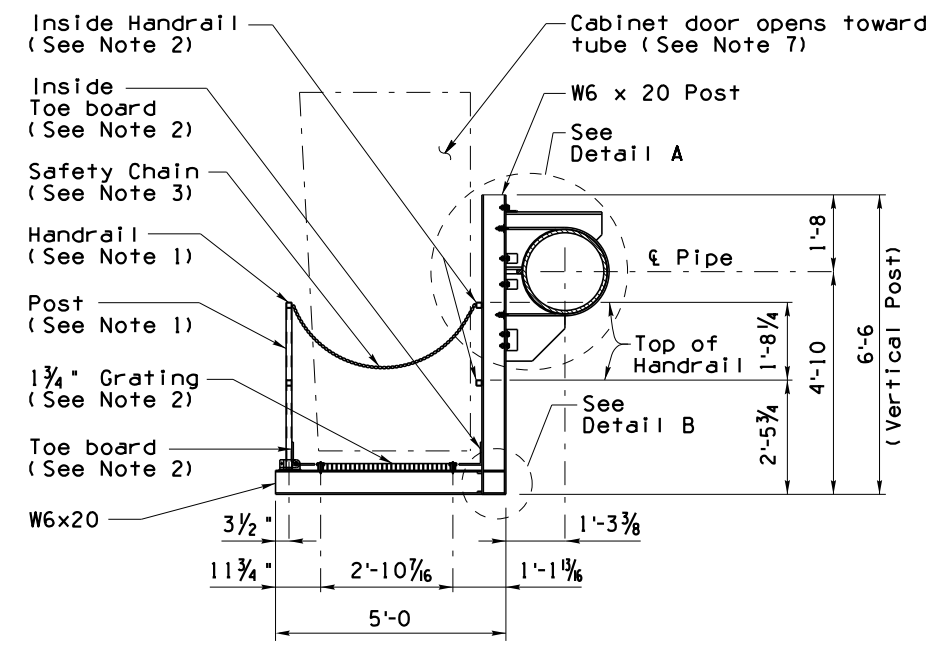

SECTION B-B

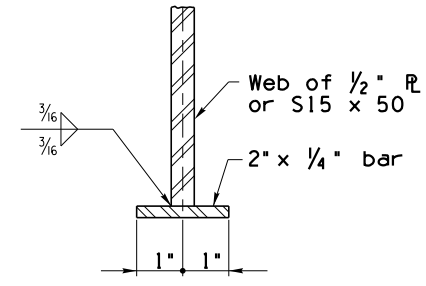

SECTION C-C

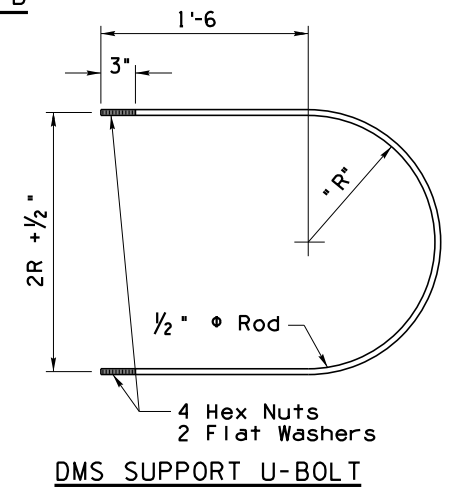

DMS SUPPORT U-BOLT

NOTES:

1. See SD 9.52 (4 of 5) for handrail, post and hinge details.
2. See SD 9.52 (5 of 5) for inside handrails, grating and toeboard details.
3. 3/16" galvanized safety chain with (1) 1/4" snap hook at end of both catwalks.
4. See SD 9.52 (2 of 5) for Detail A.
5. See SD 9.52 (2 of 5) for Detail B.
6. Optional mast arm field splice, if any, shall not interfere with catwalk supports.
7. Cabinet door hinges shall be located at tube side to allow for railing movement with door open.

Frame Type	Nominal Pipe Dia	R	L ₁	L ₂
2F	16"	8"	7 7/8"	6 9/16"
3F	20"	10"	5 5/8"	4 9/16"
4F	22"	11"	4 7/8"	3 9/16"

STANDARDS ENGINEER A. ALZUBI	ARIZONA DEPARTMENT OF TRANSPORTATION INFRASTRUCTURE DELIVERY AND OPERATIONS DIVISION BRIDGE GROUP STANDARD DRAWING
RECOMMENDED FOR APPROVAL GROUP MANAGER D. EBERHART	
APPROVED STANDARDS COMMITTEE APPROVED FOR DISTRIBUTION	DYNAMIC MESSAGE SIGN TUBULAR FRAME MOUNTING DETAILS
DATE 04/19	DRAWING NO. SD 9.52 (3 of 5)

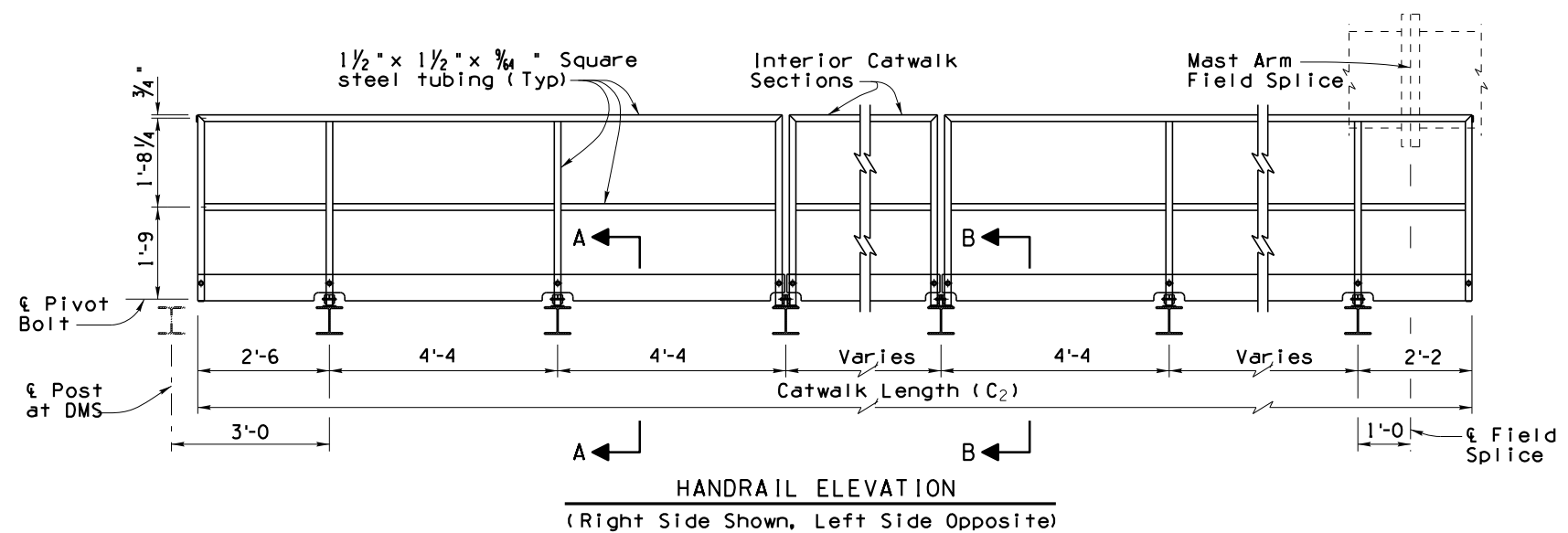

DMS TUBULAR FRAME CAMBER (INCHES)								
Frame Type	2F	2F	3F	3F	3F	4F	4F	4F
Span	56'-0	70'-0	82'-0	94'-0	106'-0	118'-0	130'-0	142'-0
"X"	1"	1 1/2"	1 3/4"	2 1/2"	3 1/2"	4"	6"	7 3/4"
"Y"	1 1/4"	2"	2 1/4"	3 1/2"	4 3/4"	6"	8 1/4"	11 1/4"

Calculated camber provides for deflections due to dead load of tubular structure and dead loads of DMS cabinet, catwalks and attachments. For spans other than shown, interpolate for "X" and "Y" dimensions.

See SD 9.20 (3 of 5) for CAMBER DIAGRAM and camber notes.

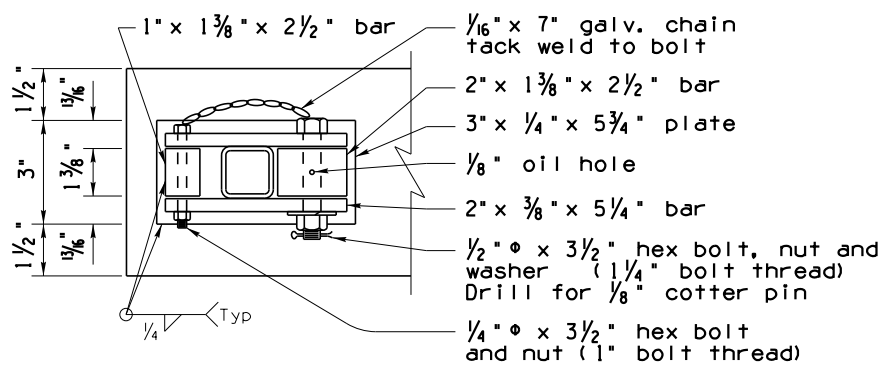

SECTION C-C
(Single Post)

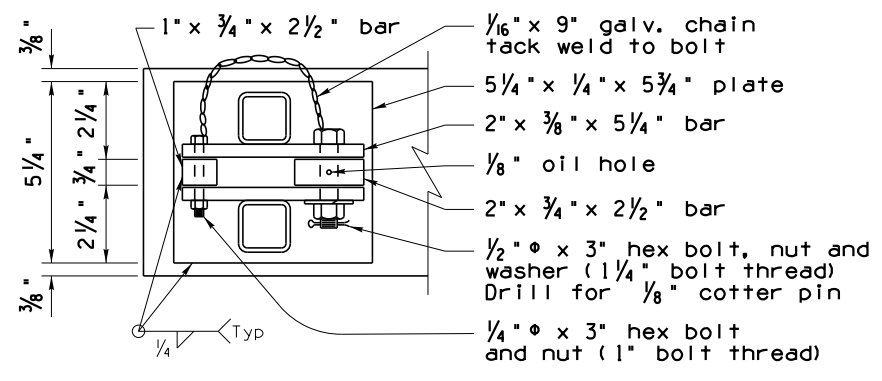

SECTION E-E
(Dual Post)

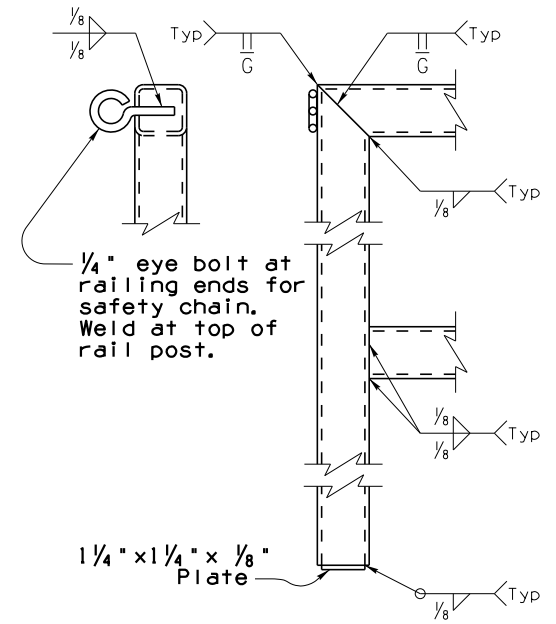

HANDRAIL WELD DETAILS

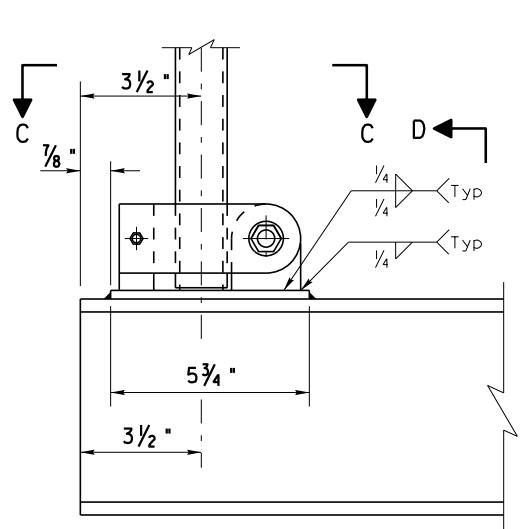

SECTION A-A
(Single Post)

See SECTION B-B for dimensions not shown

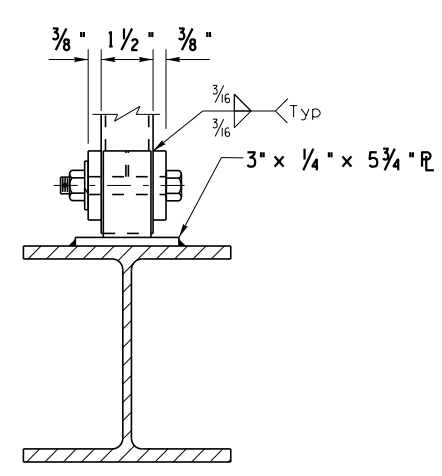

SECTION D-D
(Single Post)

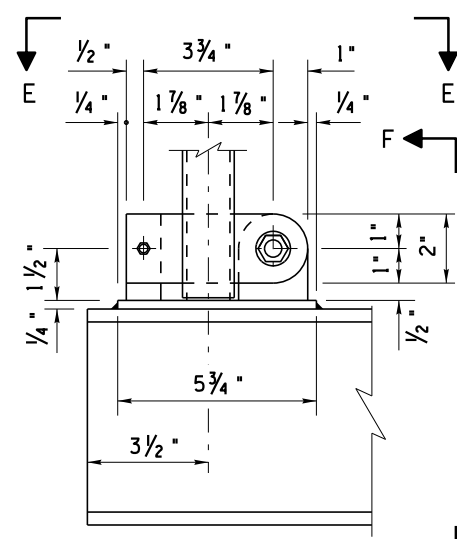

SECTION B-B
(Dual Post)

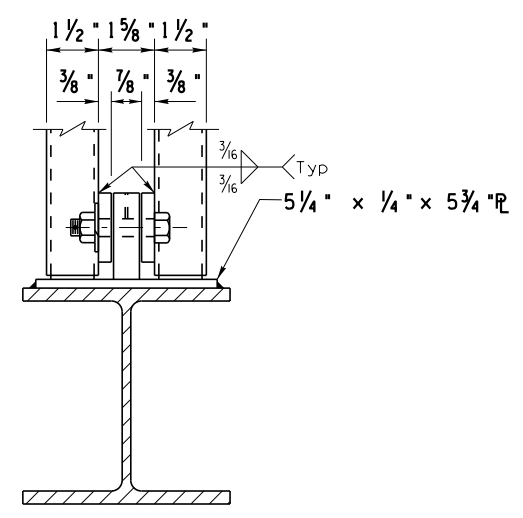

SECTION F-F
(Dual Post)

NOTES:

- Maximum support post spacing shall be 4'-4" (Maximum three spaces per rail section).
- Minimum support post spacing shall be 1'-10" (Minimum two support posts per rail section).
- Adjacent Catwalk section shall be dual post for interior sections.
- Minimum catwalk length shall be 6'-6".
- Handrail to be 1 1/2" x 1 1/2" x 3/4" square steel tubing weighing 2.70 plf.
- Provide eye bolts at ends of top handrails for 3/16" galvanized safety chain with (1) 1/4" snap hook per catwalk end.
- Provide 5/8" holes for 1/2" pivot bolts and 3/8" holes for 1/4" lock bolts.
- See SD 9.52 (5 of 5) for inside handrails, grating and toeboard details.

Note to Designer: The information presented in this Standard Drawing has been prepared in accordance with recognized engineering principles and is for general use. It should not be used for specific application without competent professional examination and verification of its suitability and applicability by a licensed professional engineer. Contents within the inner border line shall not be altered.

03/17
 PRIOR DISTRIBUTION DATE

STANDARDS ENGINEER A. ALZUBI RECOMMENDED FOR APPROVAL GROUP MANAGER APPROVED STANDARDS COMMITTEE APPROVED FOR DISTRIBUTION	ARIZONA DEPARTMENT OF TRANSPORTATION INFRASTRUCTURE DELIVERY AND OPERATIONS DIVISION BRIDGE GROUP STANDARD DRAWING DYNAMIC MESSAGE SIGN TUBULAR FRAME HANDRAIL DETAILS	DRAWING NO. SD 9.52 (4 of 5)
DATE 04/19		

Note to Designer: The information presented in this Standard Drawing has been prepared in accordance with recognized engineering principles and is for general use. It should not be used for specific application without competent professional examination and verification of its suitability and applicability by a licensed professional engineer. Contents within the inner border line shall not be altered.

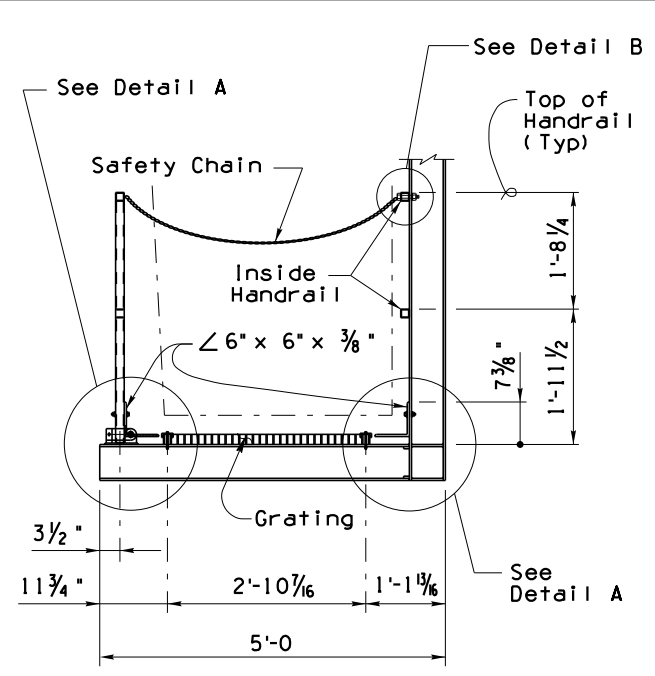

PART. SECTION OF DMS CATWALK

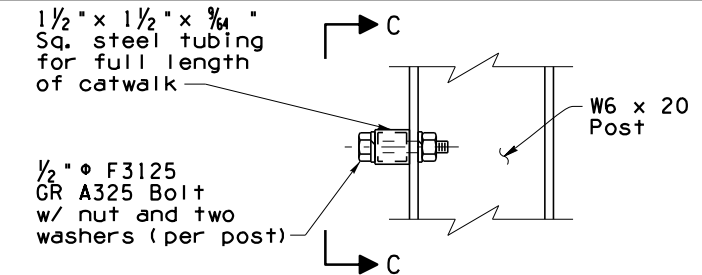

DETAIL B

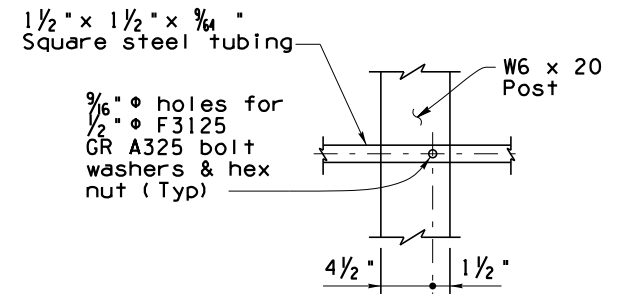

SECTION C-C

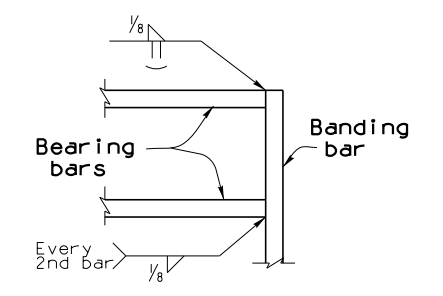

DETAIL C

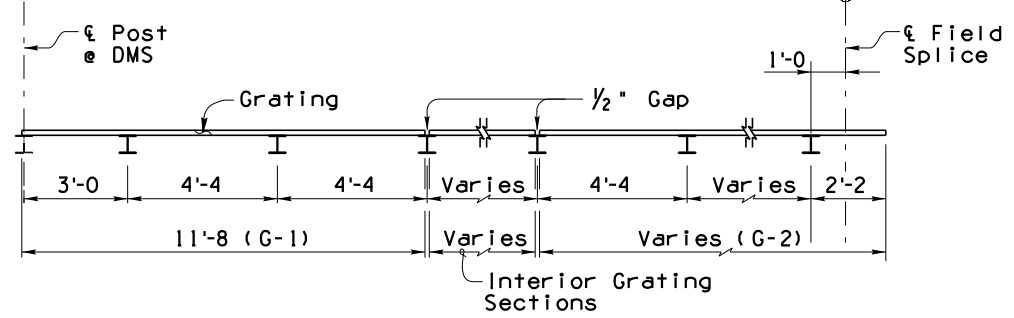

GRATING ELEVATION
(Right Side Shown, Left Side Opposite)

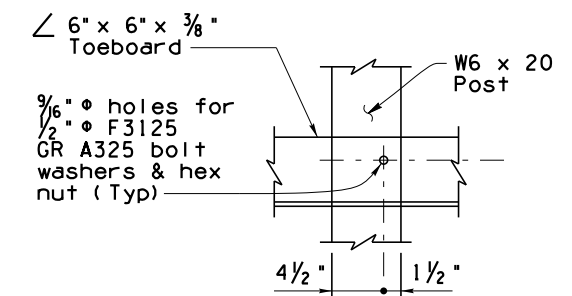

SECTION B-B

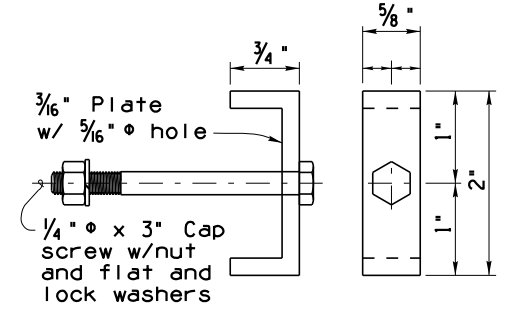

GRATING CLIP

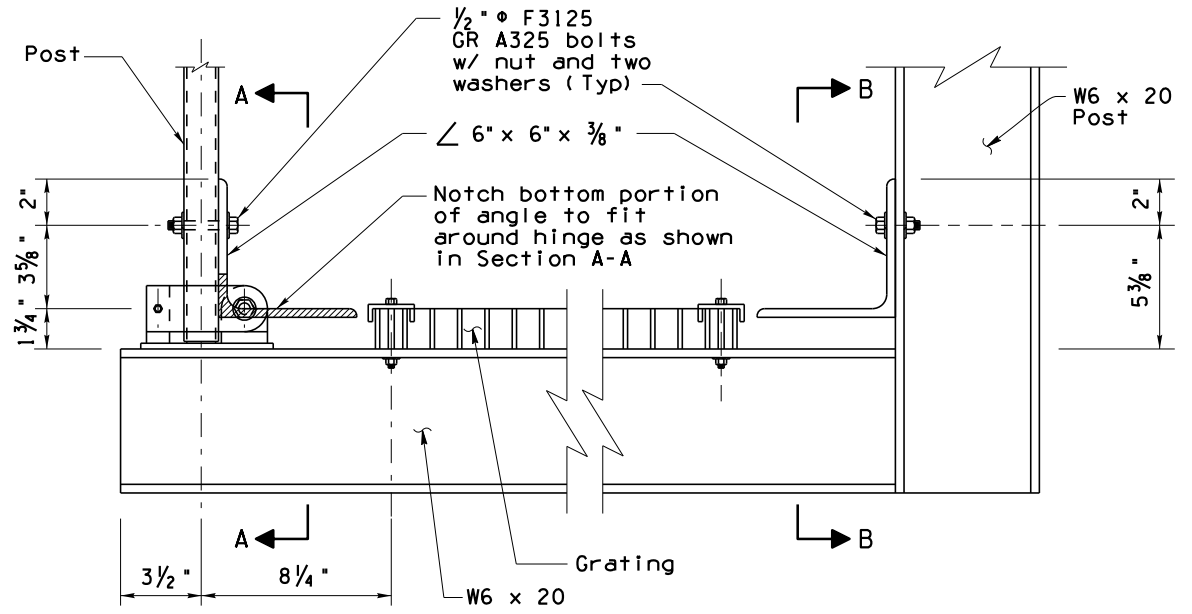

DETAIL A

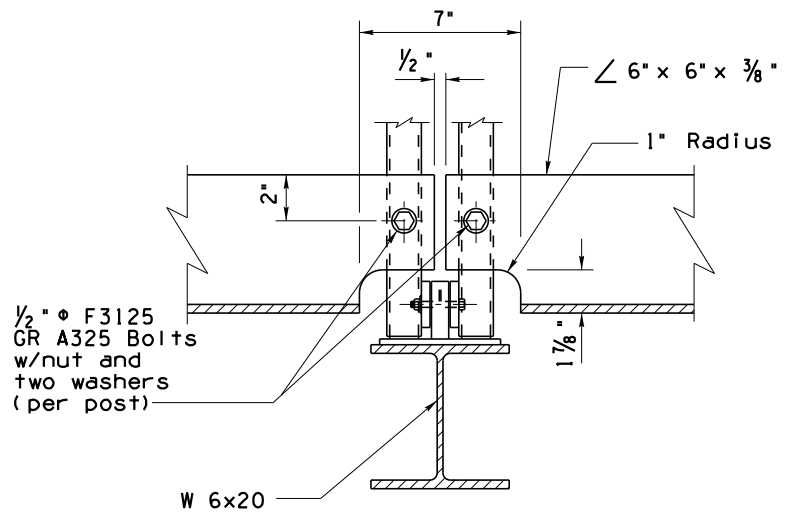

SECTION A-A
(Dual Posts)

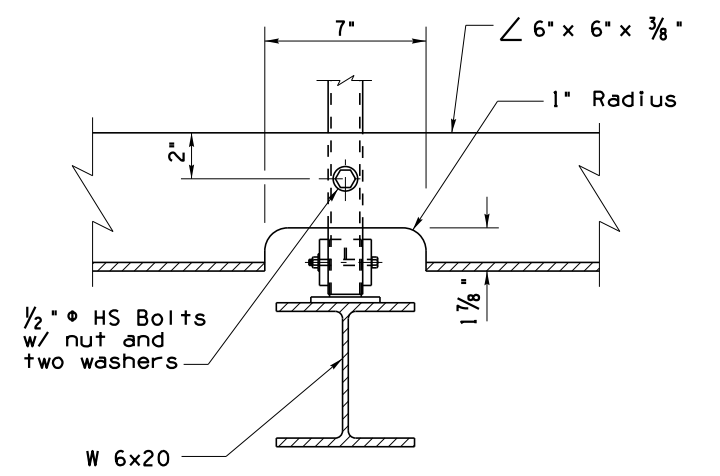

SECTION A-A
(Single Post)

NOTES:

- 1. Welded grating shall meet the standard requirements of ANS/NAAMM MGB 531-00. Grating shall be 1 3/4" x 3/16" bearing bars at 1 3/16" centers and cross bars at 4" centers.
- 2. All grating to have 1 3/4" x 3/16" banding bars at both ends.
- 3. Weld bearing bars to banding bars with 1/8" fillet weld, one side every second bar and as shown in Detail C.
- 4. All grating to be straight and true after fabrication.
- 5. Grating shall be galvanized.
- 6. See Table at right for grating dimensions:

GRATING DIMENSIONS		
Grate No.	Length	Width
G-1	11'-8"	2'-11 13/16"
Interior	Varies**	2'-11 13/16"
G-2	Varies*	2'-11 13/16"

* Maximum length of G-2 is 10'-6"
 ** Use additional interior grating sections of 4'-3 1/2", 8'-7 1/2" or 12'-11 1/2" if required

STANDARDS ENGINEER A. ALZUBI	ARIZONA DEPARTMENT OF TRANSPORTATION INFRASTRUCTURE DELIVERY AND OPERATIONS DIVISION BRIDGE GROUP STANDARD DRAWING	DRAWING NO. SD 9.52 (5 of 5)
RECOMMENDED FOR APPROVAL GROUP MANAGER D. EBERHART		
APPROVED STANDARDS COMMITTEE APPROVED FOR DISTRIBUTION	DYNAMIC MESSAGE SIGN TUBULAR FRAME MISCELLANEOUS DETAILS	DATE 04/19