

Note to Designer: The information presented in this Standard Drawing has been prepared in accordance with recognized engineering principles and is for general use. It should not be used for specific application without competent professional examination and verification of its suitability and applicability by a licensed professional engineer. Contents within the inner border line shall not be altered.

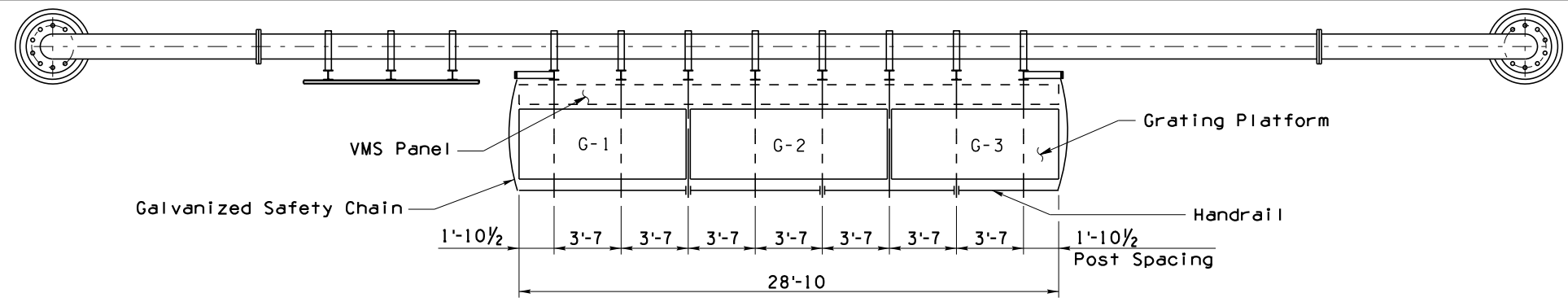

**PLAN**

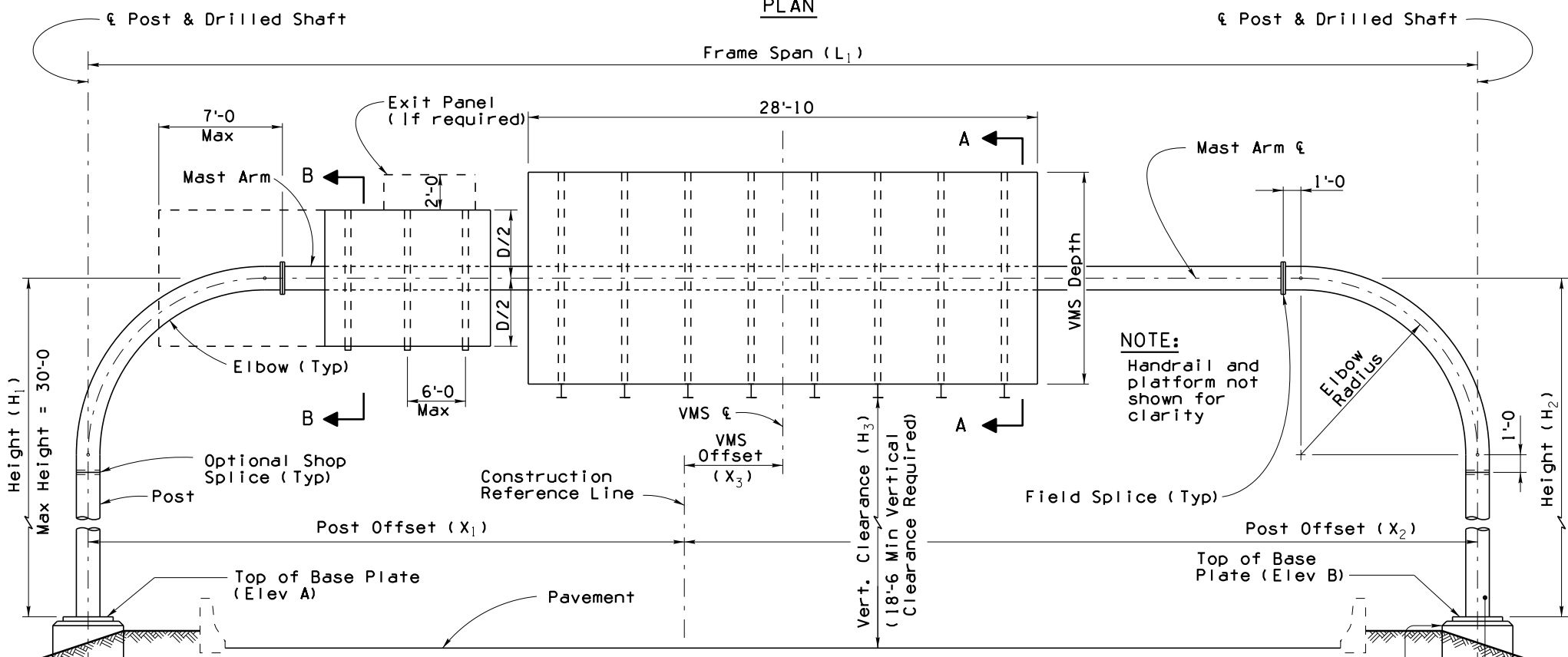

**TUBULAR FRAME SIGN STRUCTURE ELEVATION**

Scale: 1/4" = 1'-0"

**VMS DESCRIPTION**

Depth = 9'-2  
 Length = 28'-10  
 Weight = 3000 lbs.

**TUBULAR FRAME DATA FOR VMS PANEL SUPPORT**

TYPE	TUBULAR FRAME			PIPE WALL THICKNESS (INCHES)			Max Sign Depth D*	Max Sign Area Sq. Ft. **
	Frame Span L <sub>1</sub>	Nominal Pipe Dia	90° ELBOW RADIUS	Post	Elbow	Mast Arm		
1F	20' - 40'	12"	10'-0	1.312	1.312	1.000		VMS
2F	41' - 70'	16"	10'-0	1.219	1.219	0.500	12'	VMS+400
3F	71' - 110'	20"	12'-0	1.280	1.280	0.625	12'	VMS+560
4F	111' - 142'	22"	12'-0	1.125	1.125	0.875	12'	VMS+560

\* For additional traffic sign panels  
 \*\* Includes 2'-0 Exit Panel

Drilled shaft locations and top of drilled shaft elevations shall be field verified by the Contractor prior to fabrication of posts.

Project drawings shall provide the following site specific VMS frame information on VMS location sheets:

VMS FRAME SUMMARY TABLE	
VMS NO.:	VERTICAL CLEARANCE, H <sub>3</sub> :
ROUTE:	TOP OF BASE PLATE, Elev A:
MILE POST:	TOP OF BASE PLATE, Elev B:
STATION:	POST OFFSET, X <sub>1</sub> :
FRAME SPAN, L <sub>1</sub> :	POST OFFSET, X <sub>2</sub> :
HEIGHT, H <sub>1</sub> :	VMS OFFSET, X <sub>3</sub> :
HEIGHT, H <sub>2</sub> :	

**OVERHEAD SIGN NOTES:**

Wind Loading: 90 MPH Velocity  
  
 Maximum Height: 50'-0 from average surrounding terrain to the  $\epsilon$  of the mast arm (Regardless of post height). The Tubular Overhead has been designed for site conditions which are level and neither elevated above the average surrounding terrain by more than the 50'-0 height shown nor supported on a bridge.  
  
 Maximum difference between post heights for an individual frame = 5'-0.  
  
 The maximum sign panel overlap onto elbow shall not exceed 7'-0 from field splice.  
  
 The sum of the sign panel area plus the exit panel area shall not exceed the maximum area shown in table. All signs shall be placed within Sign Panel Location.  
  
 For Standard pipe mast arms with lengths greater than 60'-0 an optional field splice will be permitted at the third points of mast arm length to facilitate hauling operations. All additional field splices in the Mast Arm proposed by the fabricator will not be allowed.

The Optional Shop Splice may not be used when the splice location is less than 5'-0 above the top of base plate. Shop splice of pipe sections (other than shown) are not permitted without prior approval.

Drill and tap for 1 1/2" chase nipples and plug with recessed pipe plugs. Place perpendicular to sign panel axis and away from approaching traffic. Install nipples on shoulder posts only.

Before any portion of the tubular frame is assembled in its final position, the Contractor shall demonstrate to the Engineer by preassembly or other approved methods that the span length of the frame in the no load condition is equal to ( $\pm 1/2$  inch) the field measured span length between foundations.

If the tubular frame is erected as one unit the frame shall be adequately suspended to avoid distortions or changes in span length between base plates.

The Field Splice surfaces shall be in full contact without gaps prior to the bolts being snug tightened and fully tensioned. The contact surface is the area defined by a 1 3/8" radius around each bolt.

Provide electrical grounding at pole foundations per ADOT Standard Specification Section 732-3.03.

**NOTES:**

See SD 9.50 (2 of 5) for SECTION A-A  
 See SD 9.50 (3 of 5) for SECTION B-B  
 For General Notes see SD 9.20 (1 of 5)  
 For Camber Diagram see SD 9.20 (3 of 5)  
 For Foundation Details see SD 9.20 (2 of 5)  
 Provide 10 inch diameter hole in center of column base plate to accommodate conduits  
 For Frame and Hand hole Details see SD 9.20 (3 of 5)  
 For Sign Support Details see SD 9.20 (4 of 5)  
 For Overhead Light Details see SD 9.20 (5 of 5)

STANDARDS ENGINEER <b>A. ALZUBI</b> RECOMMENDED FOR APPROVAL GROUP MANAGER	ARIZONA DEPARTMENT OF TRANSPORTATION INFRASTRUCTURE DELIVERY AND OPERATIONS DIVISION BRIDGE GROUP STANDARD DRAWING
APPROVED <b>D. EBERHART</b> STANDARDS COMMITTEE APPROVED FOR DISTRIBUTION	VARIABLE MESSAGE SIGN TUBULAR FRAME PLAN AND ELEVATION
DATE: 04/19	DRAWING NO. <b>SD 9.50</b> (1 of 5)

Note to Designer: The information presented in this Standard Drawing has been prepared in accordance with recognized engineering principles and is for general use. It should not be used for specific application without competent professional examination and verification of its suitability and applicability by a licensed professional engineer. Contents within the inner border line shall not be altered.

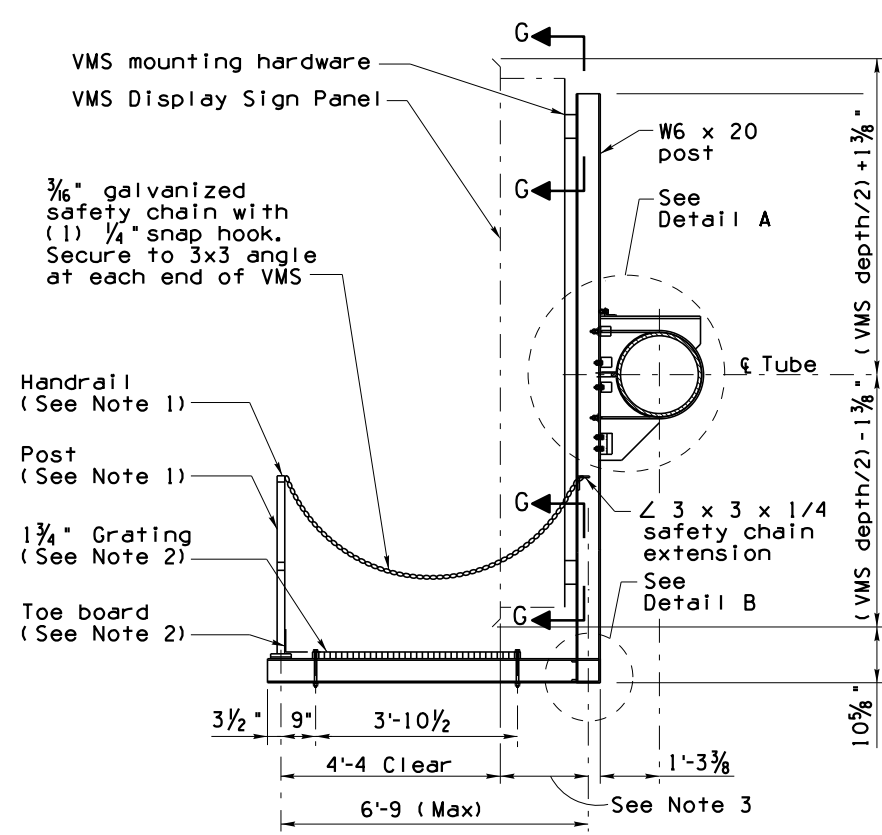

SECTION A-A

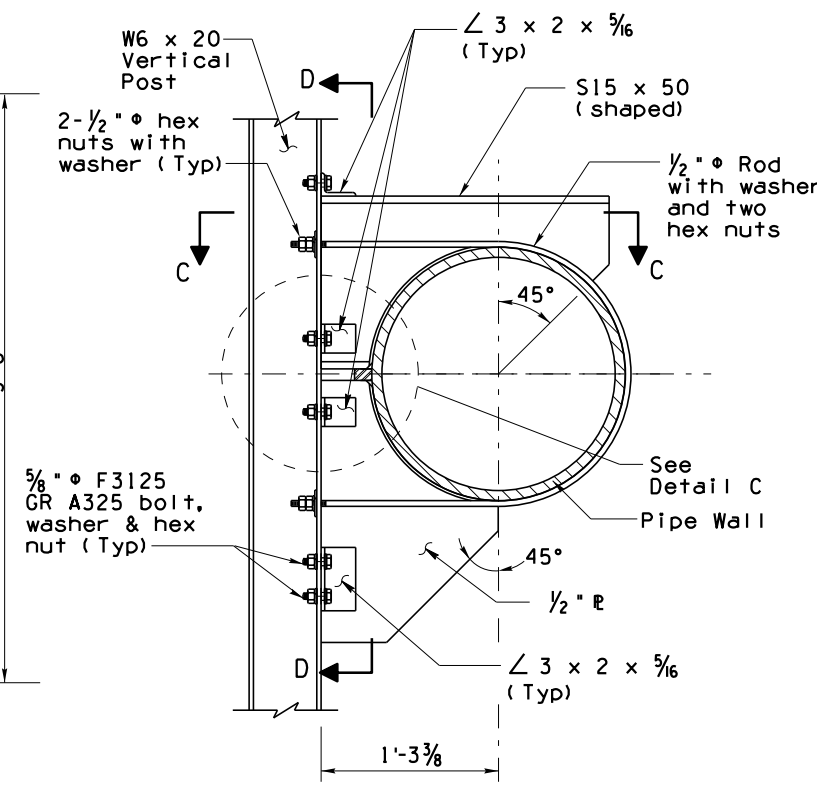

DETAIL A

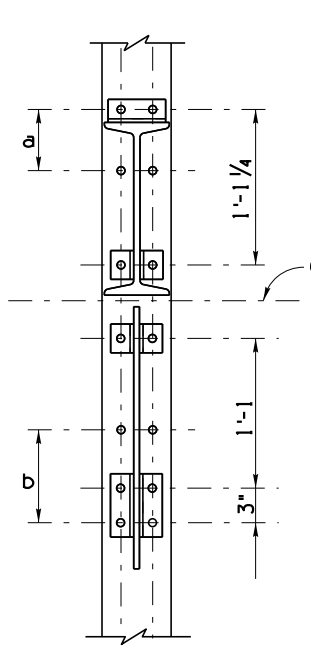

SECTION D-D

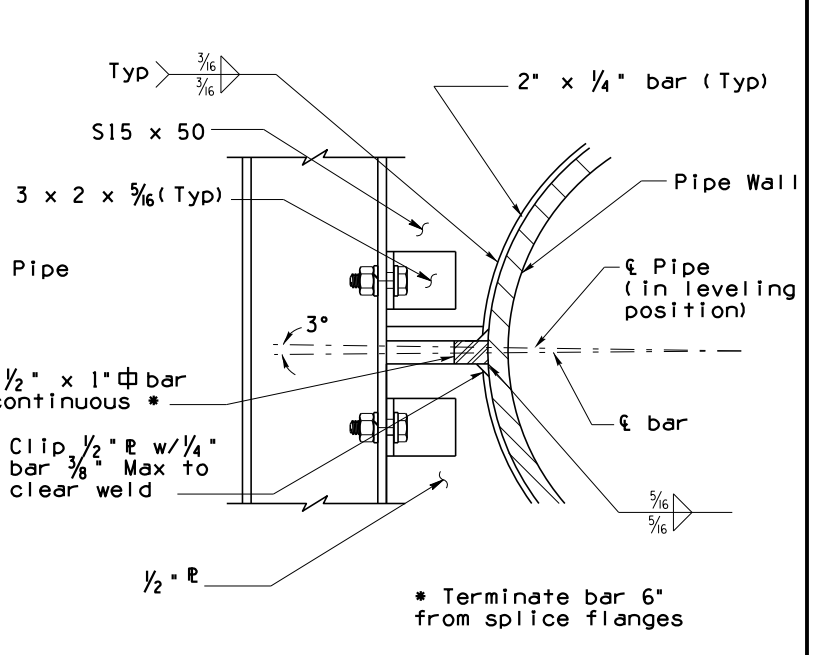

DETAIL C

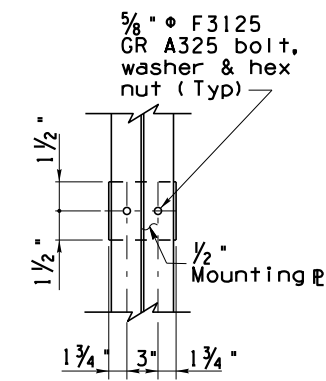

SECTION G-G

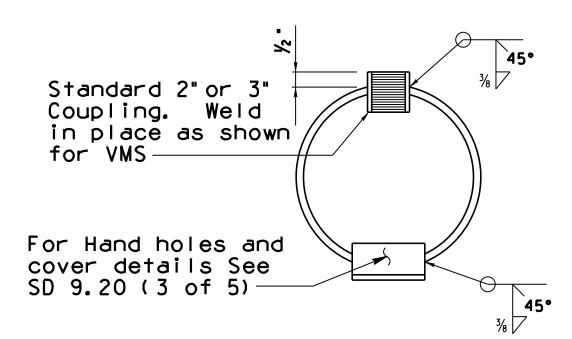

SECTION E-E

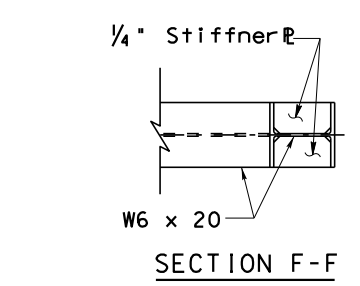

SECTION F-F

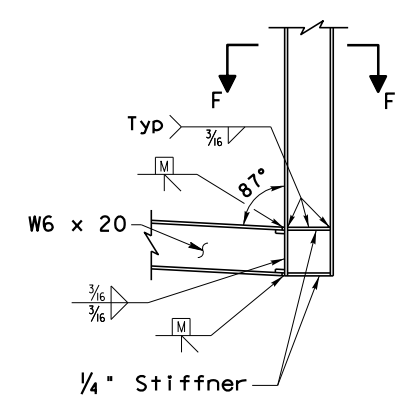

DETAIL B

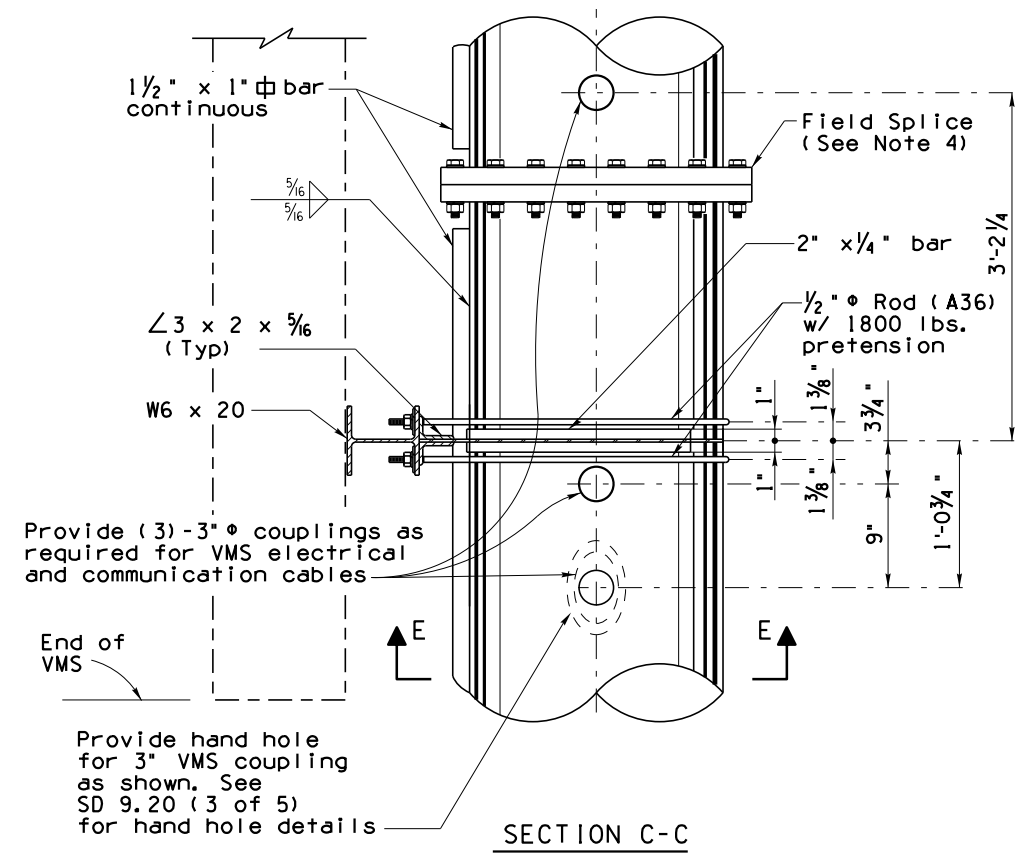

SECTION C-C

**NOTES:**

1. See SD 9.50 (4 of 5) for handrail, post and hinge details.
2. See SD 9.50 (5 of 5) for grating and toeboard details.
3. Dimensions to be determined from VMS sign manufacturer. Grating shall extend under face of VMS sign panel.
4. Optional mast arm field splice, if any, shall not interfere with VMS panel supports, hand hole or coupling locations.

Frame Type	Nominal Pipe Dia	R	a	b
1F	12"	6 3/8"	10 1/16"	12 1/16"
2F	16"	8"	8 7/16"	11 1/16"
3F	20"	10"	6 7/16"	9 1/16"
4F	22"	11"	5 7/16"	8 1/16"

STANDARDS ENGINEER <b>A. ALZUBI</b> RECOMMENDED FOR APPROVAL GROUP MANAGER	ARIZONA DEPARTMENT OF TRANSPORTATION INFRASTRUCTURE DELIVERY AND OPERATIONS DIVISION BRIDGE GROUP STANDARD DRAWING
APPROVED <b>D. EBERHART</b> STANDARDS COMMITTEE APPROVED FOR DISTRIBUTION	VARIABLE MESSAGE SIGN TUBULAR FRAME MOUNTING DETAILS
08/02 PRIOR DISTRIBUTION DATE	DRAWING NO. <b>SD 9.50</b> (2 of 5)

Note to Designer: The information presented in this Standard Drawing has been prepared in accordance with recognized engineering principles and is for general use. It should not be used for specific application without competent professional examination and verification of its suitability and applicability by a licensed professional engineer. Contents within the inner border line shall not be altered.

08/02  
 PRIOR DISTRIBUTION DATE

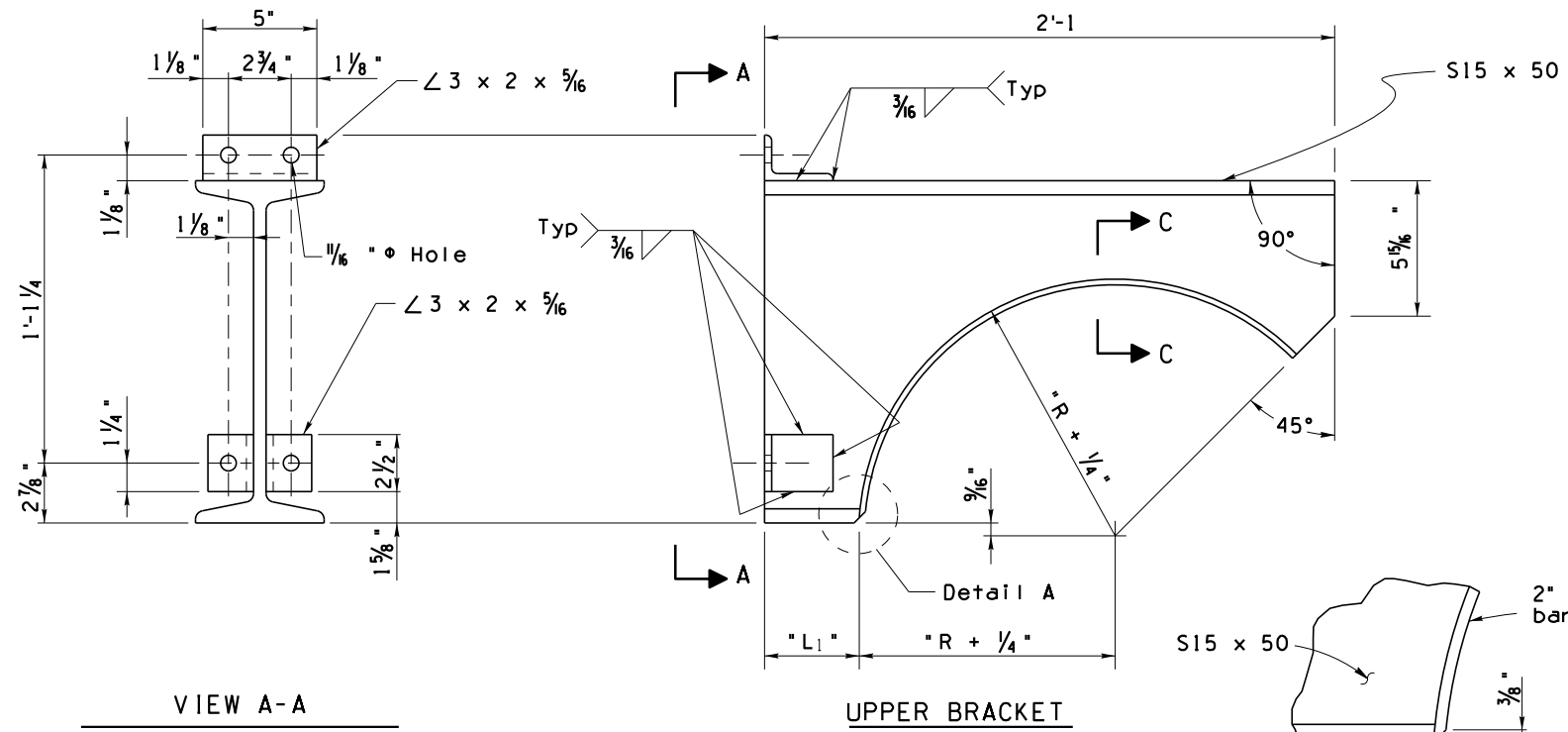

**VIEW A-A**  
Sign Support Mounting - Upper Bracket

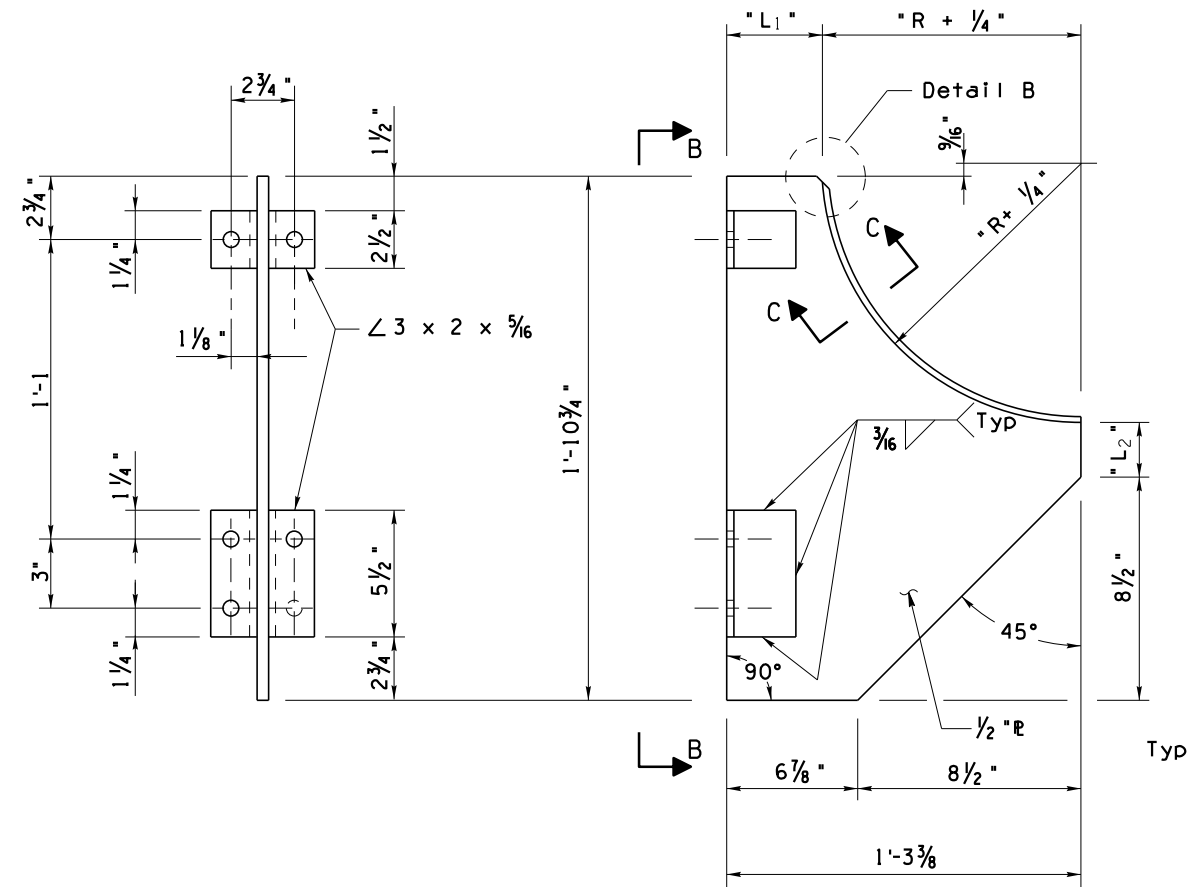

**VIEW B-B**  
Sign Support Mounting - Lower Bracket

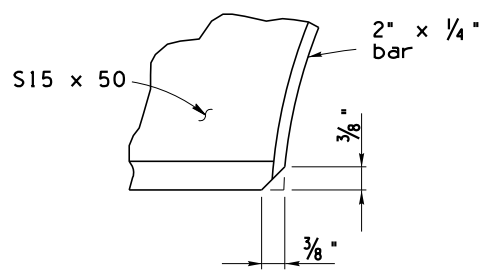

**DETAIL A**

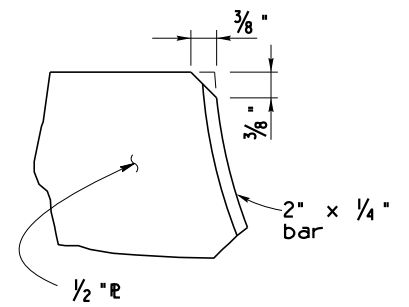

**DETAIL B**

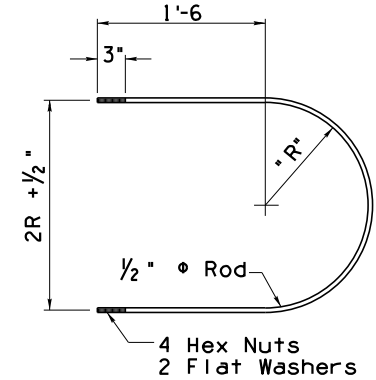

**SIGN SUPPORT U-BOLT**

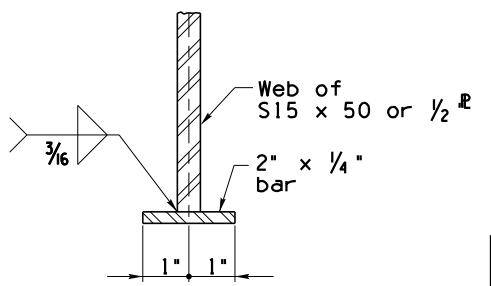

**SECTION C-C**

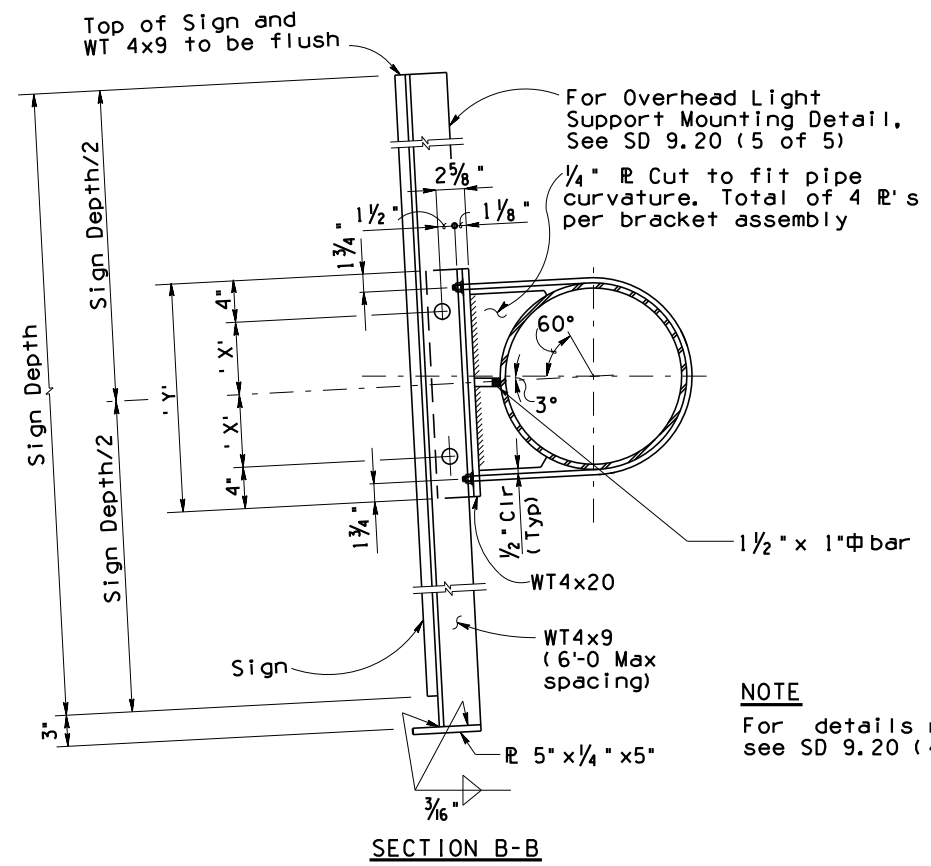

**SECTION B-B**

For Overhead Light Support Mounting Detail, See SD 9.20 (5 of 5)  
 1/4" R Cut to fit pipe curvature. Total of 4 R's per bracket assembly

**NOTE**  
 For details not shown see SD 9.20 (4 of 5)

Pipe O.D.	Distance	
	'X'	'Y'
12 3/4"	4 3/8"	1'-4 3/4"
16"	6"	1'-8"
20"	8"	2'-0"
22"	9"	2'-2"

Frame Type	Nominal Pipe Dia	R	L <sub>1</sub>	L <sub>2</sub>
1F	12"	6 3/8"	8 3/4"	8 3/8"
2F	16"	8"	7 7/8"	6 5/8"
3F	20"	10"	5 5/8"	4 5/8"
4F	22"	11"	4 5/8"	3 5/8"

STANDARDS ENGINEER  
**A. ALZUBI**  
 RECOMMENDED FOR APPROVAL  
 GROUP MANAGER  
**D. EBERHART**  
 APPROVED  
 STANDARDS COMMITTEE APPROVED FOR DISTRIBUTION 04/19 DATE

ARIZONA DEPARTMENT OF TRANSPORTATION  
 INFRASTRUCTURE DELIVERY AND OPERATIONS DIVISION  
 BRIDGE GROUP STANDARD DRAWING  
**VARIABLE MESSAGE SIGN  
 TUBULAR FRAME MOUNTING AND  
 SIGN BRACKET DETAILS**  
 DRAWING NO.  
**SD 9.50  
 (3 of 5)**

Note to Designer: The information presented in this Standard Drawing has been prepared in accordance with recognized engineering principles and is for general use. It should not be used for specific application without competent professional examination and verification of its suitability and applicability by a licensed professional engineer. Contents within the inner border line shall not be altered.

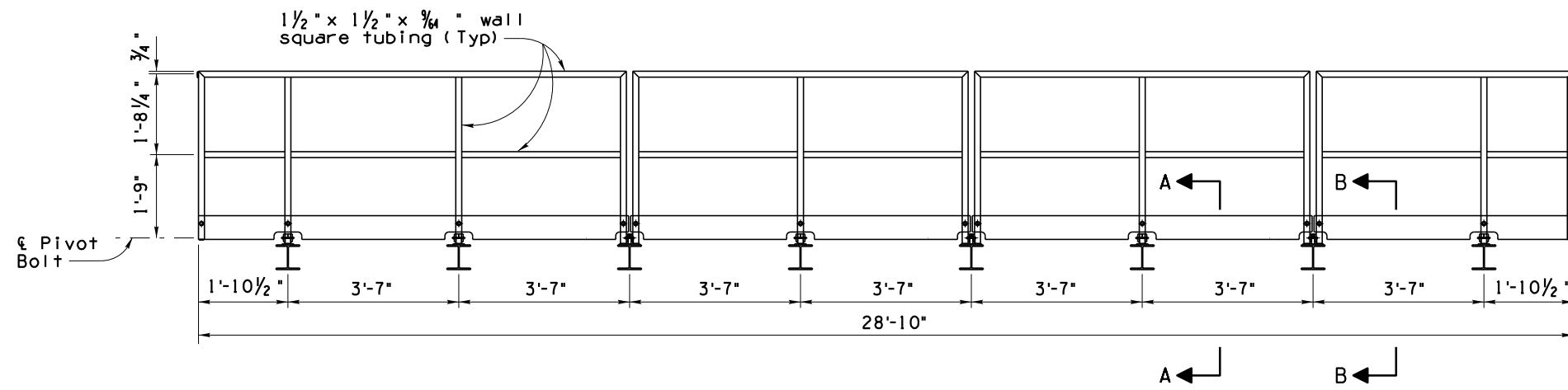

**HANDRAIL ELEVATION**  
Scale: 5/8" = 1'-0"

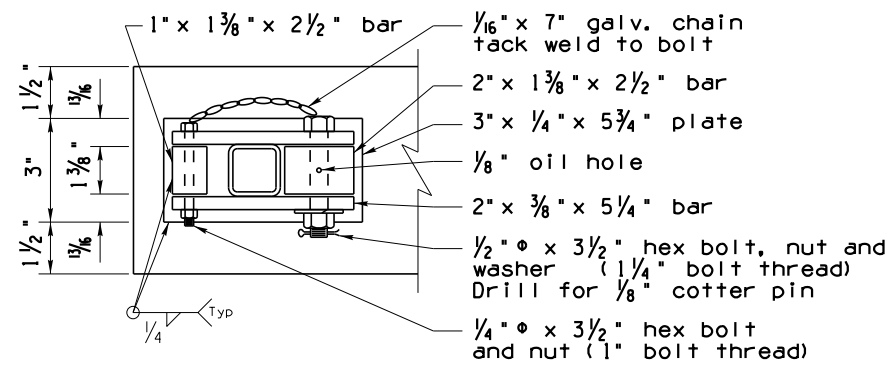

**SECTION C-C**  
(Single Post)

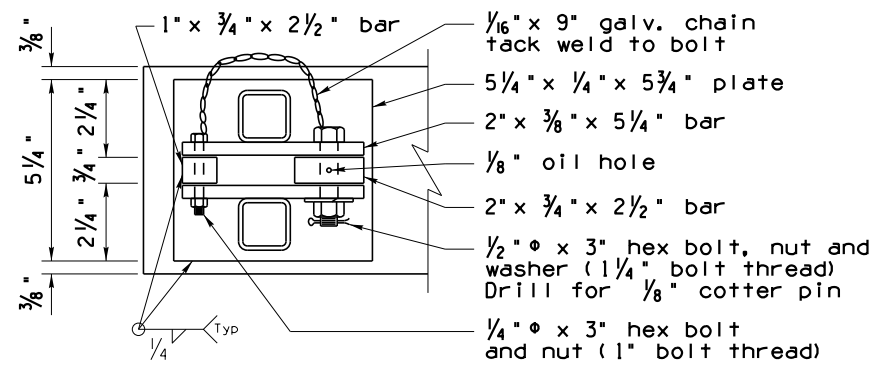

**SECTION E-E**  
(Dual Post)

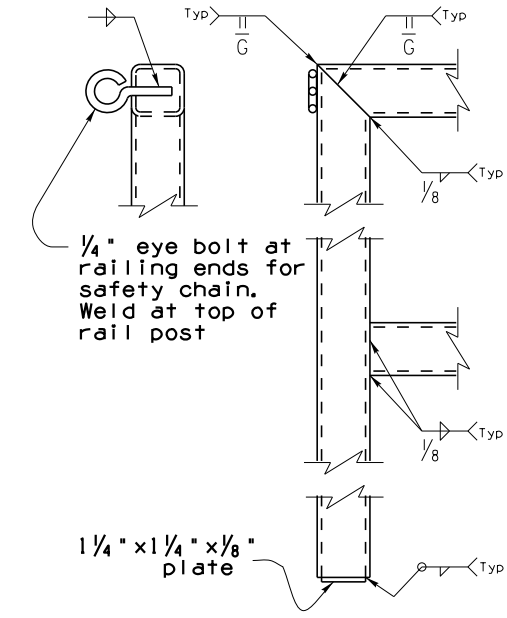

**HANDRAIL WELD DETAILS**

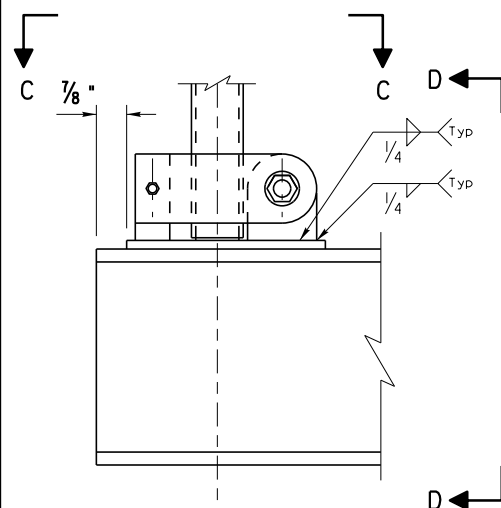

**SECTION A-A**  
(Single Post)

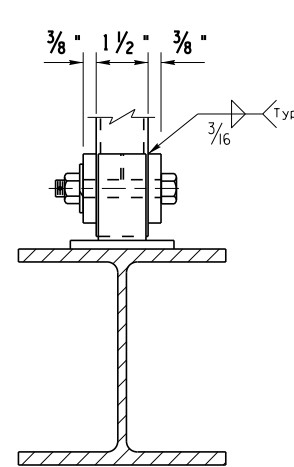

**SECTION D-D**  
(Single Post)

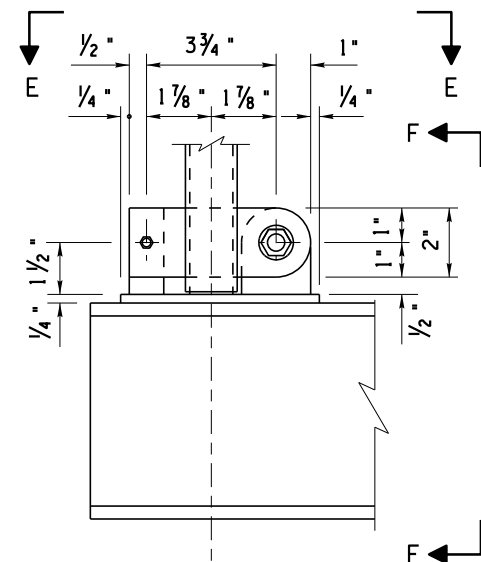

**SECTION B-B**  
(Dual Post)

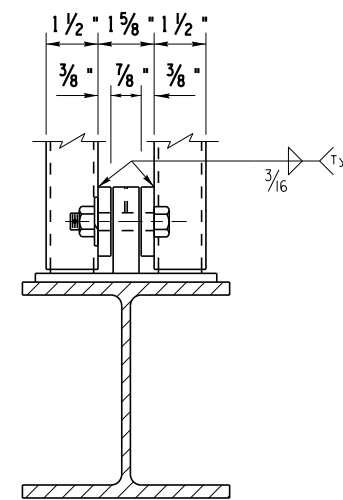

**SECTION F-F**  
(Dual Post)

**NOTES:**

- Handrail to be 1 1/2" x 1 1/2" x 3/16" square steel tubing weighing 2.70 plf
- Provide 5/8" holes for 1/2" pivot bolts, and 3/8" holes for 1/4" lock bolts

STANDARDS ENGINEER <b>A. ALZUBI</b>	ARIZONA DEPARTMENT OF TRANSPORTATION INFRASTRUCTURE DELIVERY AND OPERATIONS DIVISION BRIDGE GROUP STANDARD DRAWING
RECOMMENDED FOR APPROVAL GROUP MANAGER <b>D. EBERHART</b>	
APPROVED STANDARDS COMMITTEE APPROVED FOR DISTRIBUTION	VARIABLE MESSAGE SIGN CATWALK HANDRAIL DETAILS
DATE 04/19	DRAWING NO. SD 9.50 (4 of 5)

Note to Designer: The information presented in this Standard Drawing has been prepared in accordance with recognized engineering principles and is for general use. It should not be used for specific application without competent professional examination and verification of its suitability and applicability by a licensed professional engineer. Contents within the inner border line shall not be altered.

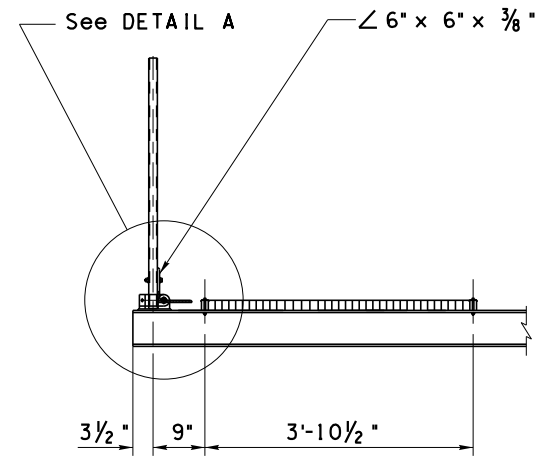

**PARTIAL SECTION OF VMS CATWALK**  
Scale: 3/4" = 1'-0"

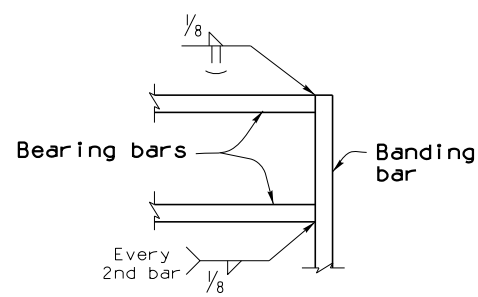

**DETAIL B**

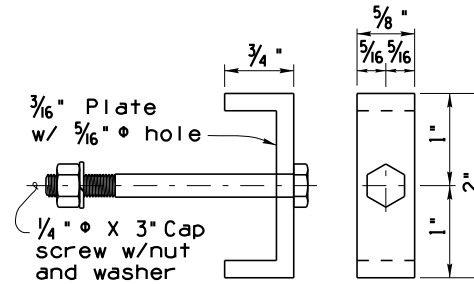

**GRATING CLIP**

**NOTES:**

Welded grating to be Irying Type IWA or approved equal. 1 3/4" x 3/16" bearing bars at 1 1/16" centers and cross bars at 4" centers.

All grating to have 1 3/4" x 3/16" banding bars at both ends. Weld bearing bars to banding bars with 1/8" fillet weld one side every second bar and as shown in detail B.

All grating to be straight and true after fabrication.

See table below for grating dimensions.

GRATING DIMENSIONS		
Grate No.	Length	Width
G-1	9' - 0"	3' - 11 1/16"
G-2	10' - 8 1/2"	3' - 11 1/16"
G-3	9' - 0"	3' - 11 1/16"

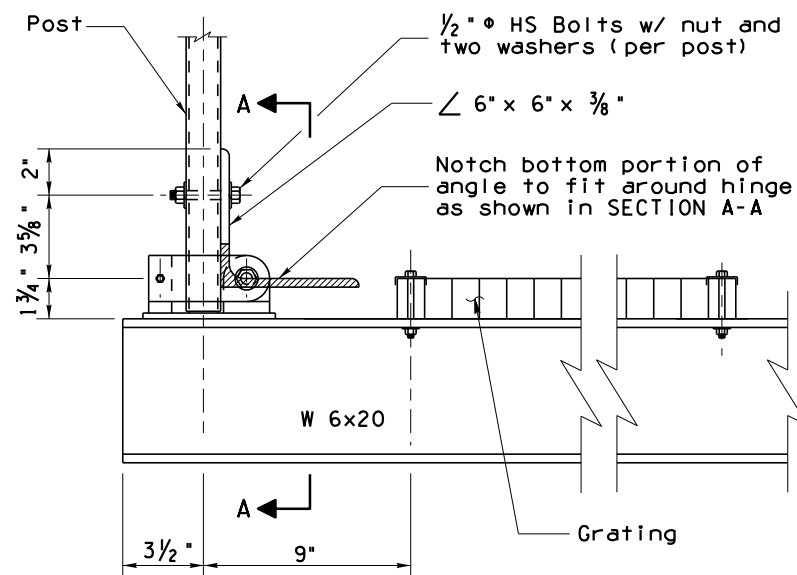

**DETAIL A**

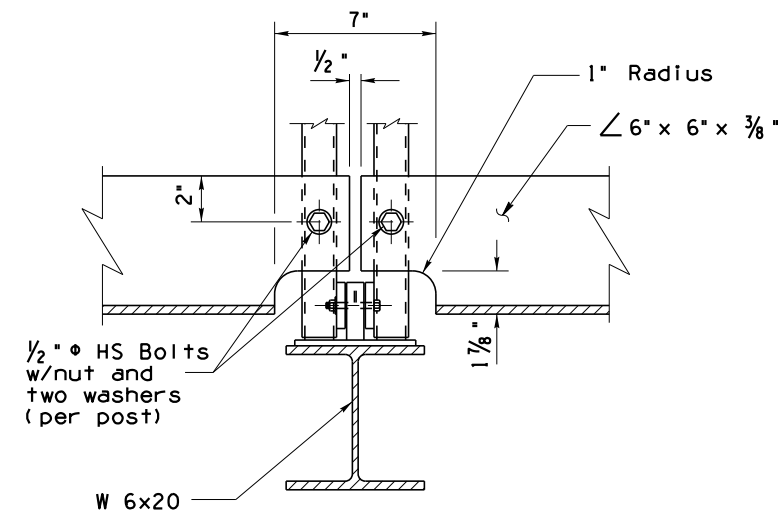

**SECTION A-A (Dual Posts)**

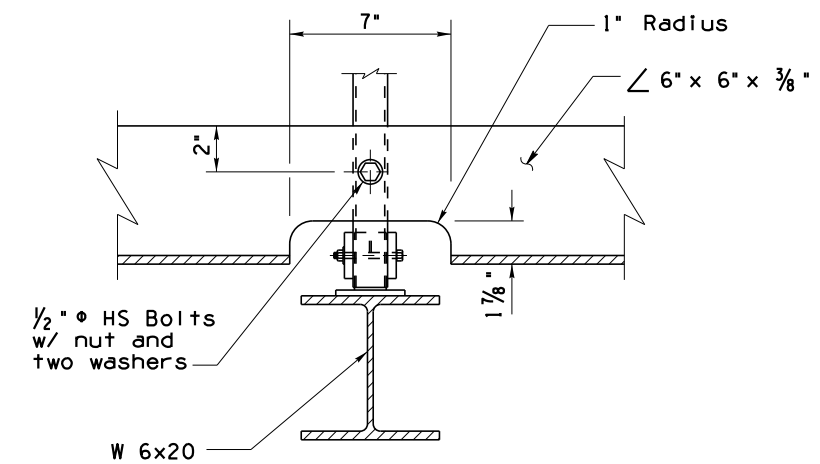

**SECTION A-A (Single Post)**

STANDARDS ENGINEER <b>A. ALZUBI</b>	ARIZONA DEPARTMENT OF TRANSPORTATION INFRASTRUCTURE DELIVERY AND OPERATIONS DIVISION BRIDGE GROUP STANDARD DRAWING	
RECOMMENDED FOR APPROVAL GROUP MANAGER <b>D. EBERHART</b>	VARIABLE MESSAGE SIGN CATWALK MISCELLANEOUS DETAILS	DRAWING NO. SD 9.50 (5 of 5)
APPROVED STANDARDS COMMITTEE APPROVED FOR DISTRIBUTION	DATE 04/19	