

NOTE:

Curb and bridge deck reinforcement not shown for clarity. See SD 1.06(4 of 4) for curb reinforcing.

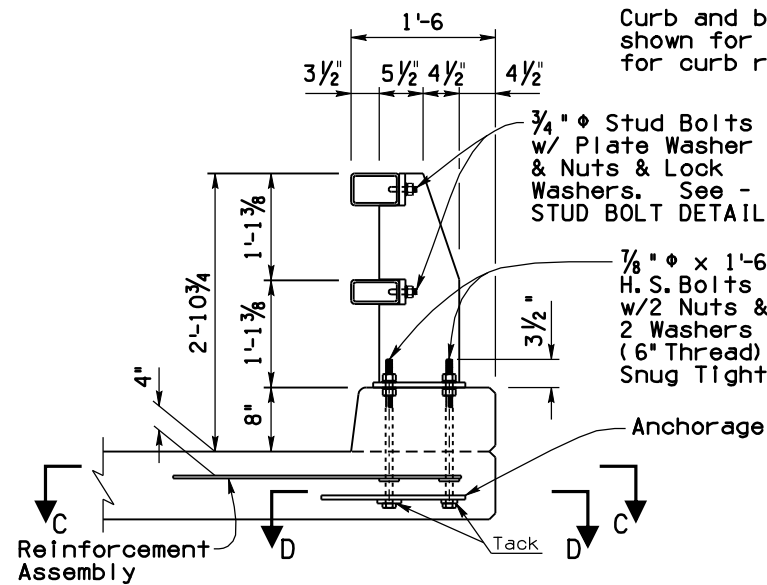

SECTION A-A

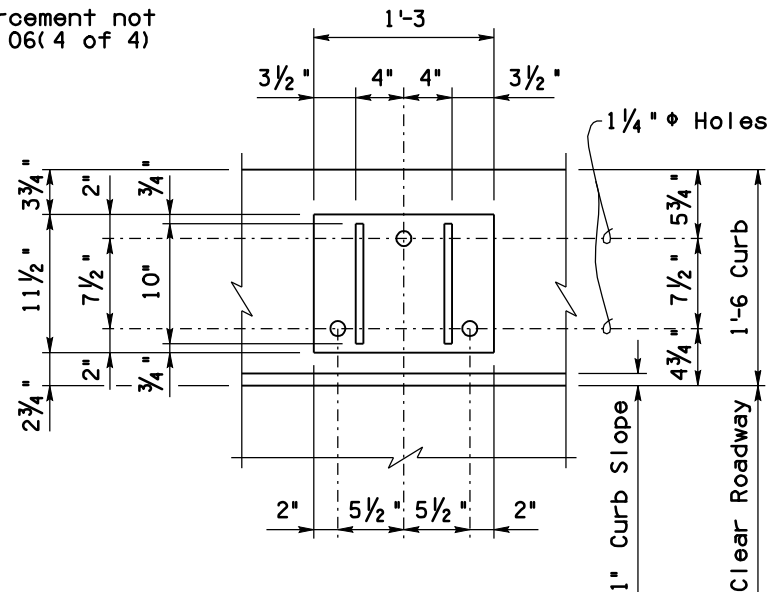

SECTION B-B

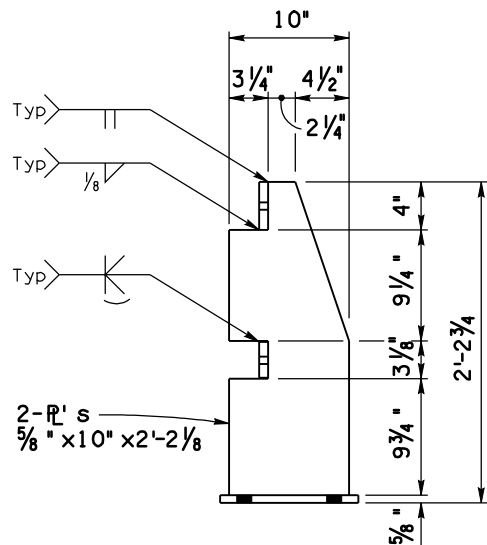

POST DETAIL
(Side View)

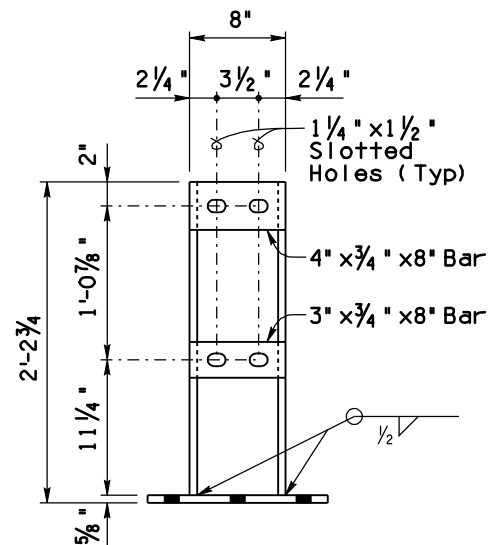

POST DETAIL
(Elevation)

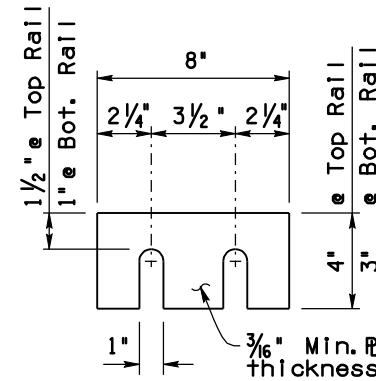

SHIM PLATE DETAIL

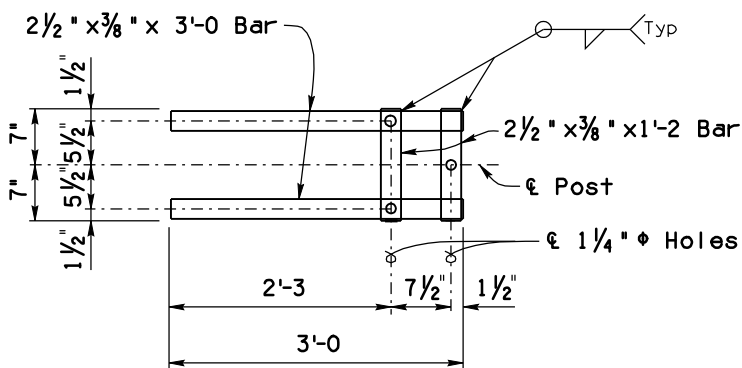

SECTION C-C
(Reinforcement Assembly)

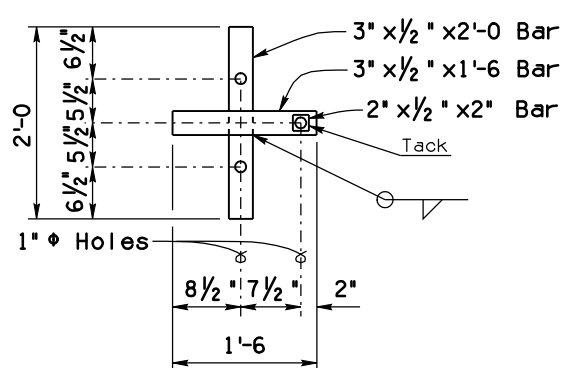

SECTION D-D
(Anchorage)

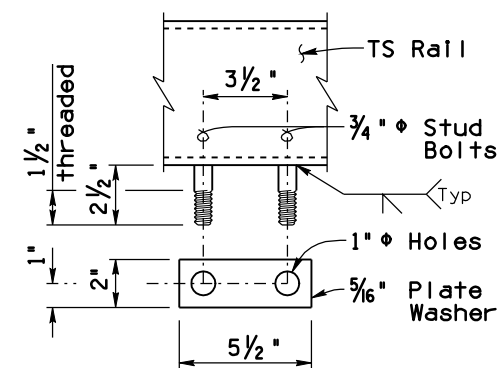

STUD BOLT DETAIL

INSTALLATION NOTES:

- Venting and pick-up holes in rails and sleeves shall be shown on fabricator's shop plans.
- Anchor bolts may be tack welded to anchorage. (Shop or field.)
- All rough edges on posts and rails shall be ground smooth.
- Post base (R's) shall be flat after fabrication.
- Rails shall not be field spliced.
- Railing posts shall be in place and in proper alignment prior to placement of curb concrete.
- Shim plates shall be provided as necessary to provide contact of TS rails to posts. Bolted connections shall be snug tight.
- After installation of rail, the exposed rail bolt threads shall be painted with two coats of zinc rich paint conforming to the requirements of ADOT Standard Specifications for Road and Bridge Construction.
- Rail expansion splices shall be located in the railing panel which passes over the bridge expansion joint. See Bridge Drawings for expansion joint locations.
- Either top or bottom rail in standard splice terminal section may be the longer rail.
- In rehabilitation work, railing that cannot feasibly be made continuous over a minimum of two posts shall be provided with a double-bolted splice.
- Not more than one splice shall be permitted per side of post except at expansion splices.

Note to Designer: The information presented in this Standard Drawing has been prepared in accordance with recognized engineering principles and is for general use. It should not be used for specific application without competent professional examination and verification of its suitability and applicability by a licensed professional engineer. Contents within the inner border line shall not be altered.

06/12

PRIOR DISTRIBUTION DATE

STANDARDS ENGINEER
A. M. ALZUBI
 RECOMMENDED FOR APPROVAL
 GROUP MANAGER
D. L. EBERHART
 APPROVED
 STANDARDS COMMITTEE APPROVED FOR DISTRIBUTION

ARIZONA DEPARTMENT OF TRANSPORTATION
 INFRASTRUCTURE DELIVERY AND OPERATIONS DIVISION
 BRIDGE GROUP STANDARD DRAWING

TWO TUBE BRIDGE RAIL

DRAWING NO.

SD 1.06

Sheet 2 of 4