

Note to Designer: The information presented in this Standard Drawing has been prepared in accordance with recognized engineering principles and is for general use. It should not be used for specific application without competent professional examination and verification of its suitability and applicability by a licensed professional engineer. Contents within the inner border line shall not be altered.

PRIOR DISTRIBUTION DATE 06/12

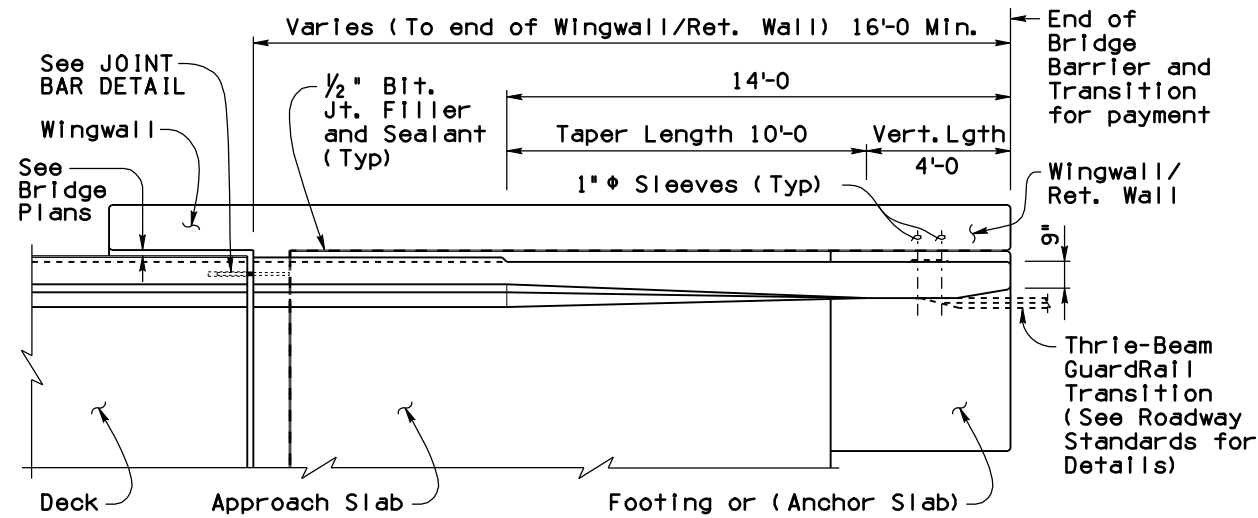

PLAN

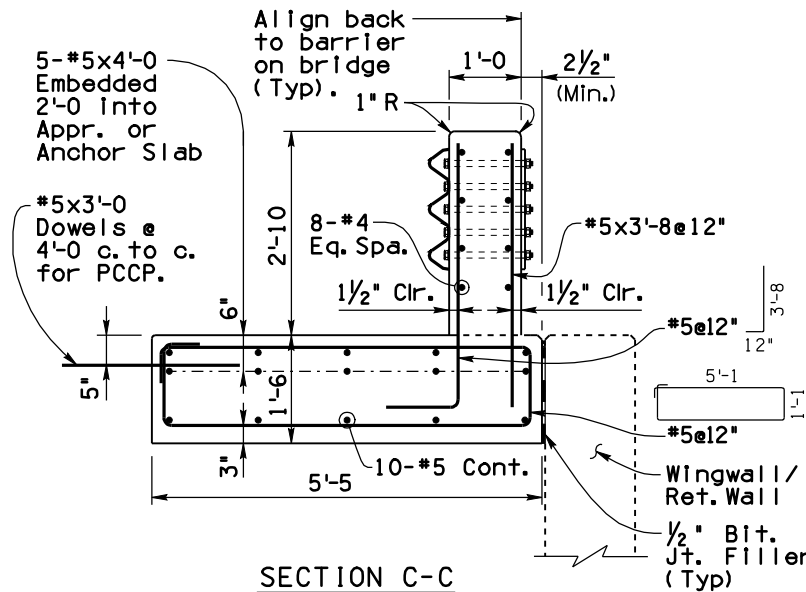

SECTION C-C

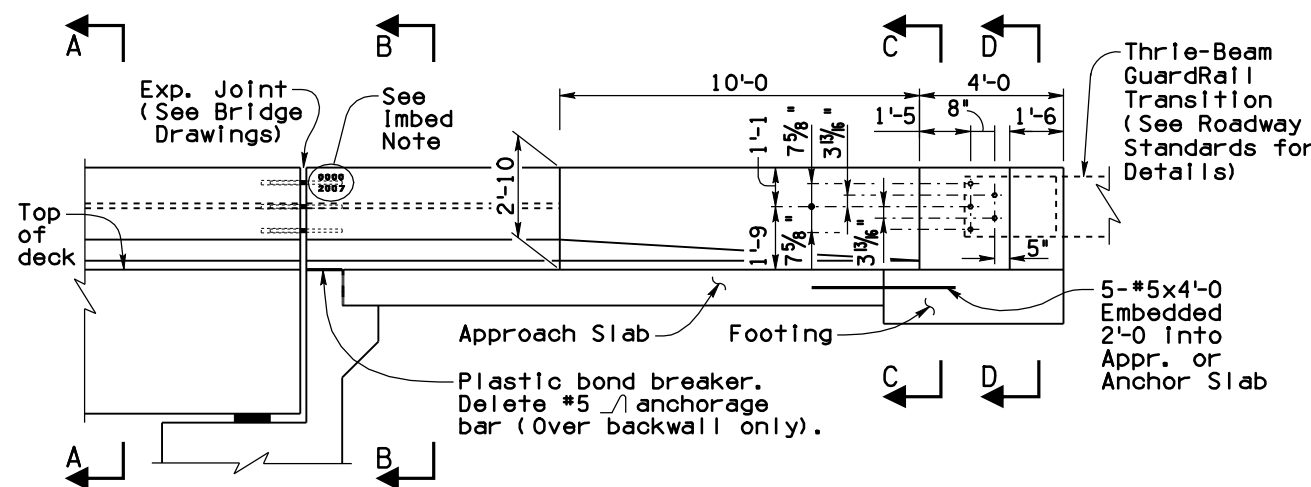

ELEVATION

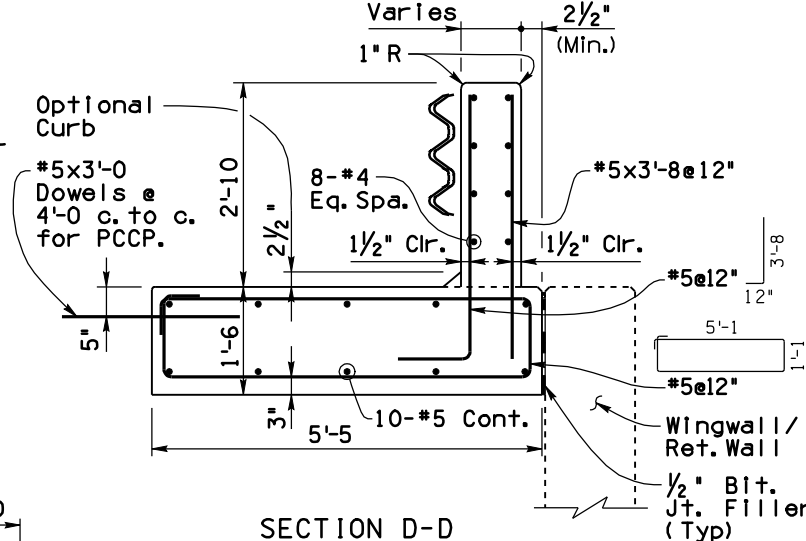

SECTION D-D

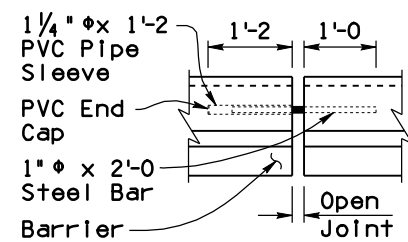

JOINT BAR DETAIL

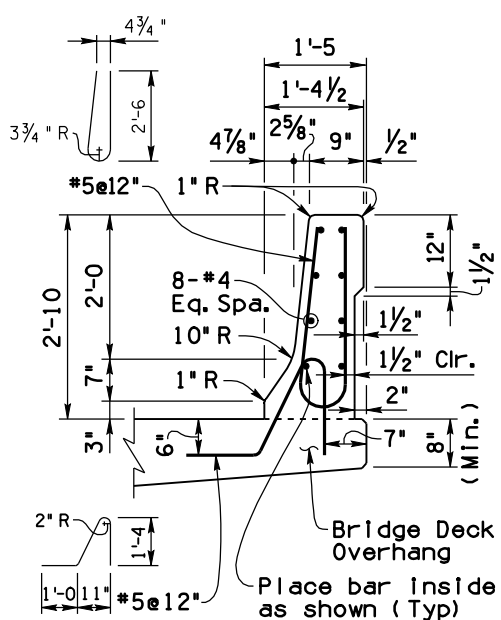

SECTION A-A

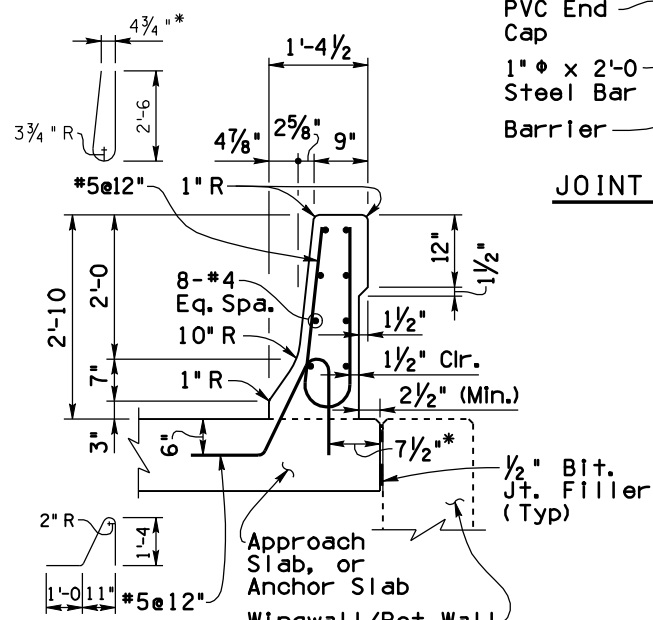

SECTION B-B

\*Varies at taper length

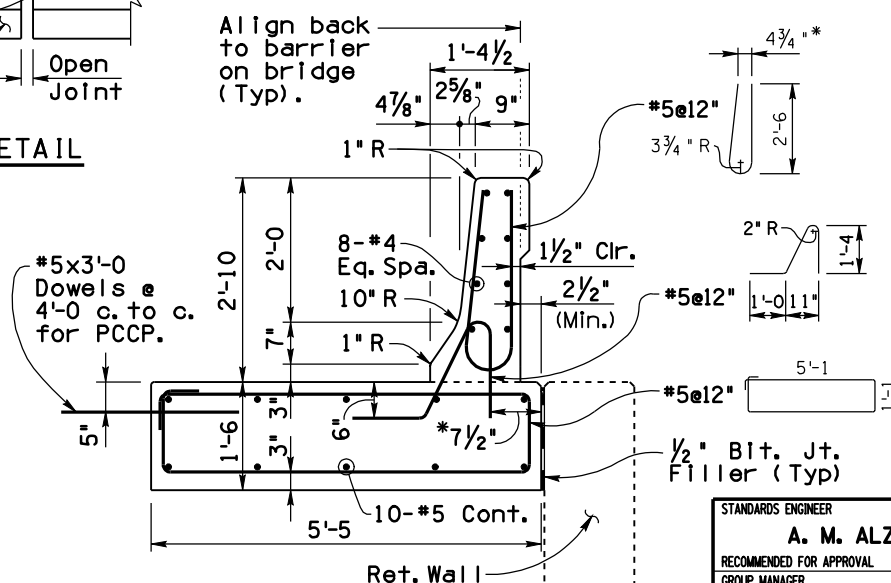

SECTION  
Continuous Barrier With Footing

**GENERAL NOTES:**

Construction Specification - Arizona Department of Transportation Standard Specifications for Road and Bridge Construction, latest Edition.

Design Specifications - AASHTO LRFD Bridge Design Specifications, 7th Edition 2014.

This barrier has been successfully crash tested and is structurally evaluated as meeting the requirements of NCHRP Report 350 Test Level 4.

All Concrete shall be Class "S" (f'c = 4000 psi).

Reinforcing steel shall conform to ASTM Specification A615. All reinforcing shall be furnished as Grade 60. All reinforcing shall be epoxy coated at locations above EL.4000 ft.

All bends and hooks shall meet the requirements of AASHTO LRFD Article 5.10. All bend dimensions for reinforcing steel shall be out-to-out of bars. All placement dimensions for reinforcing steel shall be to center of bars unless noted otherwise.

All reinforcing steel shall have 2 inch clear cover unless noted otherwise.

Concrete barriers on continuous superstructures shall have 1/2 inch bituminous joint filler in open joints over piers. See bridge drawings for details.

Imbed 1/2 inch, Bridge Number and Year Built, using 1 1/2 inch w x 2 inch h number impressions in concrete, located as shown at the approach end of the outside lane.

Anchorage bars are included in the pay item for barrier (Item No. 6011140).

Omit bridge barrier transition when concrete barrier is continuous beyond bridge.

Dimensions shall not be scaled from drawings.

Item No. 6011140 F-SHAPE BRIDGE CONCRETE BARRIER AND TRANSITION (34")  
Measure: Linear Foot

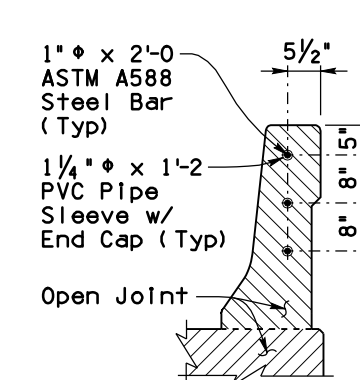

OPEN JOINT DETAIL  
At Expansion Joints

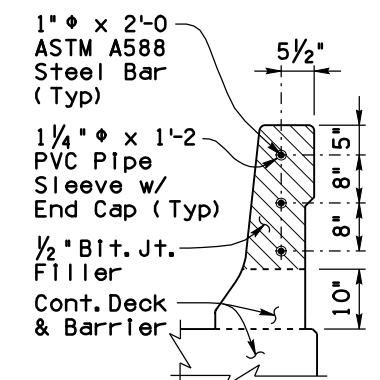

OPEN JOINT DETAIL  
Over Continuous Piers

STANDARDS ENGINEER	A. M. ALZUBI
RECOMMENDED FOR APPROVAL	D. L. EBERHART
GROUP MANAGER	
APPROVED	
STANDARDS COMMITTEE APPROVED FOR DISTRIBUTION	12/17 DATE

ARIZONA DEPARTMENT OF TRANSPORTATION INFRASTRUCTURE DELIVERY AND OPERATIONS DIVISION BRIDGE GROUP STANDARD DRAWING	
F-SHAPE BRIDGE CONCRETE BARRIER AND TRANSITION (34")	DRAWING NO. SD 1.01