

SECTION 14: JOINTS AND BEARINGS

TABLE OF CONTENTS

14.1 SCOPE	2
14.4 MOVEMENTS AND LOADS	2
14.4.1 General	2
14.4.2 Design Requirements	2
14.4.2.1 Elastomeric Pads and Steel Reinforced Elastomeric Bearings	5
14.5 BRIDGE JOINTS	5
14.5.1 Requirements	5
14.5.1.2 Structural Design	5
14.5.3 Design Requirements	6
14.5.3.1 Movements During Construction	6
14.5.3.3 Protection	7
14.5.3.5 Armor	7
14.5.5 Installation	7
14.5.5.3 Field Splices	7
14.5.6 Considerations for Specific Joint Types	7
14.5.6.6 Compression and Cellular Seals	8
14.5.6.7 Sheet and Strip Seals	9
14.5.6.9 Modular Bridge Joint Systems (MBJS)	10
14.6 REQUIREMENTS FOR BEARINGS	10
14.6.1 General	10
14.7 SPECIAL DESIGN PROVISIONS FOR BEARINGS	11
14.7.1 Metal Rocker and Roller Bearings	11
14.7.2 PTFE Sliding Surfaces	11
14.7.5 Steel-Reinforced Elastomeric Bearings – Method B	14
14.7.5.1 General	14
14.7.5.2 Material Properties	15
14.7.6 Elastomeric Pads and Steel-Reinforced Elastomeric Bearings - Method A	16
14.7.6.3 Design Requirements	17
14.7.6.3.5 Rotation	17
14.7.9 Guides and Restraints	18
14.7.9.1 General	18

14.1 SCOPE

This section contains guidelines to supplement provisions of Section 14 of the AASHTO LRFD Bridge Design Specifications for the design and selection of bridge expansion joints, bearings and restraining devices.

It is ADOT Bridge Group's policy to promote the design of bridges with minimal number of joints. Bridge joints account for a large portion of bridge inspectors' repair recommendations and maintenance personnel complaints; reducing the number of joints would lower life cycle costs.

14.4 MOVEMENTS AND LOADS

14.4.1 General

Provisions shall be made in the design of structures to resist induced stresses or to provide for movements resulting from variations in temperature, shortening of structure length due to creep, shrinkage, and prestressing or a combination of thereof. Accommodation of thermal and shortening movements will entail consideration of deck expansion joints, bearing systems, restraining devices and the interaction of these three items.

The main purpose of deck joints is to seal the joint opening to obtain a watertight joint while allowing for vertical, horizontal and rotational movement. The bearings are required to transmit the vertical and lateral loads from the superstructure to the substructure and to allow for movement in the unrestrained directions. Restraining devices are required to limit the displacement in the restrained directions. Improper design or construction of bearings or restrainers could adversely affect the movement of the structure.

The calculated displacements used in determining the required displacement (i.e. the difference between the widest and the narrowest opening of a joint) shall be the sum of 1.2 times the movements caused by temperature changes and 1.0 times the shortening movement caused by creep and shrinkage.

14.4.2 Design Requirements

Temperature Movement:

Temperature ranges shall be as specified in the following table which replaces AASHTO LRFD Table 3.12.2.1-1 for Procedure A.

Elevation (ft)	Mean (°F)	Concrete		Steel	
		T _{min} (°F)	T _{max} (°F)	T _{min} (°F)	T _{max} (°F)
Up to 3000	75	35	105	15	135
3000 - 6000	60	20	90	0	120
Over 6000	50	5	85	-30	120

The differential movement in inches, ΔL , due to temperature difference for joints and elastomeric bearings shall be calculated as specified below:

Joints: $\Delta L = \alpha L (T_{\max} - T_{\min})$

Elastomeric Bearings: $\Delta L = 0.65\alpha L (T_{\max} - T_{\min})$

where:

Steel: $\alpha = 6.5 \times 10^{-6}$, coefficient of thermal expansion, inch / inch / °F

Concrete: $\alpha = 6.0 \times 10^{-6}$, coefficient of thermal expansion, inch / inch / °F

L = span length, inch

Unless a more precise method of measuring the temperature of the main superstructure members is used, the setting temperature of the bridge or any component thereof shall be taken as the actual air temperature averaged over the 24-hour period immediately preceding the setting event. The setting temperature is used in installing expansion bearings and deck joints.

Shortening Movement:

Displacement of concrete structures must account for the shortening due to creep, shrinkage, and prestressing force. For concrete structures, change in length shall be calculated as specified below.

For conventionally reinforced concrete members the anticipated long-term shortening due to shrinkage shall be:

Joints: 0.36 inch per 100 feet.

Bearings: 0.60 inch per 100 feet

For precast prestressed concrete members, the anticipated long term shortening including creep and shrinkage shall be:

Joints: 0.25 inches per 100 feet.

Bearings: 0.60 inches per 100 feet.

For cast-in-place post-tensioned concrete box girder bridges, the anticipated shortening including creep for deck joints shall be 0.50 inch per 100 feet.

For cast-in-place post-tensioned concrete box girder bridges, the effects of elastic shortening due to prestressing shall be considered in determining the movement for the bearings. The anticipated total shortening including elastic shortening, creep, and shrinkage for bearings shall be 1.20 inch per 100 feet.

For bridges where the construction schedule is short or delayed past a reasonable time, such as a winter shutdown, design engineers may want to estimate shortening factors using the graph shown below, which is reproduced for convenience, from Caltrans Memo to Designers 7-1, Attachment 1, June 1994, Technical Publications, Section 7-Bearing and Expansion Devices, September 2004.

Figure 1 – Prestress Shortening Assuming Total Long Term Shortening 0.10 ft / 100 ft

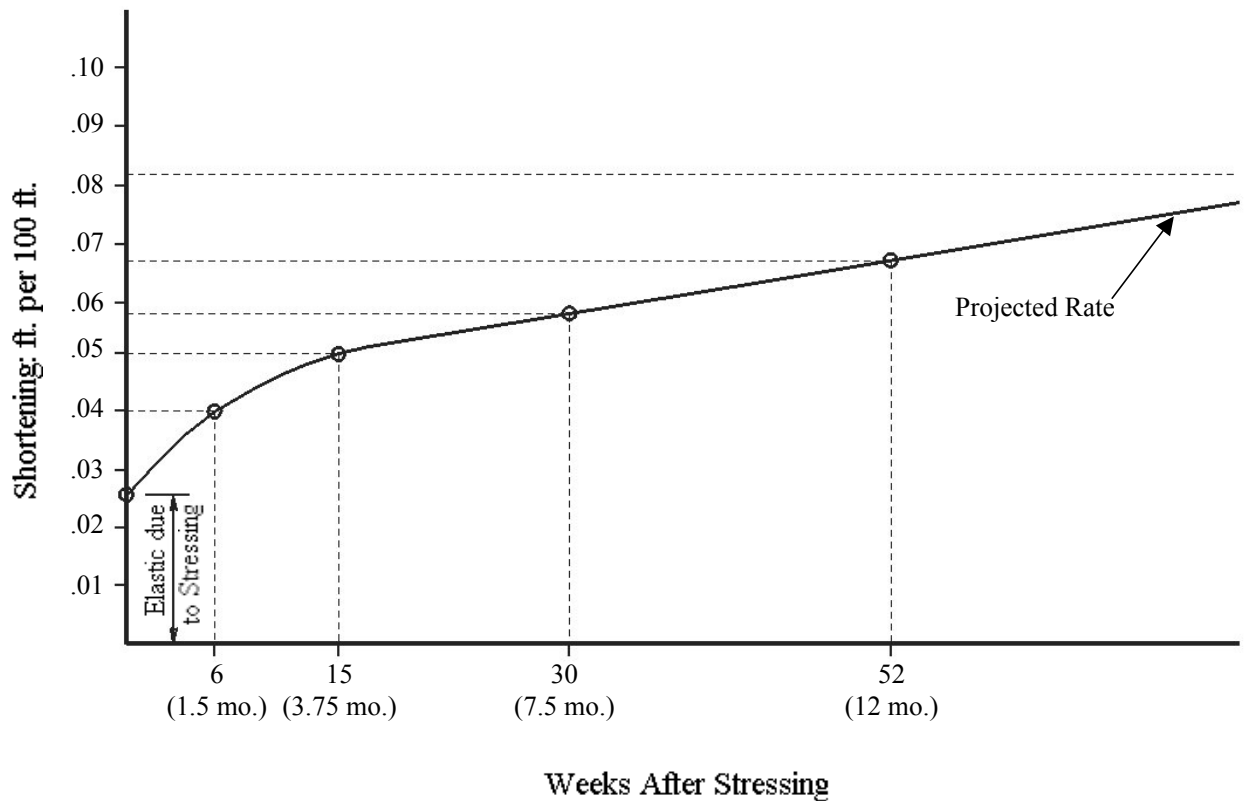

In addition, the effects of bridge skew, curvature, and neutral axis location shall be considered. The neutral axis of the girder and the neutral axis of the bearing seldom coincide resulting in the rotation of the girder inducing either additional horizontal displacement or forces at the joint or at bearing level. Bearing design should include the effects of the additional displacement or force.

14.4.2.1 Elastomeric Pads and Steel Reinforced Elastomeric Bearings

The maximum unfactored service rotation due to total load, which include dead load and live load plus impact, shall be the sum of the rotations caused by applicable unfactored loads. Additionally, a 0.005 radians allowance for uncertainties in rotation shall be included unless an approved quality control plan justifies a smaller value. These uncertainties include allowances for fabrication and installation tolerances.

14.5 BRIDGE JOINTS

14.5.1 Requirements

14.5.1.2 Structural Design

The design and performance of the deck joints are critical to the bearing performance and future maintenance of the structure. The selection of the joint type shall be based on the displacement requirement of the structure.

The displacement for joints for steel structures shall be based primarily on the thermal expansion and contraction characteristics of the superstructure. For concrete structures, the effects of shortening due to creep, shrinkage, and prestressing shall also be included in determining the displacement. Displacements shall be based on temperature variations as measured from the assumed mean temperature.

Published displacements from a manufacturer are usually based on the difference between the maximum and minimum openings without consideration to the required minimum installation width. In determining the displacement, consideration must be given to the installation width required to install the seal element.

Other factors to be considered in determining the required displacement include consideration of the effects of any skew, and anticipated settlement and rotations due to live loads and dead loads, where appropriate.

Displacement calculations should account for the following items:

- The type of anchorage system to be used.
- The method of joint termination at the ends.
- The method of running joints through barriers, sidewalks and medians.
- Physical limitation on size of joints.
- Susceptibility of joint to leakage.

Possible interference with post-tensioning anchorages.

Selection of appropriate modular proprietary systems that meet design requirements.

Forces applied to the surrounding concrete by the joint.

Specifying the use of a continuous seal element.

Long term maintenance and life-cycle analysis.

For skewed bridges, the transverse movement along the joint shall be the calculated displacement along the bridge centerline times the sine of the skew angle. The longitudinal displacement normal to the joint shall be the calculated displacement along the bridge centerline times the cosine of the skew angle. A skew angle is defined as the angle subtended between the normal to the bridge centerline and the alignment of the bridge abutment or piers.

For a curved superstructure that is laterally unrestrained by guided bearings or shear keys, the direction of longitudinal movement at a bearing joint may be assumed to be parallel to the chord of the deck centerline.

The rolling resistance of rocker and rollers, the shear resistance of elastomeric bearings, or the frictional resistance of bearing sliding surfaces will oppose movement. In addition, the rigidity of abutments and the relative flexibility of piers of various heights and foundation types will affect the magnitude of the movement of the bearing and the forces opposing the movement. These forces should be considered during the substructure design.

14.5.3 Design Requirements

14.5.3.1 Movements During Construction

Where practicable, construction staging should be used to delay construction of abutment and piers located in or adjacent to embankments until the embankments have been placed and consolidated. Otherwise, deck joints should be sized to accommodate the probable abutment and pier movements resulting from embankment consolidation after their construction.

Closure pours in concrete structures may be used to minimize the effect of prestress-induced shortening on the width of seals and the size of bearings and to ensure proper placement of the joint and consolidation of the surrounding concrete.

For concrete superstructures, consideration shall be given to the opening of joints due to creep and shrinkage, which may require initial minimum openings of less than 1-inch.

14.5.3.3 Protection

Joints in concrete decks should be armored with steel shapes. Such armor shall be recessed below roadway surfaces and be protected from snowplows. Snowplow protection for deck joint armor and joint seals may consist of:

Concrete buffer strips 12 to 18 inches wide with joint armor recessed 1/4 to 3/8 inches below the surface of such strips.

Tapered steel ribs protruding up to 1/2-inch above roadway surfaces can be used to lift the plow blades as they pass over the joints.

Additional precautions to prevent damage by snowplows should be considered where the skew of the joints coincides with the skew of the plow blades, typically 30 to 35 degrees. Details for snowplow protection shall be coordinated with ADOT Bridge Group and the District Construction Office.

14.5.3.5 Armor

Joint-edge armor embedded in concrete should have 1/2-inch diameter vertical vent holes spaced no more than 9 inch centers along the length of the armor. These vent holes are necessary to expel entrapped air and facilitate the attainment of a consolidated concrete support under the joint edge armor.

14.5.5 Installation

14.5.5.3 Field Splices

Joint designs shall include details for transverse field splices for staged construction and for joints longer than 60 feet. Where practicable, splices should be located at the crown, cross slope break point, or along the traffic lane line. Details of splices should be selected to maximize fatigue life. The contract documents shall require that permanent seals not be placed until after joint installation has been completed. Where practicable, only those seals that can be installed in one continuous piece should be used. Where field splicing is unavoidable, splices should be vulcanized. Splices should not be located within a lane or gutter area.

14.5.6 Considerations for Specific Joint Types

Available joint types are: compression seals, strip seals, and modular joints. Compression seal joints and strip seal joints are generic and should be detailed on the plans by referencing the appropriate Structure Detail (SD) Drawings ([click here](#)). Modular joints are proprietary items and require that the design engineer specify acceptance criteria on the plans and reference ADOT Standard Specifications for Road and Bridge Construction for additional details.

The following issues shall be addressed in the detailing or in the specifications special provisions:

Secondary pour, block-out dimensions, and additional reinforcement requirements should be included in the block-out details.

End treatment in barriers or curbs, including details or explanation to accommodate potential proprietary systems. This should include the need for cover plates and method of termination of the joint in sidewalks and separation barriers.

Consideration to traffic control in determining section pattern lengths.

Displacements.

Assumed temperature and opening at time of installation with temperature correction table showing the joint opening at various temperatures.

Actual horizontal length of joint measured from inside of barrier face to inside of barrier face corrected for skew and super elevation.

The method of seal termination in barriers, sidewalks and raised medians. In general the seal should be turned up a minimum of 6 inches or 2 inches above the high water depth at the curb to keep the roadway water in the roadway drainage collection system. To better seal the joint, and to minimize construction errors, the seal should be turned up at both the low and high sides.

The special provisions shall specify that the method of measurement is linear foot from face to face of barrier or face of parapet, including sidewalk width.

For modular joints, the acceptance criteria, steel edge beam material, and the requirements for a trained manufacturer's representative shall be specified in both the special provisions and the plans.

For bridges located in non-corrosive environments, the exposed steel armor surfaces shall be painted for ASTM A36 steel or left unpainted for ASTM A588 steel. For bridges subjected to de-icing salts and for bridges located above 4,000 feet, the armor should be galvanized. The need for galvanizing shall be specified on the plans and in the special provisions.

14.5.6.6 Compression and Cellular Seals

Compression seal joints shall conform to the details shown in SD 3.01 ([click here](#)). Proprietary alternates to the details shown in the SD drawing will not be allowed. The compression seal element should have a shape factor of 1:1 (width to height) to minimize sidewall pressure. The size of the compression seal shall be specified on the plans.

For these types of joints, the effective displacement range is up to 2.5 inches. Advantages for these joints include their comparatively lower cost, proven performance and acceptance for use on pedestrian walkways without the need for cover plates.

These joints are not suitable for high skews or horizontally curved bridges. For skewed bridges, the transverse movement should be less than 20 percent of the nominal seal dimension. This longitudinal movement should be less than the specified movement rating for the seal. The maximum allowed skew for use of a compression seal is 45 degrees with 30 degrees being the preferred limit.

If not properly sized, compression and cellular seals joints may be difficult to maintain. For instance, when the seals are too small for the displacement they can pull away from the angle iron and either drop down or come out of the joint. On the other hand, if the seals are too large they will bulge out of the joint and could be damaged by traffic.

Compression seals shall be supplied without splicing. Where the length of the deck joint is less than 60 feet, the deck joint shall be supplied in one piece and the seal may be factory installed. Where phase construction is required or where the deck joint is longer than 60 feet, the armor may be supplied in pieces and spliced in the field. However, the seal shall be installed in one piece. Since the design engineer has no prior knowledge of the manner the seal will be supplied, consideration must be made for the minimum installation width of the seal. Typically the seal can be installed if the opening is as low as 50% of its nominal dimension. As a general practice, the joint opening is set at the mean temperature for 60% of the required width. This will allow easy installation at the mean temperatures but still allow for installation at higher temperatures.

The following table, which lists contract bid item numbers, joint description, and units of measurements, is included for convenience:

Bid Item	Description	Measurement
6011346	Deck Joint Assembly (2x2 compression seal)	LF
6011347	Deck Joint Assembly (3x3 compression seal)	LF
6011348	Deck Joint Assembly (4x4 compression seal)	LF
6011349	Deck Joint Assembly (5x5 compression seal)	LF

14.5.6.7 Sheet and Strip Seals

Strip seals shall conform to the details shown in SD 3.02 ([click here](#)). Alternative details, other than those shown in the drawing, which are proprietary, will not be allowed.

For this type of joint, effective displacement range may be up to 4 inches. This type of joint is recommended when the displacement is beyond the capacity of compression seals and for large skews. Strip seal joints will require cover plates for pedestrian walkways.

The seals shall be supplied continuous in one piece. Since the seal must be installed after the armor is set in concrete, a minimum installation opening must be provided. In general, a

minimum opening of 1.75 inches is preferred for easy installation but the seal can be installed in openings as small as 1.5 inches. The opening at the mean temperature should be set to 1.75 inches whenever possible.

The following table, which lists the contract bid item number, joint description, and unit of measurement, is included for convenience:

Bid Item	Description	Measurement
6011345	Deck Joint Assembly (strip seal joint)	LF

14.5.6.9 Modular Bridge Joint Systems (MBJS)

Modular joint systems are proprietary with effective displacement ranging from 4 inches up to 30 inches. Modular joints are the best choice for displacements over 4 inches; however, these joints should be avoided whenever possible due to their high initial and lifecycle costs.

MBJS shall satisfy all requirements specified in the specifications special provisions and ADOT Standard Specifications for Road and Bridge Construction. Information concerning specific design parameters and installation details of modular joints should be obtained from literature supplied by the manufacturer of the system. It is the responsibility of the design engineer to review the literature of the proprietary joint and related manufacturer's specifications to ensure that the selected joint types are properly specified and compatible with the design requirements.

The following table, which lists the contract bid item number, joint description, and unit of measurement, is included for convenience:

Bid Item	Description	Measurement
6011355	Deck Joint Assembly (Modular, Movement Rating)	LF

14.6 REQUIREMENTS FOR BEARINGS

14.6.1 General

Unlike joints, where the opening can be adjusted if the ambient temperature at the time of construction is different than the assumed mean temperature, bearings must be designed to be installed at temperatures other than the mean temperature. For this reason, the displacement should be based on 65% of the full temperature range and not the rise or fall from a mean temperature.

Calculation of the displacement shall include thermal movement and anticipated superstructure shortening due to creep, shrinkage and prestressing force, where applicable. For cast-in-place post-tensioned concrete box girder bridges, both the elastic and long term prestress shortening effects shall be included.

Bearing types include neoprene strips, elastomeric bearing pads, sliding elastomeric bearings, steel bearings and high-load multi-rotational bearings, such as pot; disc or spherical bearings.

Neoprene strips, elastomeric bearing pads, and steel bearings are generic and shall be detailed in the plans. The special provisions shall include performance specifications for these bearing types.

High-load multi-rotational bearings are proprietary bearings. When using these bearings, the design engineer shall include a bearing schedule in the plans, review the applicability of the manufacturer's specifications, and the adequacy of the manufacturer's design.

All bearing types except elastomeric bearing pads shall be designed for dynamic impact allowance, IM. For all limit states, IM shall be 75%; refer to AASHTO LRFD Article 3.6.2.

For bearings with sliding surfaces, an initial offset of the top sliding surface from the centerline of bearing should be calculated and shown in the plans. The calculated offset is the sum of the superstructure displacement due to creep, shrinkage, and prestressing force, where applicable. The objective is to align the top and bottom sliding surfaces with the centerline of the bearing after all losses have occurred.

14.7 SPECIAL DESIGN PROVISIONS FOR BEARINGS

14.7.1 Metal Rocker and Roller Bearings

Steel bearings may consist of metal rockers or of fixed or expansion assemblies, the mechanical properties of which shall conform to the requirements specified in AASHTO LRFD Bridge Design Specifications, Section 6.

Steel bearings are not a preferred bearing type and their use should normally be limited to situations where new bearings are to match the existing once on bridge widening projects. On widening project the designer should investigate whether it would be feasible to replace the existing steel bearings with new elastomeric bearings.

The following table, which lists the contract bid item number, bearing description, and unit of measurement, is included for convenience:

Bid Item	Description	Measurement
6040003	Structural Steel (Miscellaneous)	Each

14.7.2 PTFE Sliding Surfaces

Sliding elastomeric bearings accommodate horizontal movements through polytetrafluoroethylene (PTFE) sliding surfaces and rotations through elastomer pads. The thickness of the elastomeric bearing is determined by the rotational and frictional force requirements.

Sliding elastomeric bearings consist of an upper steel bearing plate anchored to the superstructure, a stainless steel undersurface and an elastomeric pad with a teflon coated upper surface. The teflon surface shall be attached to a 3/8-inch minimum thick plate which is vulcanized to the elastomeric pad. Keeper plates may be used for horizontal restraint of the pads. Vertical restraint may be provided by anchor bolts with slotted keeper plates or individual vertical restrainers as appropriate.

Bearing pad dimensions and all details of the anchorage and restraint systems shall be shown in the plans. The required coefficient of friction must also be shown in the plans with the stipulation that the bearing be tested for the required value of the frictional force. This coefficient should be consistent with the values shown in AASHTO LRFD Table 14.7.2.5-1 for a given normal stress. Specifications special provisions are required and should allow for proprietary alternates.

Sliding elastomeric bearings should be considered for applications where regular elastomeric bearing pads would exceed 4 inches in height or where special access details would be required for other proprietary bearings in locations such as at hinges.

The following table, which lists the contract bid item number, bearing description, and unit of measurement, is included for convenience:

Bid Item	Description	Measurement
6015203	Bearings (Sliding Elastomeric)	Each

Neoprene Strips:

Neoprene strips consist of a sliding plate on a continuous neoprene pad conforming to the details shown in Figure 2.

Where appropriate, neoprene strips are the preferred bearing type for post-tensioned box girder bridges. However, neoprene strips are not appropriate for the following applications:

Curved bridges

Bridges with cross slopes greater than 0.02 ft/ft

Bridges skewed greater than 20 degrees

Bridges with spans greater than 125 feet

Bridges where initial shortening due to prestressing is greater than 1 inch

Bridges where the movement including elastic shortening, long term creep, and shrinkage and temperature is greater than 1.5 inches

When neoprene strip bearings are used on wide bearing seats the deflection of the box girder superstructure can chip the corners of the seat. To eliminate this, the corners of the bearing seat should be notched.

No additional bid item number is required for neoprene strips as the cost is included in the bid item for concrete or prestressed member as appropriate.

Figure 2 – Neoprene Strip Details

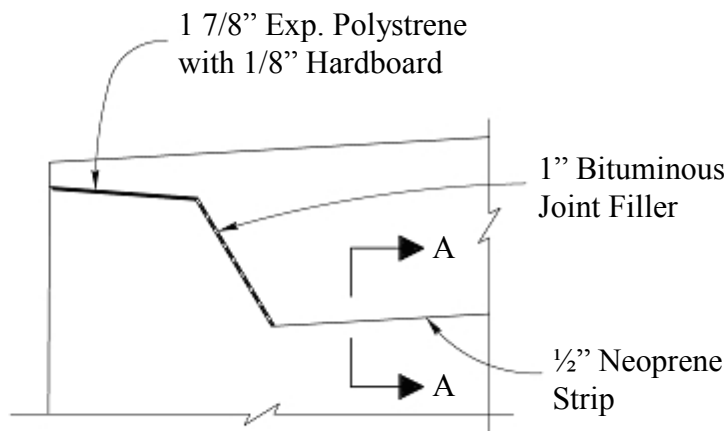

PARTIAL ELEVATION

No Scale

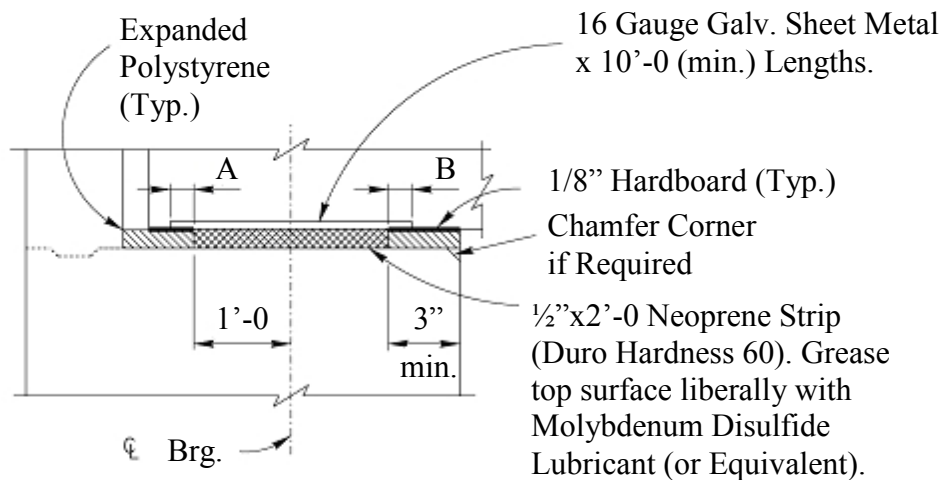

SECTION A-A

No Scale

$A = \text{Calculated Displacement} + 1 \text{ inch (min.)}$

$B = 1.2 * (\text{Bearing Temperature Movement}) + 1/2 \text{ inch (min.)}$

14.7.5 Steel-Reinforced Elastomeric Bearings – Method B

14.7.5.1 General

Steel-reinforced elastomeric bearings may be designed using either of two methods, referred to as Method A and Method B.

Due to their higher load capacity and superior performance, steel reinforced elastomeric bearings constructed using steel laminates should be used in lieu of fiberglass reinforced pads.

Pads shall have a minimum thickness of one inch and be designed in 1/2-inch increments. The use of elastomeric bearing pads should generally be limited to a thickness not greater than 5 inches. If the design pad thickness is 4½ inches or greater, a sliding plate bearing system should be investigated.

Holes will not be allowed in the pads. Tapered pads are not allowed. When the rotation demand exceeds the pad capacity, tapered steel plates shall be used.

The width and length dimensions shall be detailed in increment of one inch. When used with prestressed I-girders, pads shall be sized a minimum width of 2 inches less than the nominal width of the girder base to accommodate the 3/4 inch side chamfer and shall be set back 2 inches from the end of the girder to avoid spalling of concrete from the girder ends.

???Elastomeric bearing pads should not be used at locations where deck joints or bearings limit vertical movements of the superstructure, such as, in older style sliding steel plate joints. Also, these bearings should not be used for bridge widening projects where existing steel bearings are to remain in place.

Elastomeric bearing pads are the preferred bearing type for new steel girders, precast prestressed girders and post-tensioned box girder bridges where neoprene strips are not appropriate.

Elastomeric bearing pads with greased sliding plates used on post-tensioned box girder bridges to limit the required thickness of the pad shall conform to the details shown in Figure 3. For this situation, the pad thickness should be determined based on temperature movements only. The sliding surface will accommodate the initial and long term shortening.

The cost of elastomeric bearing pads or elastomeric bearing pads with greased sliding plates is included in the bid item of the superstructure elements. As such these bearings are not bid as a separate item.

The following data shall be shown on the plans:

Length, width and thickness of pad

Design Method (A or B)

Design Load

Low Temperature Zone (A, B or C)

Elastomer Grade (0 or 2)

Shear Modulus

Durometer Hardness

The following note shall be added to the plans:

Elastomeric bearing pads shall be steel laminated neoprene pads.

The number and type of laminates shall not be detailed on the plans but are covered in the ADOT Standard Specifications for Road and Bridge Construction.

Normally, Design Method A shall be used. However, for bridges with large reaction forces, Design Method B may be used provided more rigorous testing will be performed.

14.7.5.2 Material Properties

Only the following three combinations of shear modulus and durometer hardness should be specified:

Shear Modulus (psi)	Durometer Hardness
110	50
130	55
160	60

The following should be used as a guide for determining low temperature zones and elastomer grade:

Elevation (ft)	Zone	Elastomer Grade
Below 3000	A	0
3000 - 6000	B	2
Above 6000	C	2*

* To specify an Elastomer Grade 2 for application above an elevation of 6000 feet the design engineer should incorporate the special provisions described in AASHTO LRFD Article 14.7.5.2. This will eliminate the need for the stringent testing requirements of the higher elastomer grades that may result in construction delays.

Figure 3 – Elastomeric Bearing Pads with Greased Sliding Plates

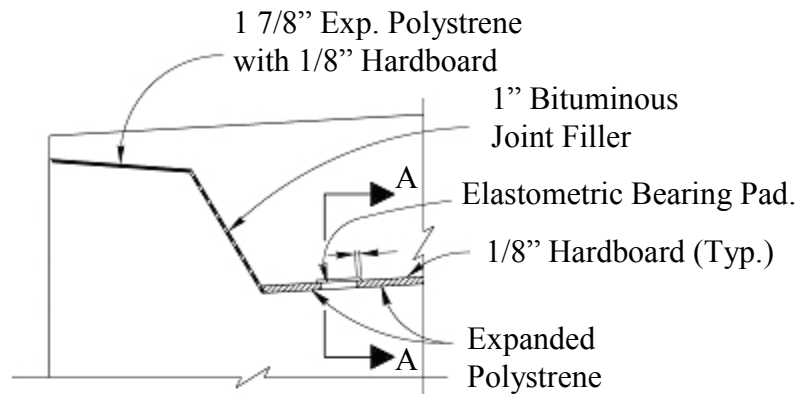

PARTIAL ELEVATION

No Scale

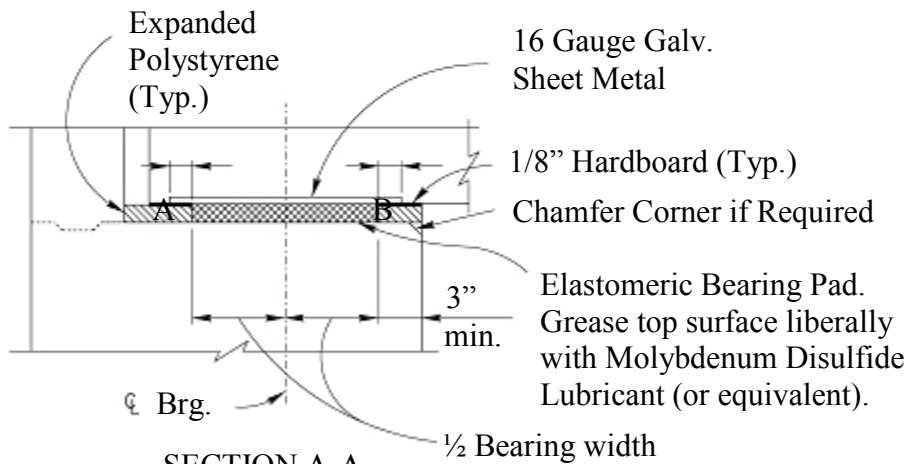

SECTION A-A

No Scale

$$A = \text{Calculated Displacement} + 1 \text{ inch (min.)}$$

$$B = 1.2 * (\text{Bearing Temperature Movement}) + \frac{1}{2} \text{ inch (min.)}$$

14.7.6 Elastomeric Pads and Steel-Reinforced Elastomeric Bearings - Method A

Normally, Design Method A shall be used. However, for bridges with large reaction forces, Design Method B may be used provided more rigorous testing will be performed.

14.7.6.3 Design Requirements

14.7.6.3.5 Rotation

The current AASHTO LRFD Design Specifications equation for stress due to rotation for steel reinforced elastomeric bearings is very restrictive and difficult to satisfy. In lieu of this, the AASHTO rotation criteria prior to 1997 should be used. The equation from the AASHTO Standard Specifications, fifteenth edition, is as follows:

$$\Theta_s < 2\delta_c/L$$

Where:

δ_c is the compressive deflection of the pad as based on the durometer hardness and the appropriate stress strain curve.

High-Load Multi-Rotational Bearings:

High-load multi-rotational fixed bearings consist of a rotational element of the Spherical-type, Pot-type, or Disc-type. High-load multi-rotational expansion bearings consist of a rotational element of the Spherical-type Pot-type, or Disc-type, sliding surfaces to accommodate translation and guide bars to limit movement in specified directions when required. These bearing types can be found in AASHTO LRFD Specifications, Articles 14.7.3, 14.7.4, and 14.7.8 respectively.

Spherical bearings consist of a rotational element comprised of a spherical bottom convex plate and mating spherical top concave plate. Pot bearings consist of a rotational element comprised of an elastomeric disc totally confined within a steel cylinder. Disc bearings consist of rotational element comprised of a polyether urethane disc confined by upper and lower steel bearing plates and restricted from horizontal movement by limiting rings and a shear restriction mechanism.

Knowledge and performance of this bearing type is constantly being upgraded. As such, when its usage is required, the design engineer shall research the current AASHTO LRFD Specifications, the most up-to-date bearing research and ADOT design requirements to develop the most current state-of-the-art Special Provisions. The design and manufacture of multi-rotational bearings relies heavily on the principles of engineering mechanics and extensive practical experience in bearing design and manufacture. Therefore, in special cases where structural requirements fall outside normal limits, a bearing manufacturer should be consulted. Design engineers are responsible for determining the applicability of the AASHTO LRFD Specifications and advances in bearing technology to the above criteria on their specific project. Close coordination with ADOT Bridge Group shall be maintained. These high performance bearings shall be included in contract bid document and measured as each.

The following table, which lists the contract bid item number, bearing description, and unit of measurement, is included for convenience:

Bid Item	Description	Measurement
6015200	High-Load Multi-Rotational Bearings	Each

14.7.9 Guides and Restraints

14.7.9.1 General

Guides and restraining devices are used to contain movements in a specified direction. Restraining devices shall be designed to resist the imposed loads including seismic loads as specified in AASHTO LRFD Article 3.4.

Restraining devices could include concrete shear keys or end blocks, horizontal or vertical cable restrainers or mechanical restraining devices which could be an integral part of a bearing or a separate system. Restraining devices, containing vertical displacements at expansion ends, shall be designed to allow for inspection and future replacement of bearings.

Allowable restraining devices include, but are not limited to the followings:

- Vertical fixed restrainers,
- Vertical expansion restrainers,
- External shear keys,
- Internal shear keys, and
- Keyed hinges.

Vertical Fixed Restrainers:

Vertical fixed restrainers consist of cable and appropriate hardware as shown in Figure 5. These restrainers are designed to allow rotation but no translation in either horizontal or vertical directions. Vertical fixed restrainers should be designed for a minimum vertical uplift force of 10% of the dead load reaction. Each cable may be assumed to have an allowable working load of 21 kips. Fixed restrainers are typically orientated with cables placed along the centerline of bearing as shown in Figure 4.

Figure 4 – Orientation Plan – Fixed Restrainer

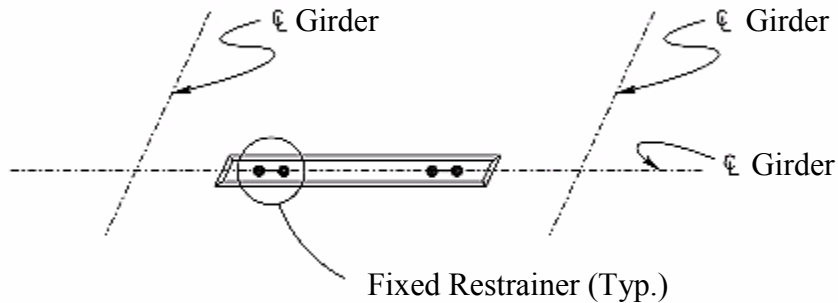

Refer to Figure 5 for the fixed restrainer detail. This vertical fixed restrainer detail can be found in the Bridge Cell Library under the cell name VR2 (Fix Restr. Det).

Figure 5 – Fixed Restrainer Detail

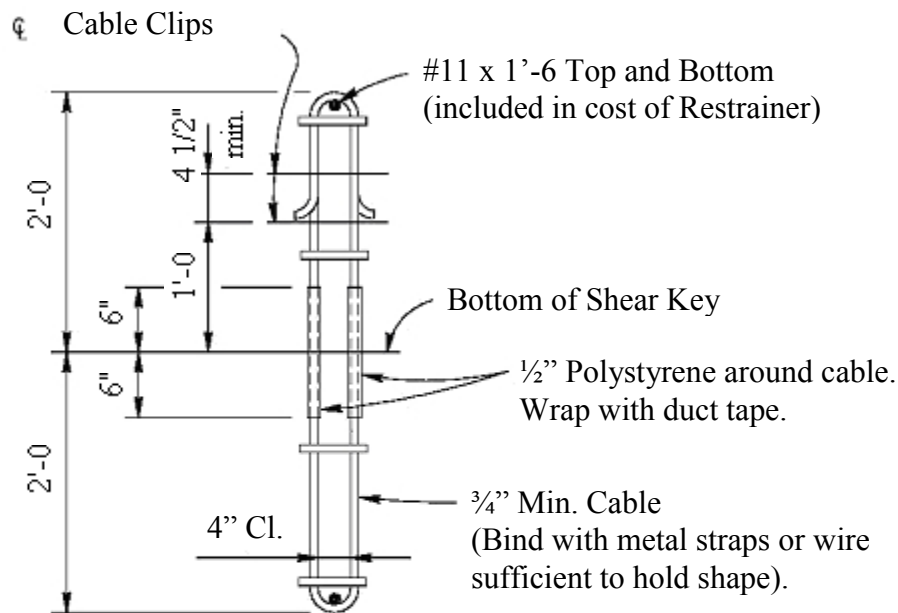

NOTES:

Restrainer Cables shall be 3/4" preformed 6 x 19 galvanized with the minimum breaking strength of 42 Kips. One sample of cable 3 feet in length shall be furnished to the Engineer for testing.

The following table, which lists the contract bid item number, restrainer description, and unit of measurement, is included for convenience:

Bid Item	Description	Measurement
6015101	Restrainers, Vertical Earthquake (Fixed)	Each

Vertical Expansion Restrainers:

Vertical expansion restrainers consist of cable and appropriate hardware as shown in Figure 6. These restrainers are designed to allow rotation and longitudinal translation. These restrainers do not prohibit transverse movement. Shear keys are required to arrest transverse movement. Some limited vertical displacement is allowed to permit replacement of bearings if required. These devices are designed for a maximum movement of 4 inches. Vertical expansion restrainers should be designed for a minimum vertical uplift force of 10% of the dead load support reaction. Each cable may be assumed to have an allowable working load of 21 kips.

Refer to Figure 6 for expansion restrainer detail. This vertical expansion restrainer detail can be found in the Bridge Cell Library under the cell name VR1 (Exp Restr. Det).

The following table, which lists the contract bid item number, restrainer description, and unit of measurement, is included for convenience:

Bid Item	Description	Measurement
6015102	Restrainers, Vertical Earthquake (Expansion)	Each

Figure 6 – Expansion Restrainer Detail

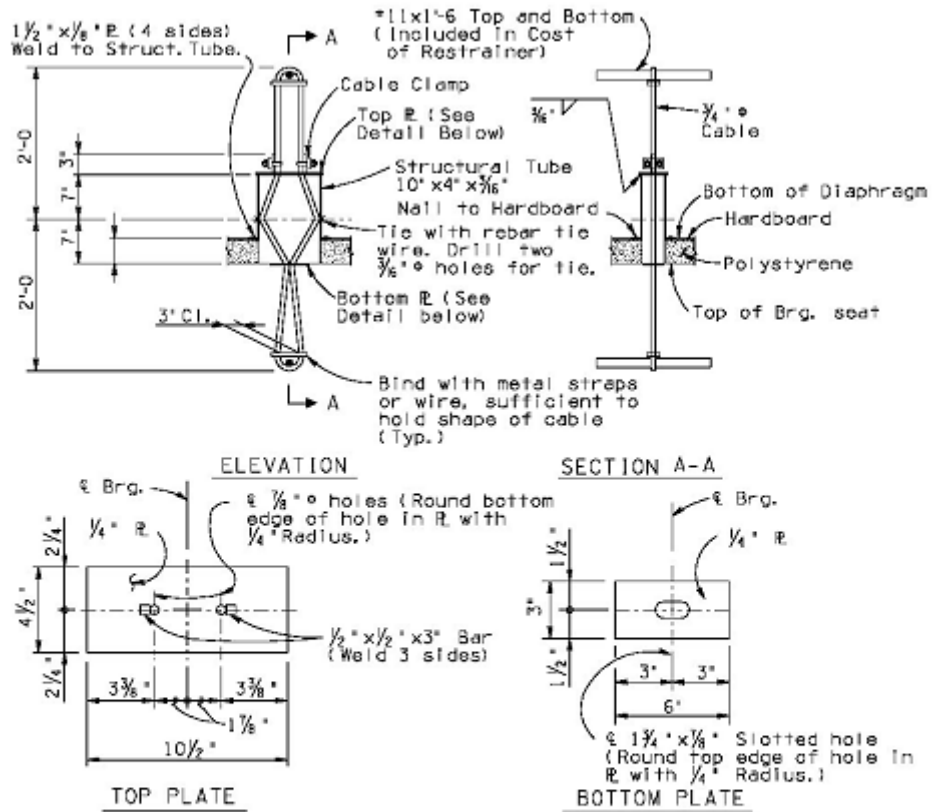

NOTES:

Seal all openings in structural tube to prohibit concrete intrusion.

Restrainer Cables shall be 3/8" preformed 6x19 galvanized with the minimum breaking strength of 42 kips. One sample of cable 3 feet in length shall be furnished to the Engineer for testing.

Expansion restrainers are placed along the center of bearing with the long side of the cable box placed parallel to the girders see Figure 7.

Figure 7 – Orientation Plan - Expansion Restrainer

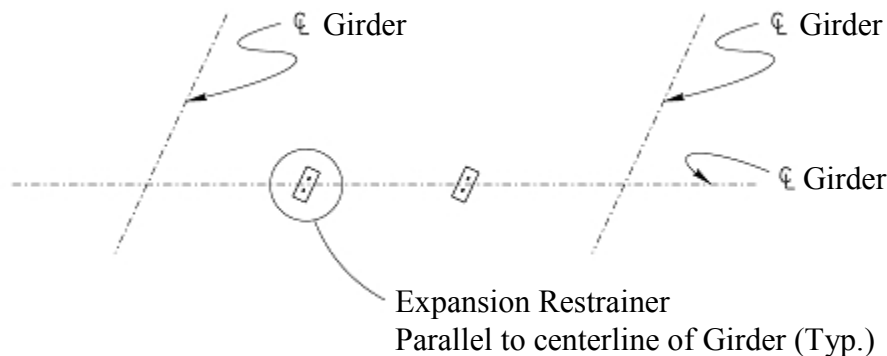

External Shear Keys:

External shear keys are reinforced concrete blocks designed to limit transverse displacement while allowing longitudinal and rotational movements. External shear keys are preferred to internal shear keys because of ease of construction. Also, external shear keys are more accessible for inspection and maintenance.

Internal Shear Keys:

Internal shear keys are reinforced concrete blocks designed to limit transverse displacement while allowing longitudinal and rotational movements.

Keyed Hinges:

A keyed hinge is a restraining device, which limits displacements in both horizontal directions while allowing rotation. Vertical fixed restrainers should be considered as reinforcing steel for shear friction design on the concrete shear key with an allowable working load of 21 kips per cable.

Restrainer Applications:

For a typical expansion seat abutment where restraining devices are required, the restraining devices will consist of vertical expansion restrainers and external shear keys.

For a typical pinned seat abutment for a post-tensioned box girder bridge, restraining devices will consist of vertical fixed restrainers and external shear keys. For a typical pinned seat abutment for a prestressed girder bridge, restraining devices will consist of vertical fixed restrainers and external or internal shear keys.

For a typical expansion pier, restraining devices will consist of vertical expansion restrainers and internal shear keys.

For a typical pinned pier, restraining devices will consist of vertical fixed restrainers and internal shear keys or a keyed hinge.