

Note to Designer: The information presented in this Standard Detail has been prepared in accordance with recognized engineering principles and is for general use. It should not be used for specific application without competent professional examination and verification of its suitability and applicability by a licensed professional engineer. Contents within the inner border line shall not be altered.

NO.	DATE	DESCRIPTION OF REVISIONS
1	8-99	Original Issue
2	9-99	Bid Item No. Note
3	3-09	General Update, Revised width of parapet and sidewalk.
4		

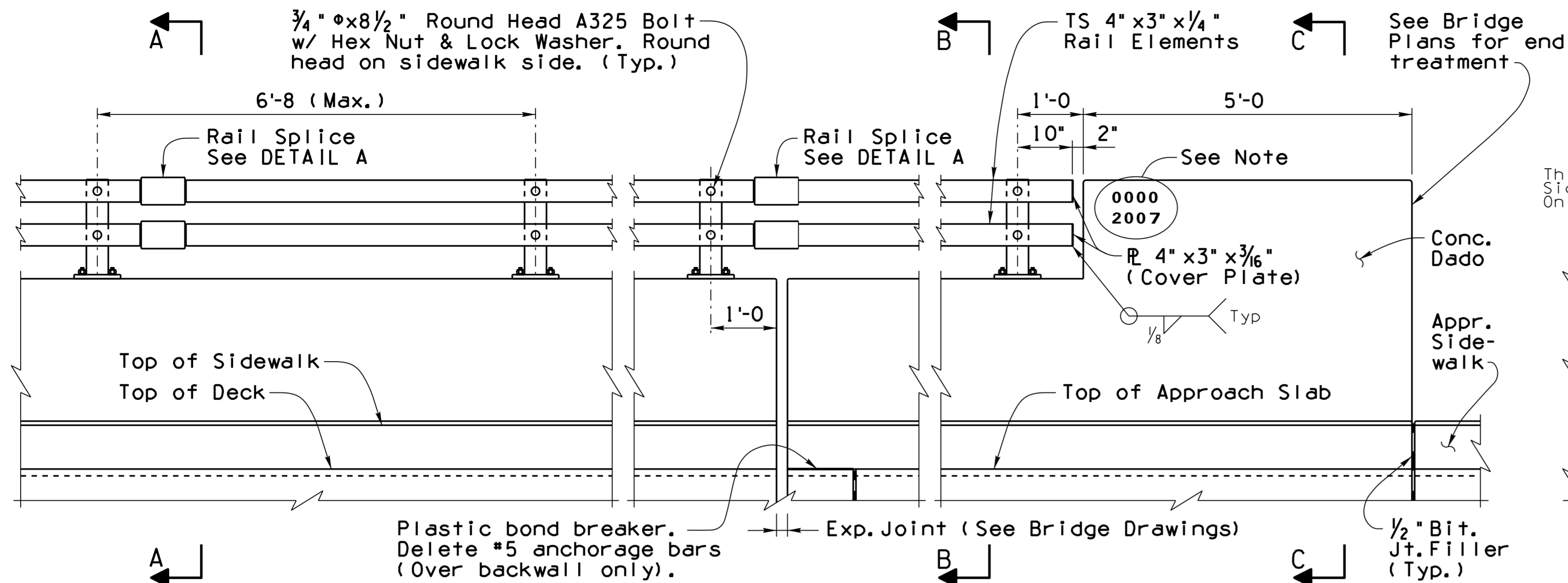

TYPICAL PANEL ELEVATION

ELEVATION AT EXP. JT.

ELEVATION AT END POST

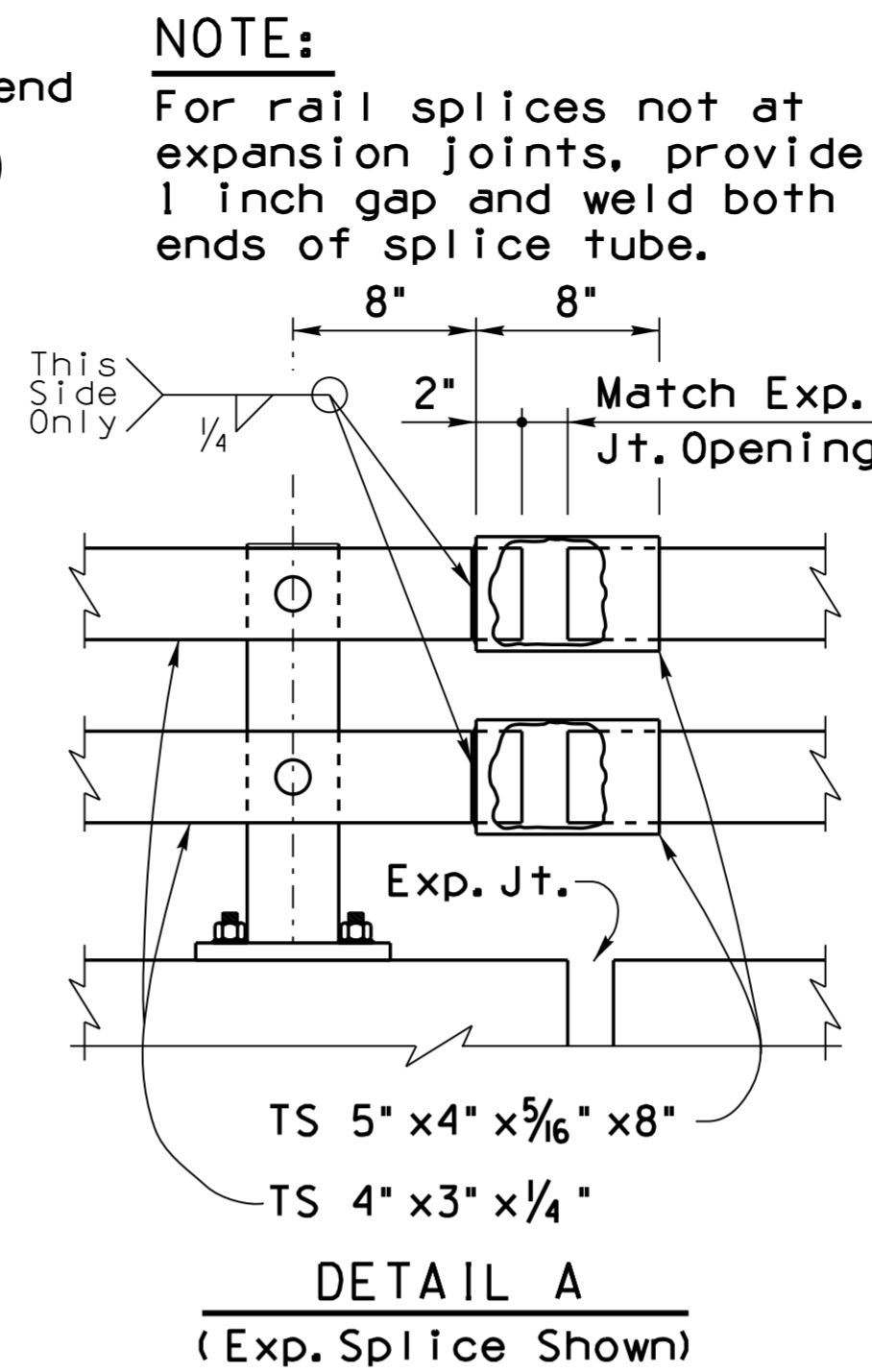

GENERAL NOTES:

Construction Specification - Arizona Department of Transportation Standard Specifications for Road and Bridge Construction, latest Edition.
 Design Specifications - AASHTO LRFD Bridge Design Specifications, 4th Edition 2007.

This barrier is structurally evaluated as meeting the requirements of NCHRP Report 350 Test Level 4.

All Concrete shall be Class "S" (f'c = 4000 psi).

Reinforcing steel shall conform to ASTM Specification A615. All reinforcing shall be furnished as Grade 60. All reinforcing shall be epoxy coated at locations above EL.4000 ft.

All bends and hooks shall meet the requirements of AASHTO LRFD Article 5.10. All bend dimensions for reinforcing steel shall be out-to-out of bars. All placement dimensions for reinforcing steel shall be to center of bars unless noted otherwise.

All reinforcing steel shall have $\frac{1}{2}$ inch clear cover unless noted otherwise.

Structural tubing (TS) shall be ASTM A500 Grade B. All other structural steel shall conform to ASTM A36 unless noted otherwise.

All welding shall conform to the requirements of the American Welding Society, ANSI/AASHTO/AWS D1.5 Bridge Welding Code, latest Edition.

Concrete parapets on continuous superstructures shall have $\frac{1}{2}$ " bituminous joint filler in open joints over piers. See bridge drawings for details.

Imbed $\frac{1}{2}$ ". Bridge Number and Year Built, using $1\frac{1}{2}$ " w x 2" h number impressions in concrete, located as shown at the approach end of the outside lane.

Labor and materials for railing, parapet, dado, anchorage bars, sidewalk and PEDESTRIAN FENCE (SD 1.05) are included in the pay item (Item No. 601132).

Dimensions shall not be scaled from drawings.

Item No. 601132 COMBINATION PEDESTRIAN-TRAFFIC BRIDGE RAILING
 Measure: Linear Foot

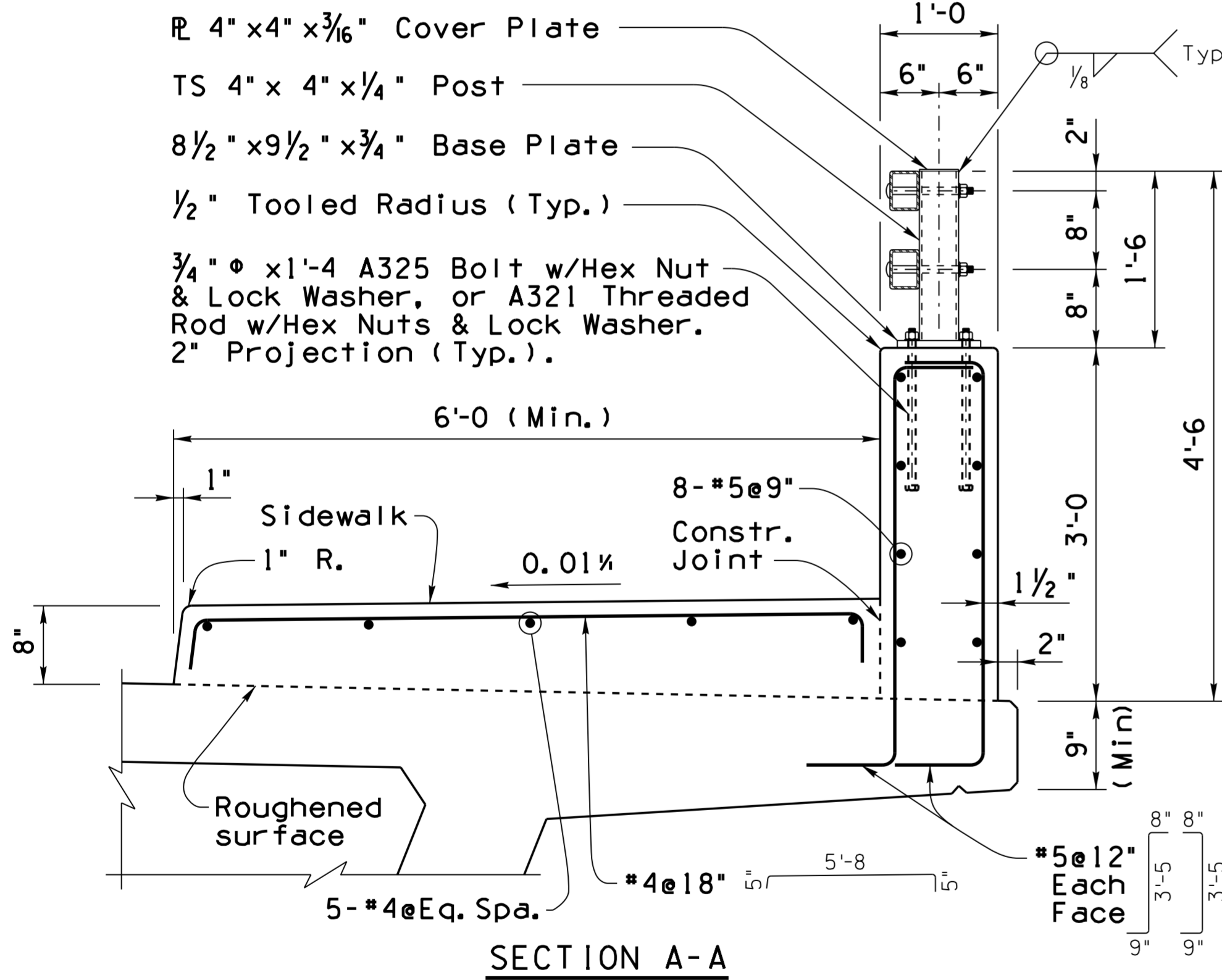

SECTION A-A

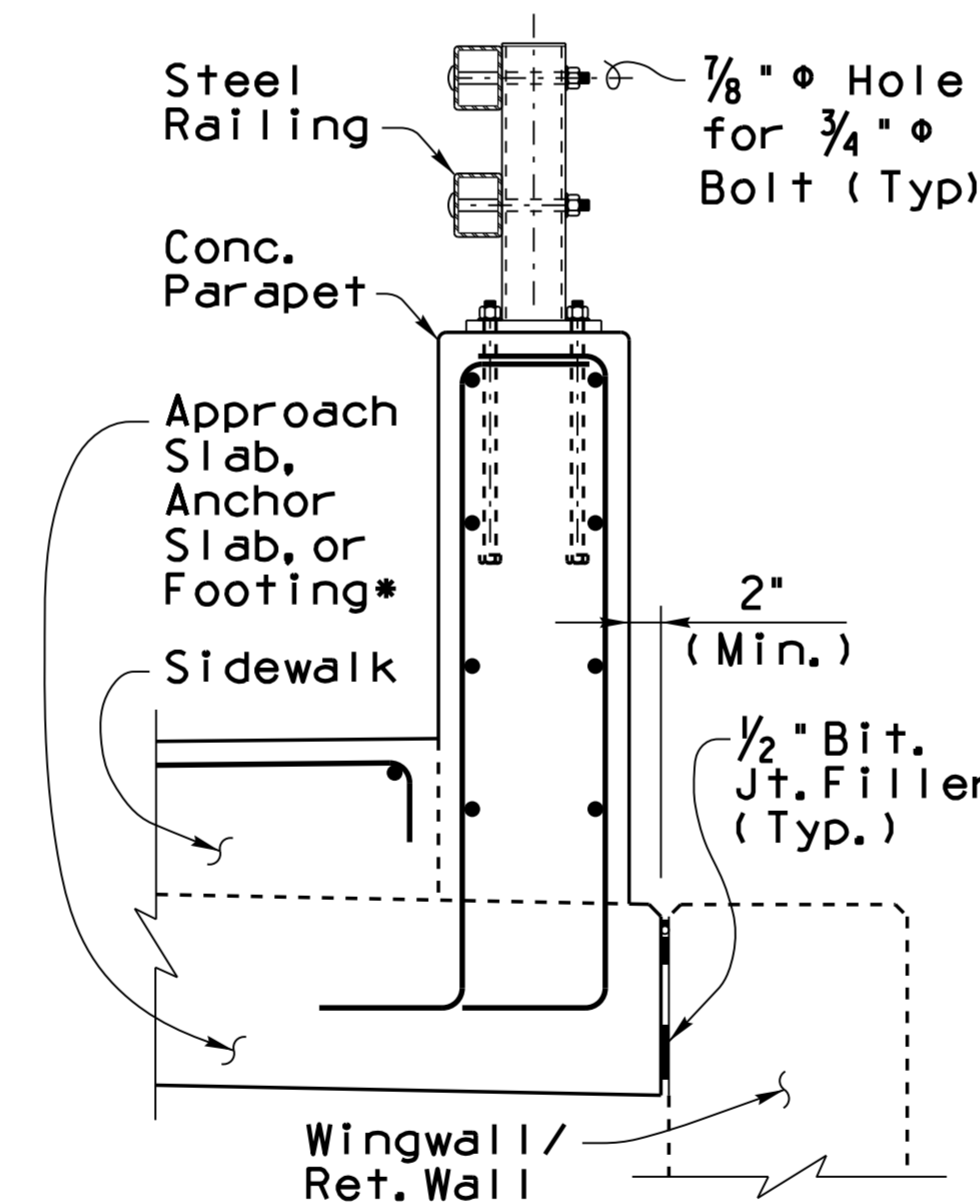

SECTION B-B

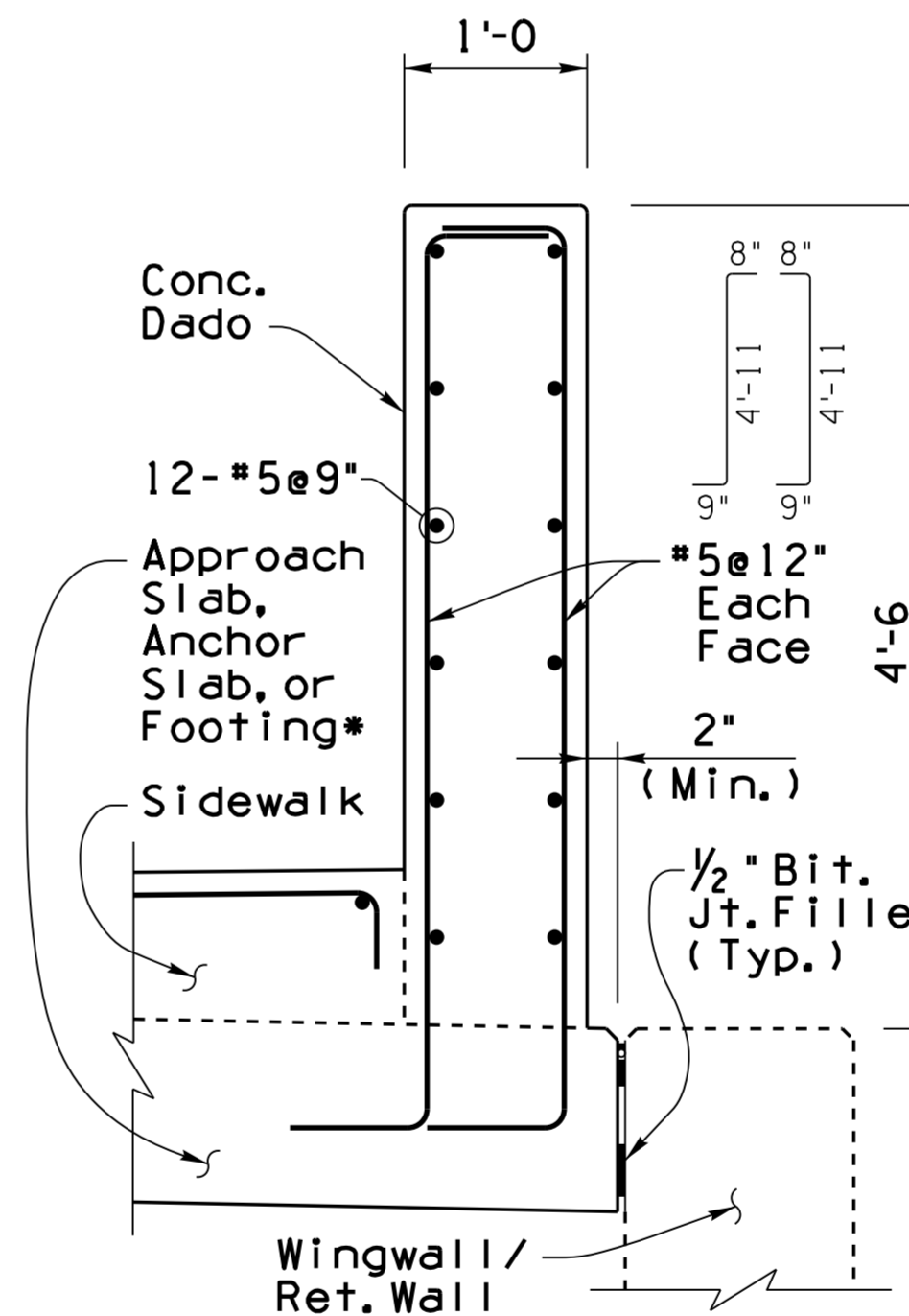

SECTION C-C

* See SD 1.01 for footing details.

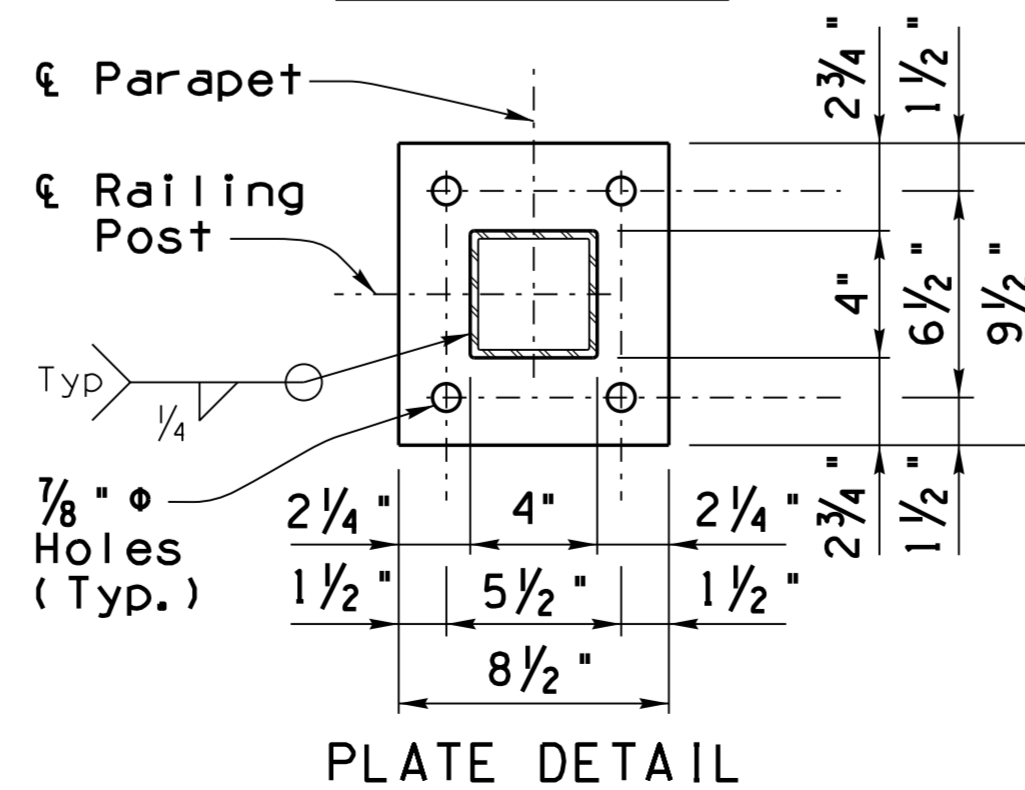

RAILING NOTES:

See Bridge Plans for rail layout, elevation, joint locations and rail end treatments.
 All exposed steel edges shall be ground smooth. All structural steel rail assembly components shall be galvanized after fabrication in accordance with ASTM A123. All galvanizing that has been damaged in handling, transportation or welding shall be repaired by the application of a paste compound of an approved zinc powder and flux.
 All post bolt heads shall be on sidewalk side. All bolts, nuts and washers shall be galvanized in accordance with the requirements of ASTM A153.
 For fence attachment details, see Structure Detail SD 1.05. (Lower rail tube is not required with fence.)

DESIGN APPROVED <i>Shafiq U. Hasan</i>		ARIZONA DEPARTMENT OF TRANSPORTATION INFRASTRUCTURE DELIVERY AND OPERATIONS DIVISION BRIDGE GROUP STRUCTURE DETAIL	
APPROVED FOR DISTRIBUTION <i>Teon A. Nehme</i>		COMBINATION PEDESTRIAN-TRAFFIC BRIDGE RAILING	
ROUTE	PROJECT NO.	FA NO.	DRAWING NO. SD 1.04
LOCATION			SHEET NO. OF