

Note to Designer:
 The information presented in this Standard Detail has been prepared in accordance with recognized engineering principles and is for general use. It should not be used for specific application without competent professional examination and verification of its suitability and applicability by a licensed professional engineer. Contents within the inner border line shall not be altered.

NO.	DESCRIPTION OF REVISIONS	MADE BY	DATE
1	Original Issue	6/11/07	8-99
5	General Update, This Block	6/11/07	11-07
6	General Update, This Block	6/11/07	3-09
7			

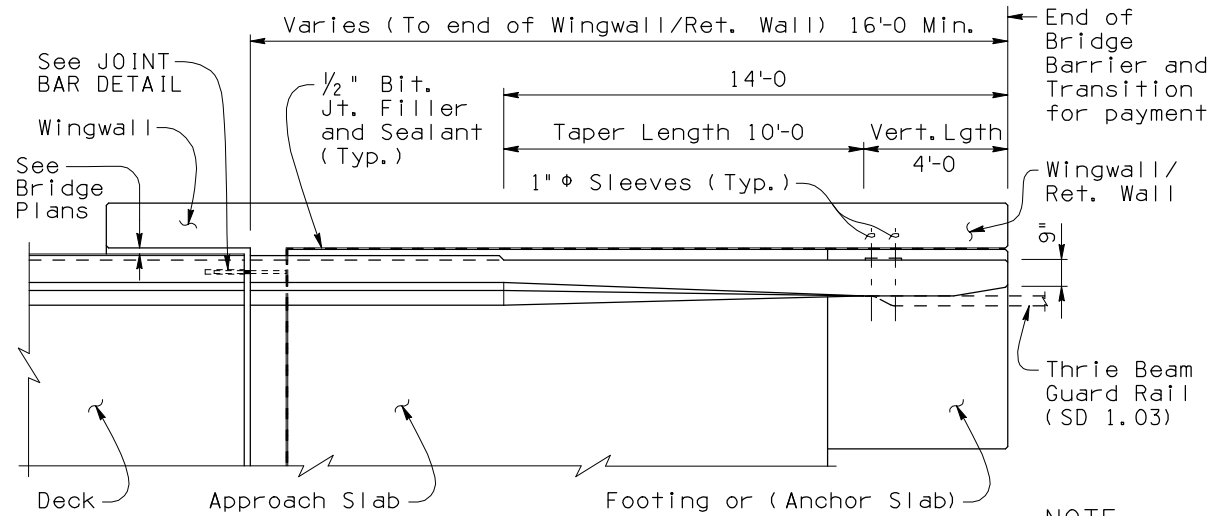

PLAN

NOTE:
 The 32 inch barrier height is measured from the top of the (future) wearing surface (2 inch allowance).

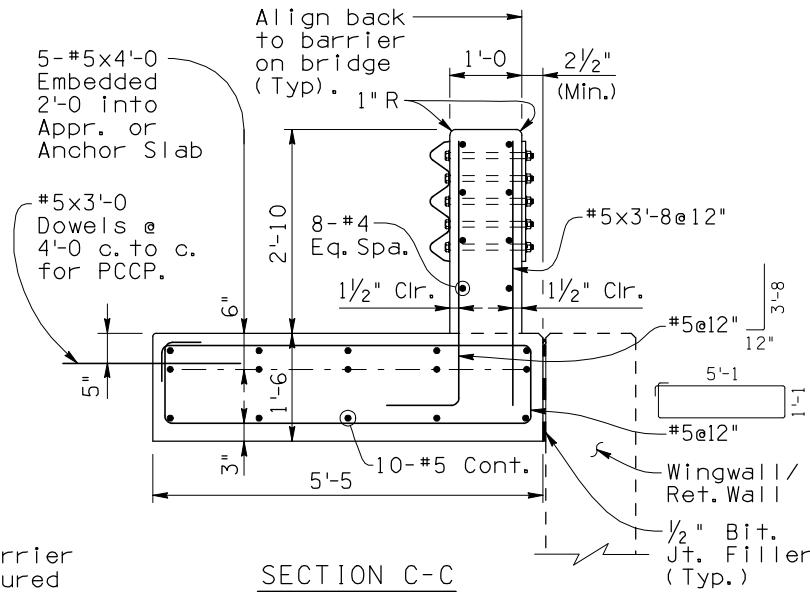

SECTION C-C

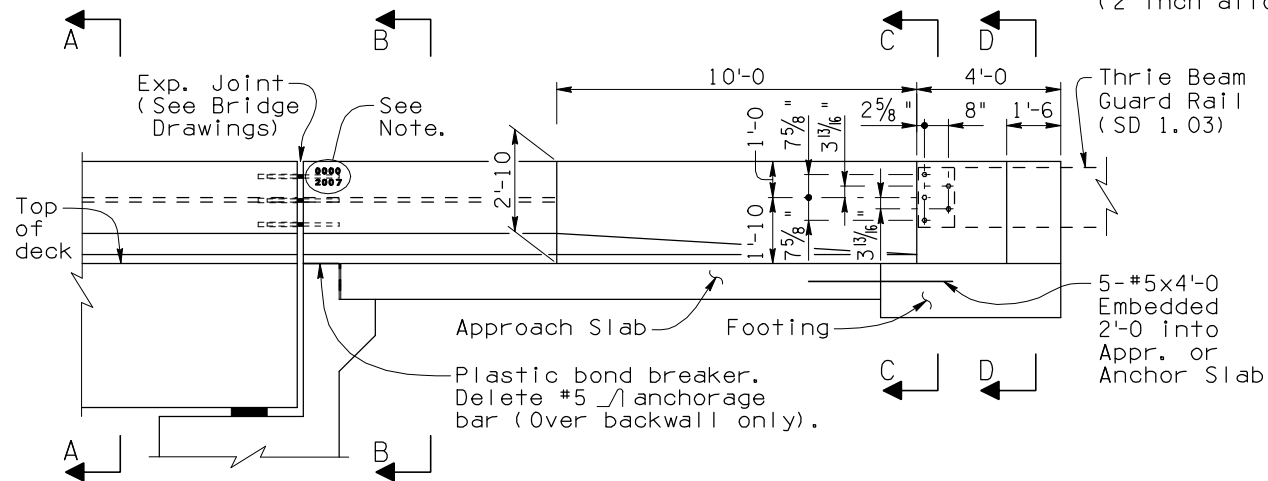

ELEVATION

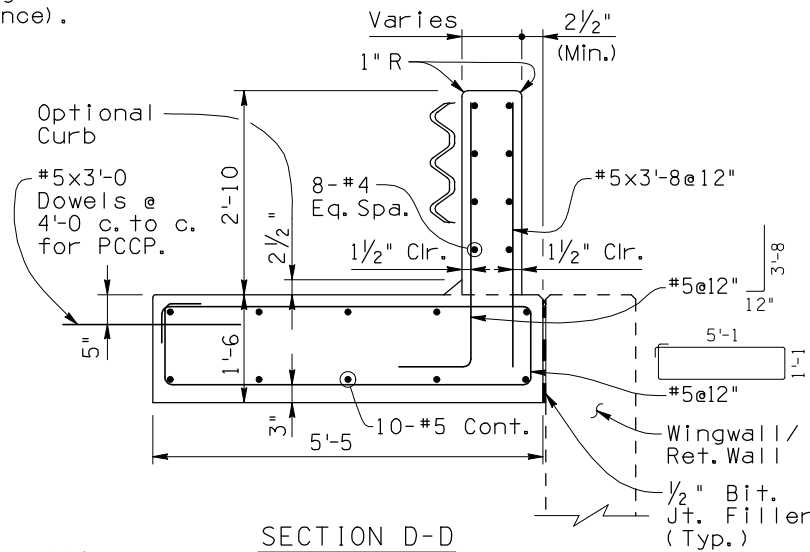

SECTION D-D

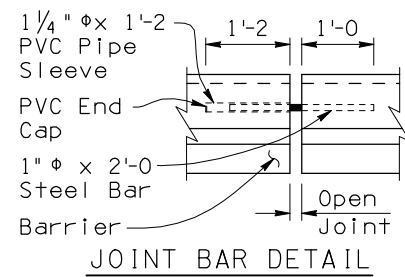

JOINT BAR DETAIL

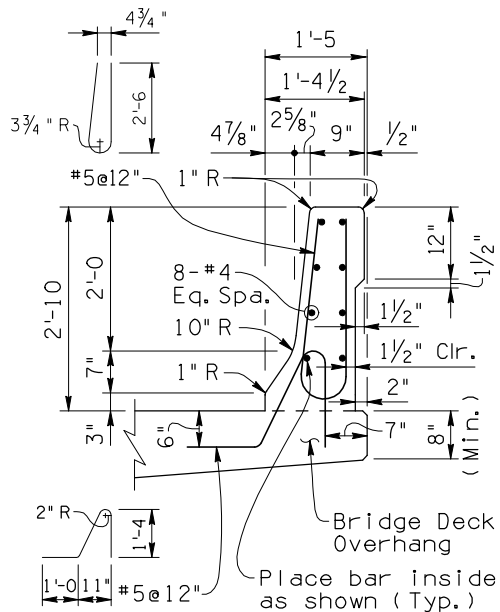

SECTION A-A

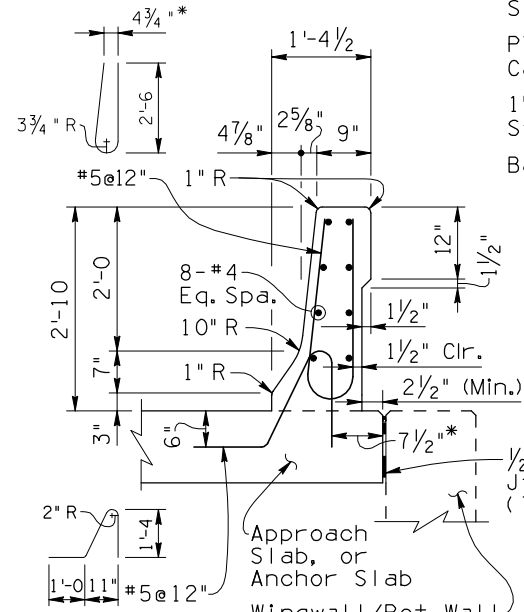

SECTION B-B

*Varies at taper length

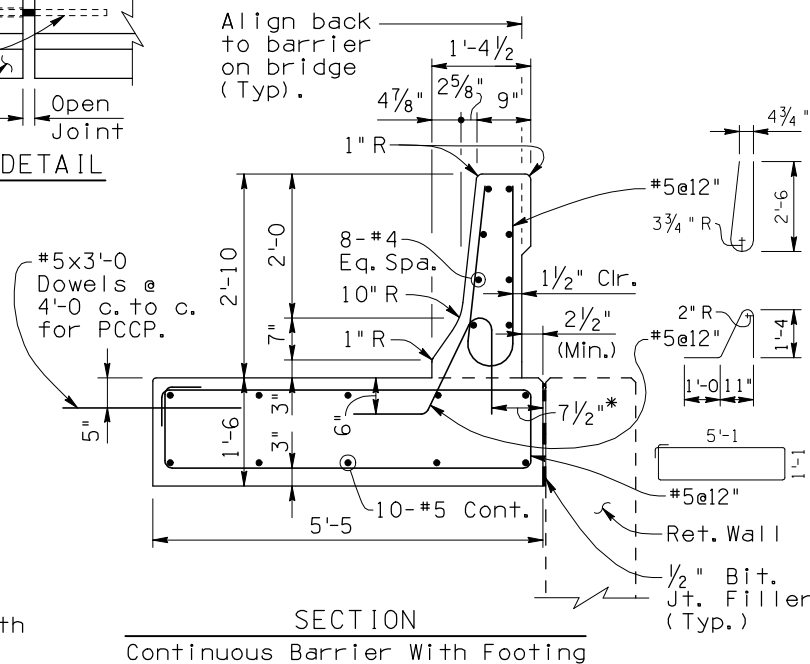

SECTION

Continuous Barrier With Footing

GENERAL NOTES:

Construction Specification - Arizona Department of Transportation Standard Specifications for Road and Bridge Construction, latest Edition.

Design Specifications - AASHTO LRFD Bridge Design Specifications, 4th Edition 2007.

This barrier has been successfully crash tested and is structurally evaluated as meeting the requirements of NCHRP Report 350 Test Level 4.

All Concrete shall be Class "S" (f'c = 4000 psi).

Reinforcing steel shall conform to ASTM Specification A615. All reinforcing shall be furnished as Grade 60. All reinforcing shall be epoxy coated at locations above EL.4000 ft.

All bends and hooks shall meet the requirements of AASHTO LRFD Article 5.10. All bend dimensions for reinforcing steel shall be out-to-out of bars. All placement dimensions for reinforcing steel shall be to center of bars unless noted otherwise.

All reinforcing steel shall have 2 inch clear cover unless noted otherwise.

Concrete barriers on continuous superstructures shall have 1/2 inch bituminous joint filler in open joints over piers. See bridge drawings for details.

Imbed 1/2 inch, Bridge Number and Year Built, using 1 1/2 inch x 2 inch number impressions in concrete, located as shown at the approach end of the outside lane.

Anchorage bars are included in the pay item for barrier (Item No. 6011130).

Omit bridge barrier transition when concrete barrier is continuous beyond bridge.

Dimensions shall not be scaled from drawings.

Item No. 6011130 F-SHAPE BRIDGE CONCRETE BARRIER AND TRANSITION (32")
 Measure: Linear Foot

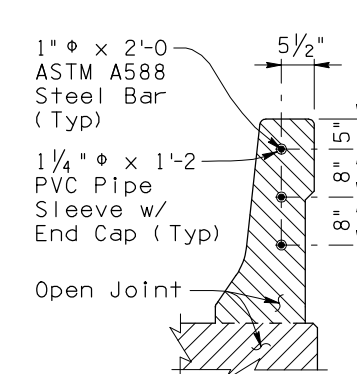

OPEN JOINT DETAIL
 At Expansion Joints

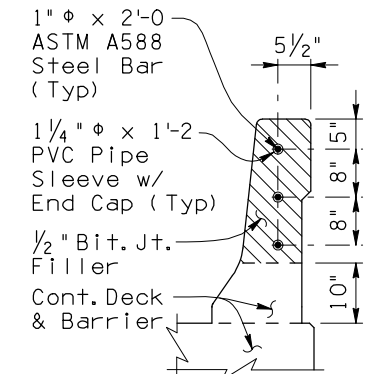

OPEN JOINT DETAIL
 Over Continuous Piers

DESIGN APPROVED <i>Shafiq U. Hasan</i>		ARIZONA DEPARTMENT OF TRANSPORTATION INTERMODAL TRANSPORTATION DIVISION BRIDGE GROUP STRUCTURE DETAIL	
APPROVED FOR DISTRIBUTION <i>Tean A. Nehme</i>		F-SHAPE BRIDGE CONCRETE BARRIER AND TRANSITION (32") NOMINAL	
ROUTE	PROJECT NO.	FA NO.	DRAWING NO. SD 1.01
LOCATION			SHEET NO. OF