

NO	DESCRIPTION OF REVISIONS	MADE BY	DATE
1	REISSUED STANDARD AS SHEET 6 OF 7	RLF	9/04
2	ADDED GENERAL NOTE 4	RLF	7/05
3	REVISED NOTE	RLF	7/05
4	DELETED GENERAL NOTE 4	RLF	5/07

GENERAL NOTES

- For median widths 5'-5" and less, the Detectable Warning Strip shall be continuous from back-of-curb to back-of-curb. The Detectable Warning Strip shall not extend beyond the back of curb. Modular units such as bricks or tiles shall be used to construct the Detectable Warning Strip. Partial domes at the edge of the Strip shall be ground flush with the brick or tile surface.
 - Use Type A1 curb if median is to be landscaped.
 - Single curb shown; see plans for Curb & Gutter application.
- (2) ■ Pedestrian Push Button Pole When Shown on Plans. See Traffic Signal Plans for Additional Information
 (4) ● 10" Maximum to Face of Pedestrian Push Button

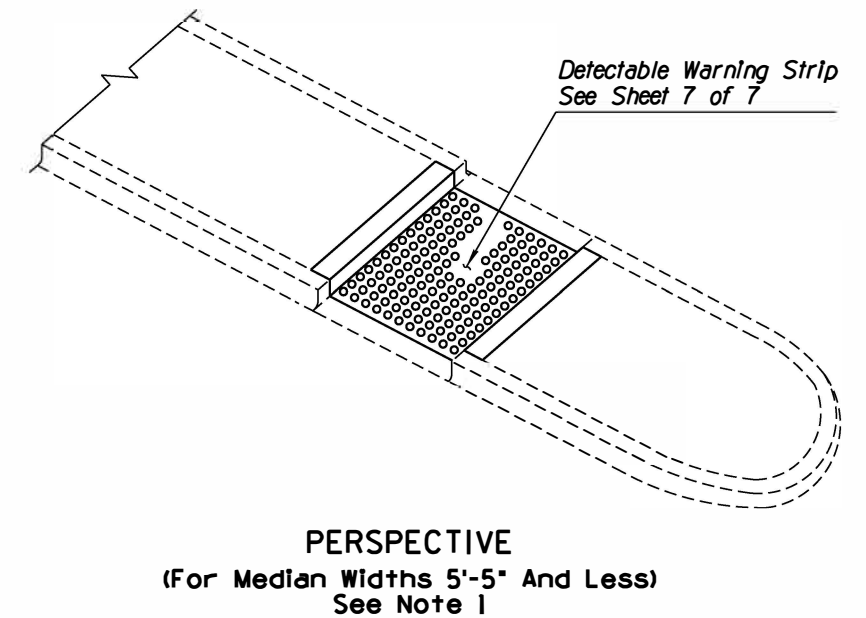
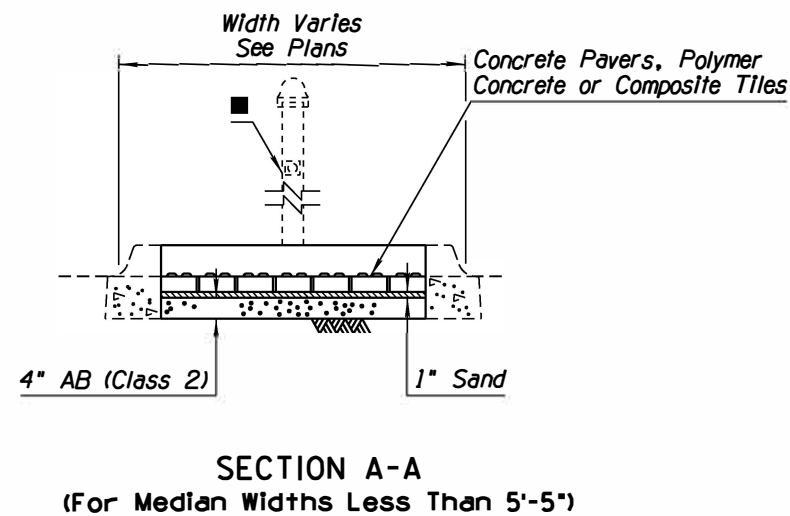
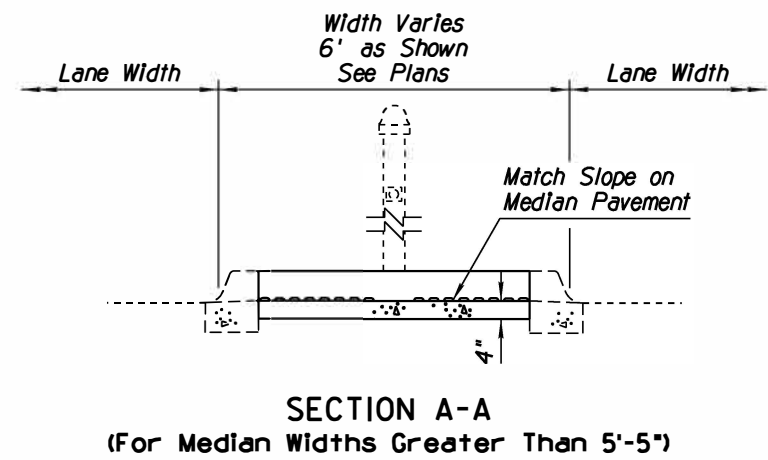
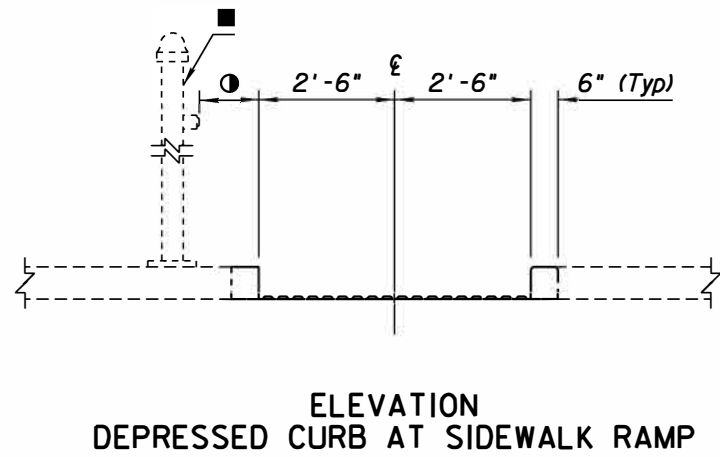
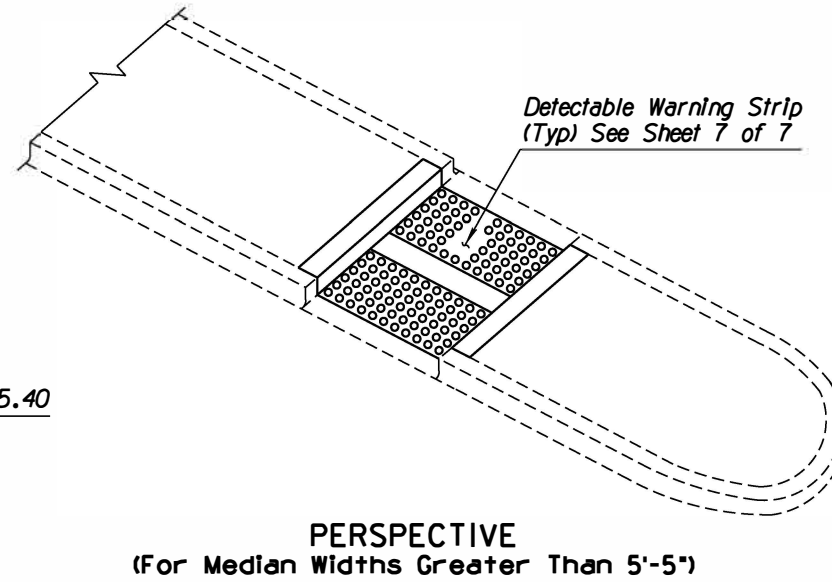
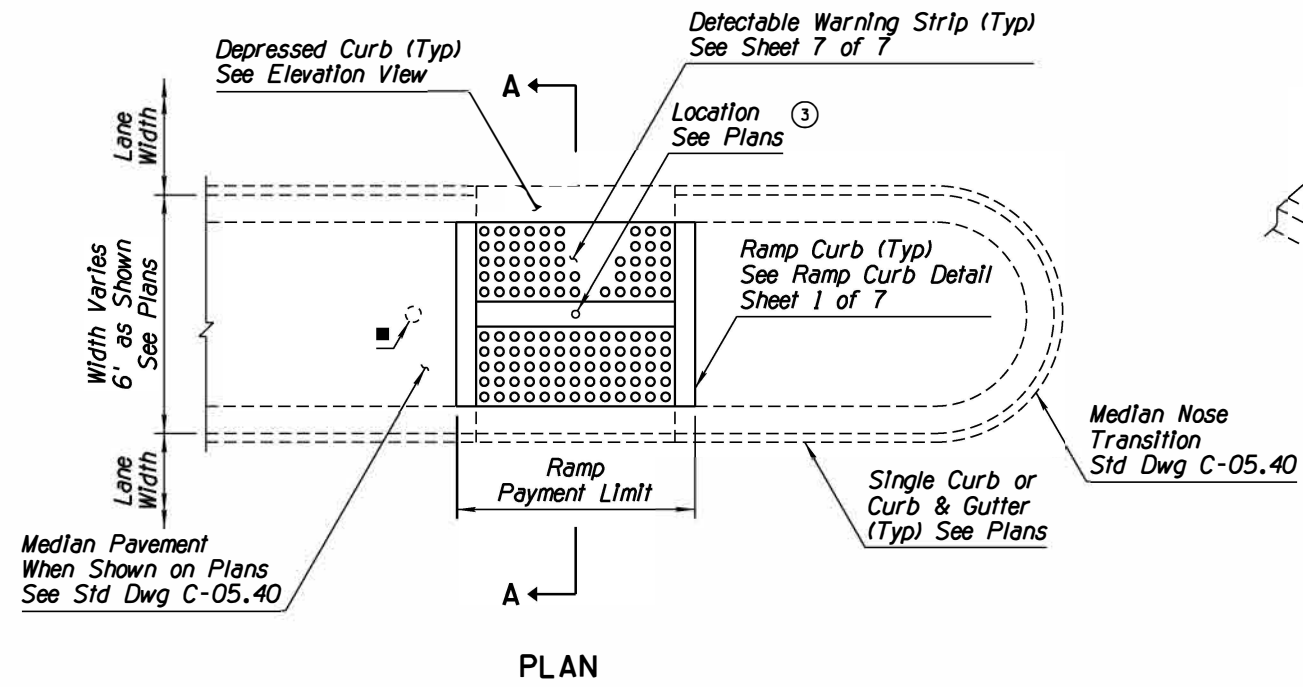

SIDEWALK RAMP AT MEDIAN ISLAND CROSSING

APPROVED FOR DESIGN	STATE OF ARIZONA DEPARTMENT OF TRANSPORTATION ROADWAY STANDARD DRAWINGS	REV. 5/12
APPROVED FOR DISTRIBUTION	SIDEWALK RAMP TYPE F	DRAWING NO. C-05.30 Sheet 6 of 7