

Note to Designer: The information presented in this Standard Drawing has been prepared in accordance with recognized engineering principles and is for general use. It should not be used for specific application without competent professional examination and verification of its suitability and applicability by a licensed professional engineer. Comments within the inner border line shall not be altered.

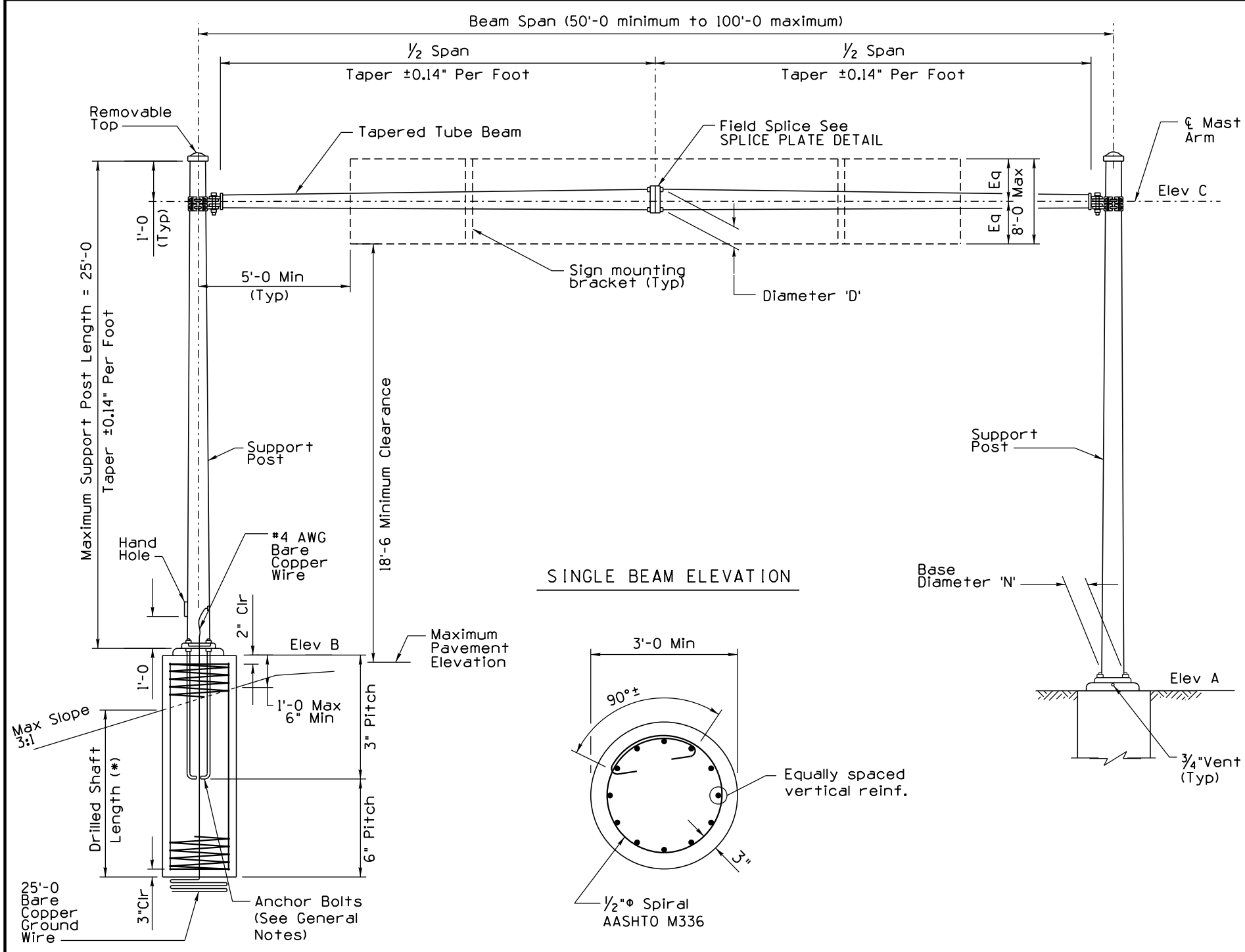

SINGLE BEAM ELEVATION

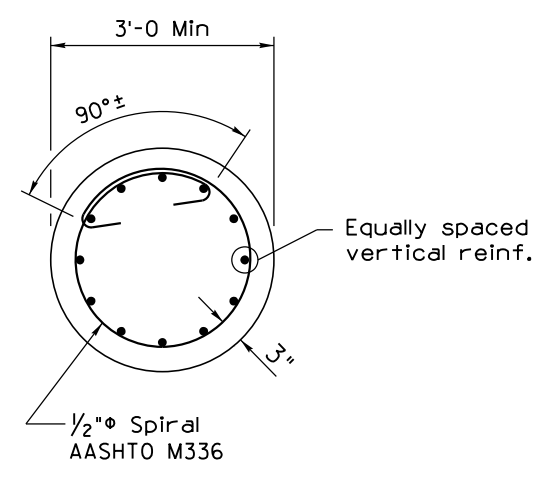

(*) DRILLED SHAFT NOTES:

Drilled shaft foundation design shall be based on uniform soil conditions with the following soil parameters: Unit Weight = 120 pcf
 $k = 70$ pci
 Angle of internal friction = 33°
 Depth or design should be revised by the Engineer for weaker soils or rock embedment.

WELDING NOTES:

Welding of structural tubing shall conform to the requirements of the American Welding Society, Structural Welding Code, D1.1, latest Edition.
 All welding shall be continuous unless noted otherwise. All butt welds shall be full penetration using prequalified welding procedures and shall be tested by ultrasonic testing. All butt welds shall be ground flush, full width.
 Grinding striations shall be parallel to the length of member.
 The tube to base plate weld shall be tested by ultrasonic testing. Any detected shallow toe cracks shall be repaired in the shop.

Structure	
Span A	Item No.
50'-0 to 70'-0	6060057
70'-1 to 85'-0	6060058
85'-1 to 100'-0	6060059

GENERAL NOTES:

All materials and construction shall conform to the requirements of the Arizona Department of Transportation Standard Specifications for Road and Bridge Construction.
 Design Specifications - AASHTO Standard Specification for Structural Supports for Highway Signs, Luminaires, and Traffic Signals, 6th Edition (2013) with 2015 Interim Revisions
 All concrete shall be Class "S".
 Reinforcing steel shall conform to ASTM Specification A615 (Grade 60).
 Structural Steel shall conform to ASTM Specification A36 unless noted otherwise.
 Stresses:
 Class "S" concrete $f'c = 3,500$ psi
 Grade 60 reinforcing steel $f_s = 24,000$ psi
 Materials:
 Anchor Bolts F1554, Grade 55
 Connecting Bolts F3125, Grade A325
 Mast Arm Vangs and End Plates A36
 Base Plates & Connecting Plates A36
 All bolts, nuts and washers shall be galvanized in accordance with the requirements of ASTM A153. All other steel shall be galvanized after fabrication in accordance with ASTM A123.
 Shop drawings and calculations shall be sealed by a Professional Engineer and submitted to the Engineer for review and approval prior to fabrication, in accordance with the requirements of the Standard Specifications.

All dimensions not shown on the plans are dependent on the manufacturer's design, and shall be shown on the shop drawings.
 Wind Loading: 90 MPH Velocity.

The single beam shall be designed for site conditions which are neither elevated above the average surrounding terrain by more than 30'-0 nor supported on a bridge.

Maximum Sign Area: $180 \text{ ft}^2 @ 5 \text{ lb/ft}^2$.

Tapered tubes shall conform to one of following: ASTM A36, ASTM A283, ASTM A1011, ASTM A595 Grade A, A572 Grade 65 or equivalent; and have a minimum yield of 50 ksi, 55 ksi, or 65 ksi after fabrication.

Support post and mast arms are not required to be of the same yield strength.

All high strength bolts shall be tightened in accordance with AISC Specifications (turn of nut method or calibrated wrench method) for Structural Joints issued by the Research Council on Riveted and Bolted Structural Joints unless noted otherwise.

Project Plans should provide an elevation view of each sign structure with location (station and offset), and sign panel layout and dimensions.

Horizontal members shall be pre-cambered for dead load deflection by manufacturer.

A minimum of 4 ASTM F1554 Grade 55 steel anchor bolts with hooks are required. Thread upper 10". Galvanize top 18" of bolts, and all nuts and washers.

Bolt hole diameters shall be equal to the bolt diameter + $1/8$ " unless noted otherwise

All signs shall be centered vertically between mast arms.

Dimensions shall not be scaled from drawings.

STANDARDS ENGINEER A. ALZUBI RECOMMENDED FOR APPROVAL GROUP MANAGER M. HANNA APPROVED STANDARDS COMMITTEE APPROVED FOR DISTRIBUTION	ARCHIVED	ARIZONA DEPARTMENT OF TRANSPORTATION INFRASTRUCTURE DELIVERY AND OPERATIONS DIVISION TRAFFIC SIGNING & MARKING STANDARD DRAWING	
		TAPERED TUBE SIGN STRUCTURE SINGLE BEAM	DRAWING NO. S-11 (1 of 2)