

NO	DESCRIPTION OF REVISIONS	DATE	MADE BY
1	RE-ISSUE	2/02	L. LOPEZ
2	CHANGED TOTAL SHEET NUMBER	6/08	L. LOPEZ
3	CHANGED TEXT CASE, REVISED NOTES AND CALLOUTS.		
4			

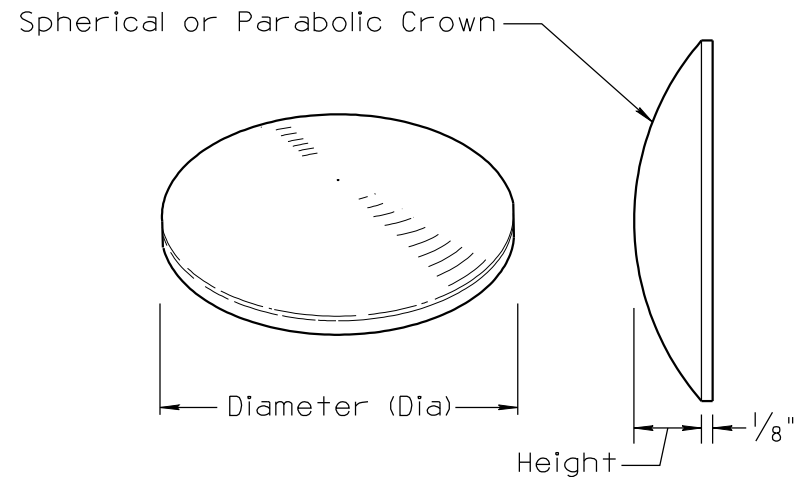

TYPES A, AY AND AB
(Types B and BY (Not Shown))

Marker Type	Dia	Height
A, AY & AB	4"	3/4" Max
B & BY	6"	1 3/4" Max

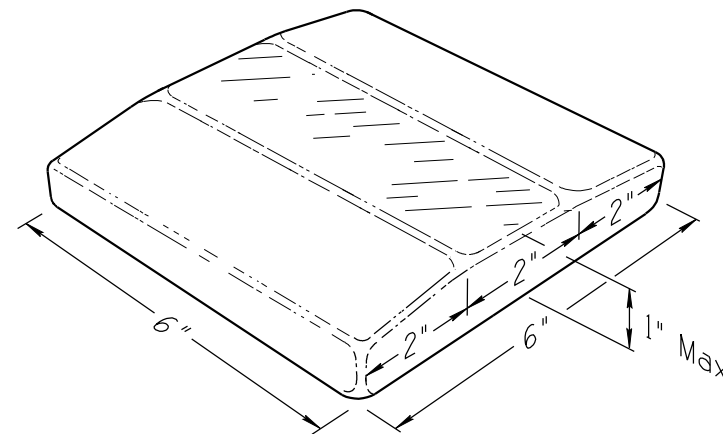

TYPES O AND OY JIGGLE BAR

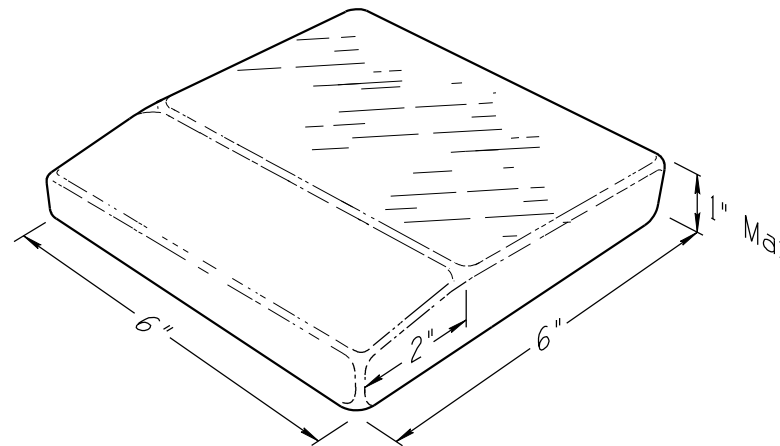
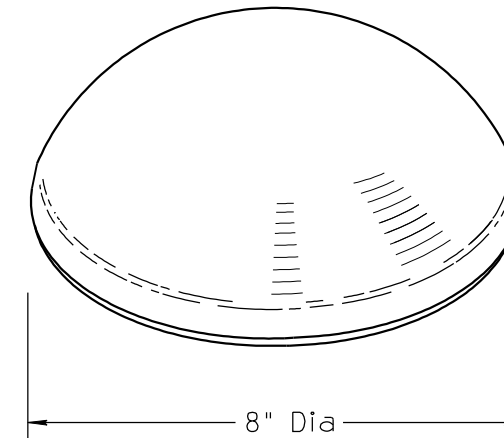

TYPES N AND NY JIGGLE BAR

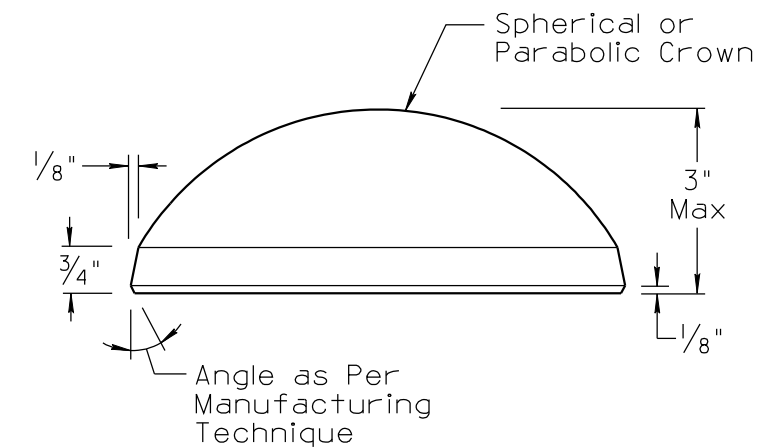

TYPES M AND MY,
(Large Channel Marker)

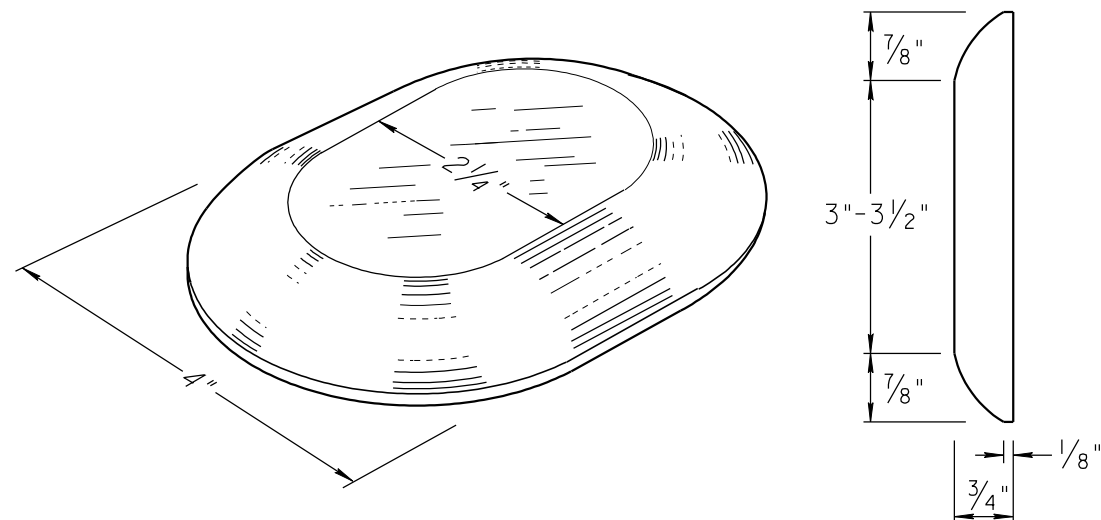

TYPES Q AND QY OVAL

NOTES:

1. See the Standard Specifications for additional requirements.
2. The height of jiggle bars can be reduced to 3/4 inch if called for on the plans.
3. All dimensions are nominal, except as otherwise noted.

NOT TO SCALE

DESIGN APPROVED	ARIZONA DEPARTMENT OF TRANSPORTATION INTERMODAL TRANSPORTATION DIVISION TRAFFIC SIGNING & MARKING STANDARD DRAWINGS	REVISION	6/14
SIGNATURES		DRAWING NO.	M-19
APPROVED FOR DISTRIBUTION	NON-REFLECTIVE RAISED PAVEMENT MARKER DETAILS	SHEET NO.	2 of 9
ON FILE			