

TOP VIEW

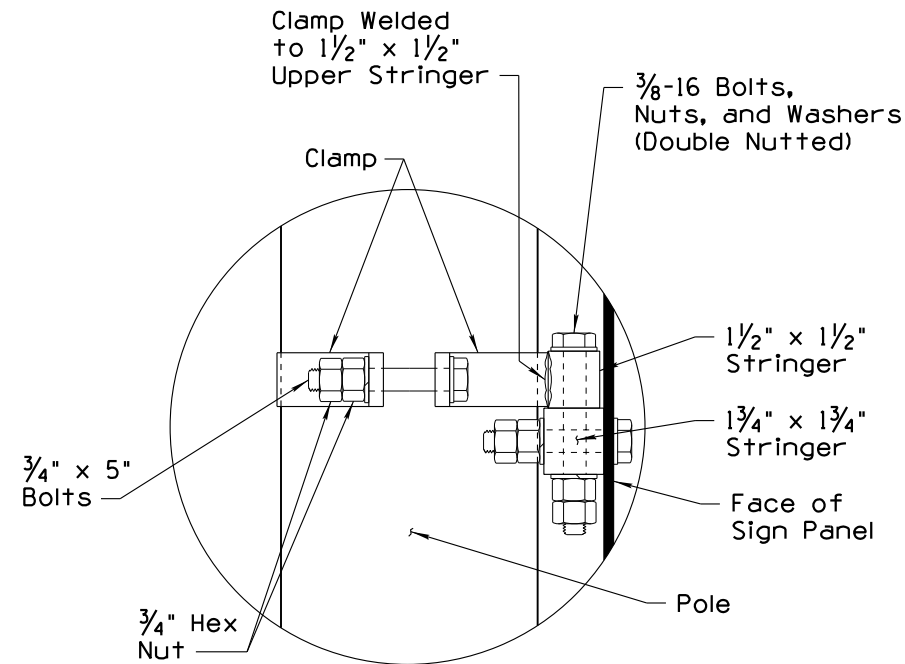

MOUNTING DETAIL

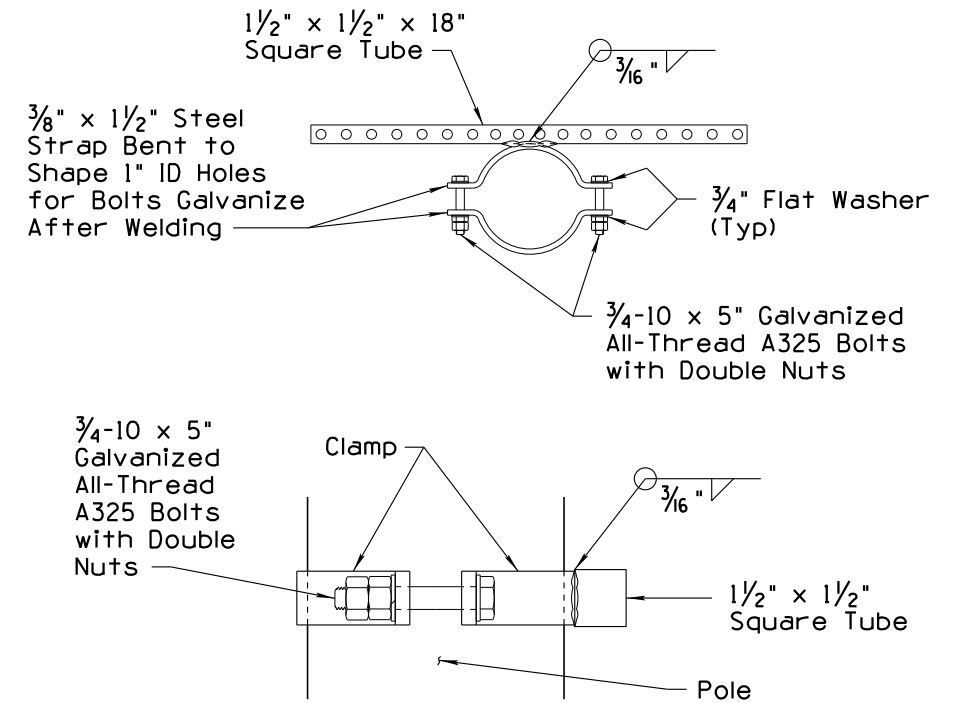

CLAMP DETAIL

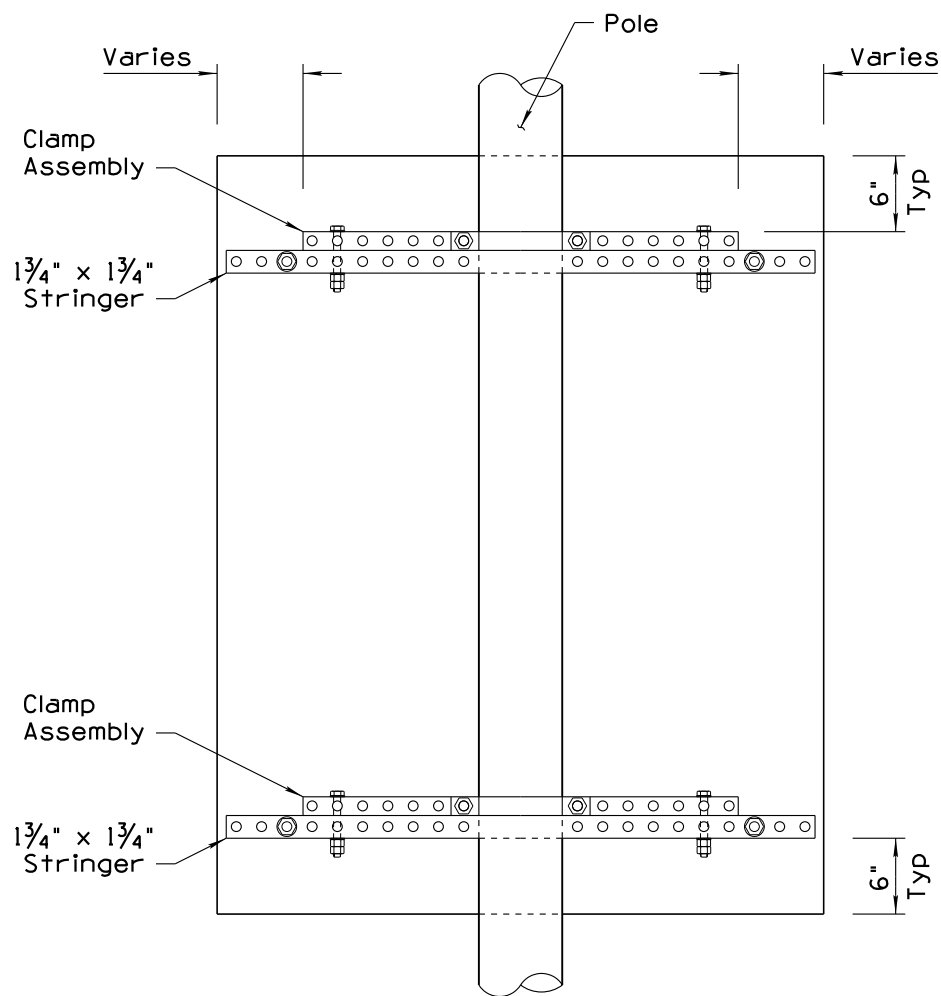

REAR VIEW

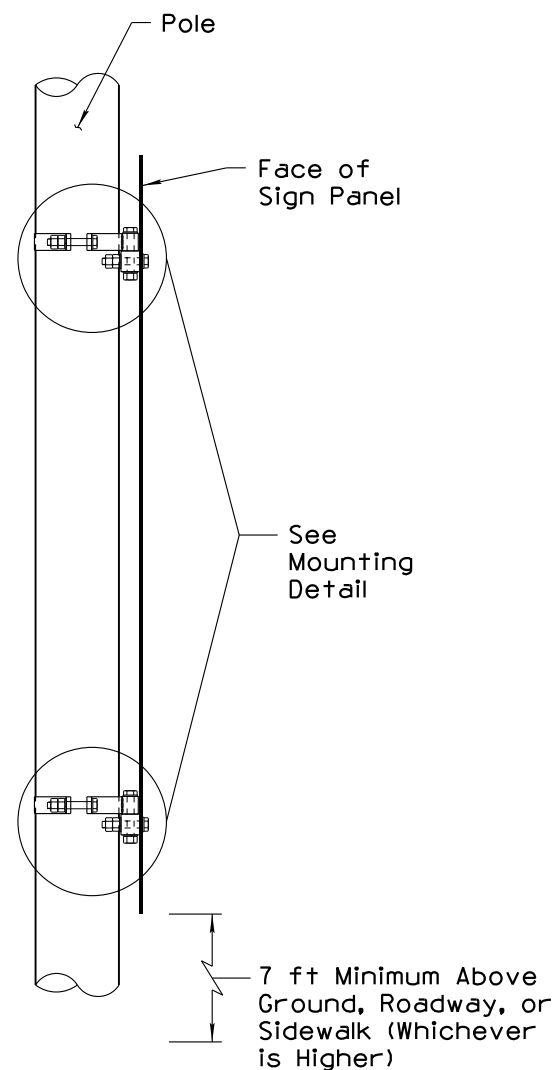

SIDE VIEW

NOTES:

1. All metal parts of the clamp assembly, including nuts, bolts, and washers, shall be galvanized. The clamp and square tube assembly shall be galvanized after fabrication and welding.
2. Clamp bolts shall be galvanized 3/4-10 all-thread A325 bolts with a minimum length of 5 inches. All clamp bolts shall use washers under the bolt head and bearing nut, and shall be double-nutted.
3. Standard clamp sizes, measured by nominal inside diameter: 4", 6", 8", 8"(U), 10" 12", 14", 16", 18", 20", 22", and 24". The 8"(U) clamp uses 10" bolts to fit an elliptical U pole.
4. All bolts used for connection of the clamp assembly to stringers shall use 3/8-16 plated bolts and washers. All bolts shall be double-nutted.
5. Signs or sign assemblies should be mounted centered on the pole or support if practical. If it is not practical to center the sign, stringers may be offset relative to the pole to accommodate sign mounting.
6. Clamping systems listed on the ADOT Approved Products List using a cable-type clamp may be substituted for standard clamps with the approval of the Engineer.

STANDARDS ENGINEER H. LUNA RECOMMENDED FOR APPROVAL GROUP MANAGER	ARIZONA DEPARTMENT OF TRANSPORTATION INFRASTRUCTURE DELIVERY AND OPERATIONS DIVISION TRAFFIC SIGNING & MARKING STANDARD DRAWING	
APPROVED M. HANNA	SIGN INSTALLATION ON POLE	DRAWING NO. S-9 1 of 4
STANDARDS COMMITTEE APPROVED FOR DISTRIBUTION	8/2022 DATE	

Note to Designer: The information presented in this Standard Drawing has been prepared in accordance with recognized engineering principles and is for general use. It should not be used for specific application without competent professional examination and verification of its suitability and applicability by a licensed professional engineer. Comments within the inner border line shall not be altered.

PRIOR DISTRIBUTION DATE
 6/2014