

NO	DATE	DESCRIPTION OF REVISIONS
1	6/14	ORIGINAL ISSUE
2		
3		
4		

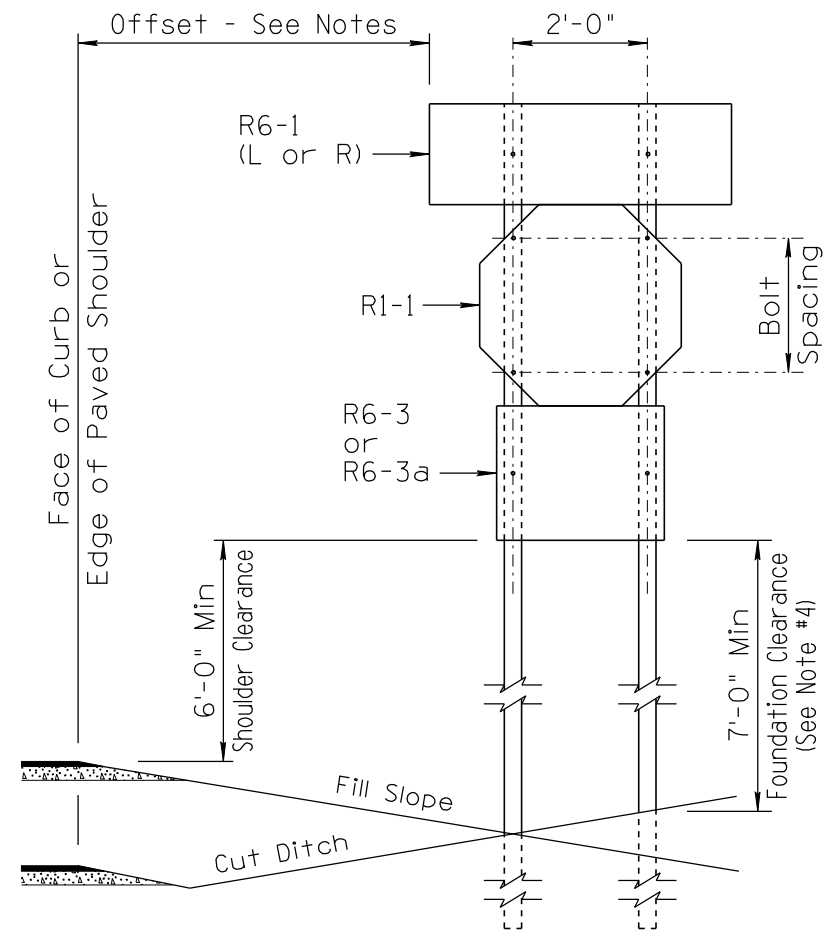

STOP / ONE WAY SIGN ASSEMBLY
FOR DIVIDED HIGHWAY INTERSECTIONS

Type	R6-1 Size (inches)	R1-1 Size (inches)	R6-3 Size (inches)	Post Type	Total Post Length (ft) (See Note 2)	Bolt Spacing (inches)
D1	36x12	30	30x24	2½T	30	24
D2	54x18	36	30x24	2½T ^f	33	24

f) May not be advisable for fill slopes 4:1 or greater, or offset greater than 12 ft or in special wind regions.

NOTES:

1. Sign offset is generally a minimum of 12 ft from edge of pavement to near edge of sign, but may be as close as 6 ft based on site conditions. Signs behind guardrail are generally placed 6 ft behind the face of guardrail. Lateral offset may be adjusted to improve visibility, to not obstruct other signs, or for other reasons. Signs generally should not be placed closer than 6 ft from the edge of paved shoulder or face of curb, except on urban streets where such an offset is impractical, in which case an offset of as small as 2 ft may be used.
2. Post lengths in tables are for estimating purposes only. Post lengths will be determined in field at the sign location to satisfy minimum mounting height requirements. Actual post length will vary depending on offset, ground slope and other factors.
3. Calculations in table are based on a 12 ft offset from near edge of sign to edge of pavement and a 6:1 fill slope. Different offsets or slopes may affect post type and length.
4. The foundation clearance may be reduced if the shoulder clearance is greater than 10 ft and the sign does not overhang any sidewalk or pedestrian path.

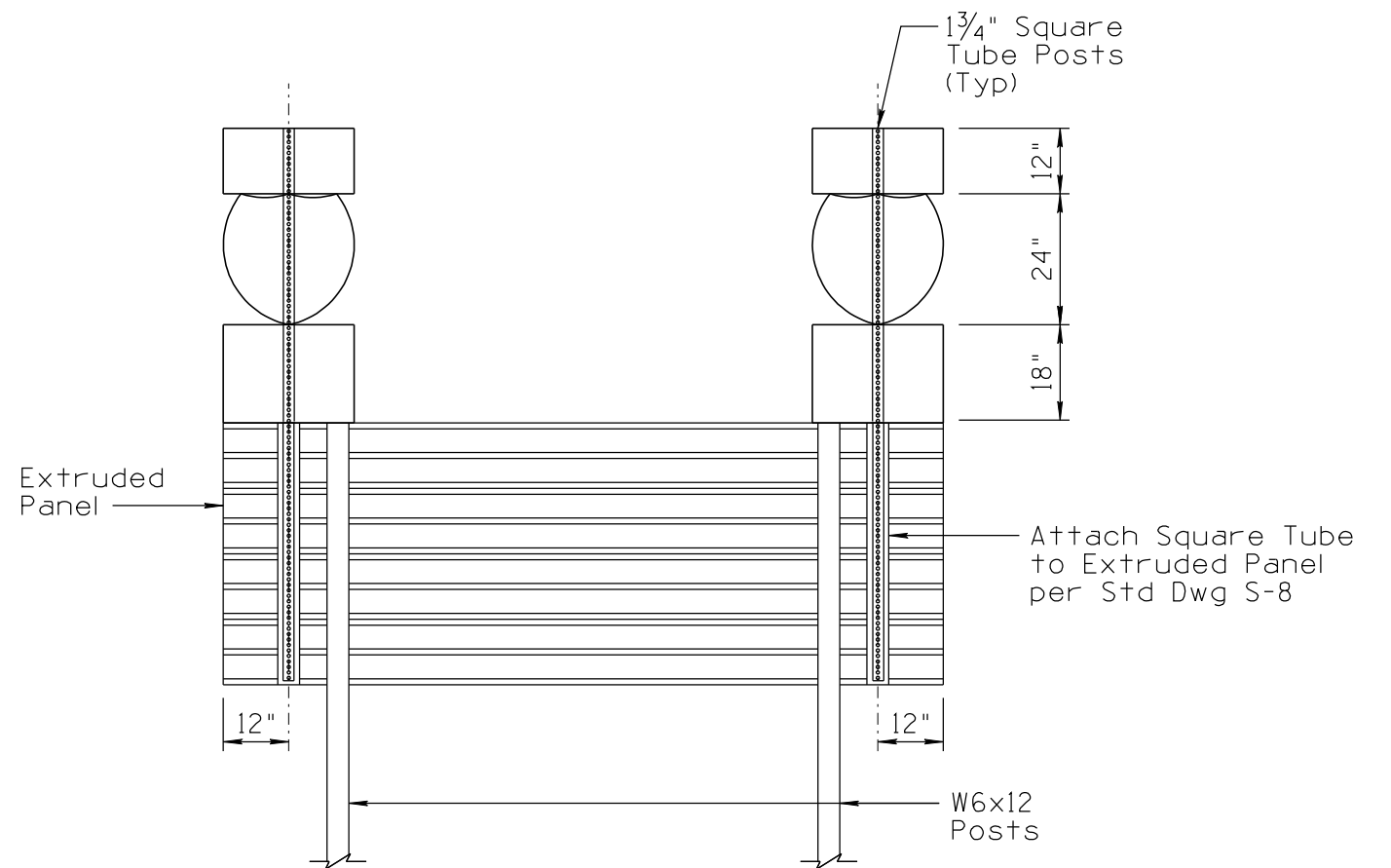

COMBINATION ROUTE MARKER/DESTINATION ASSEMBLY
Rear View

NOT TO SCALE

DESIGN APPROVED	ARIZONA DEPARTMENT OF TRANSPORTATION INTERMODAL TRANSPORTATION DIVISION TRAFFIC SIGNING & MARKING STANDARD DRAWINGS	REVISION 6/14
SIGNATURES		DRAWING NO. S-3
APPROVED FOR DISTRIBUTION	ON FILE	SHEET NO. 13 of 16
	SPECIAL SIGN ASSEMBLIES	