

NO	DATE	DESCRIPTION OF REVISIONS
1	6/14	ORIGINAL ISSUE
2		
3		
4		

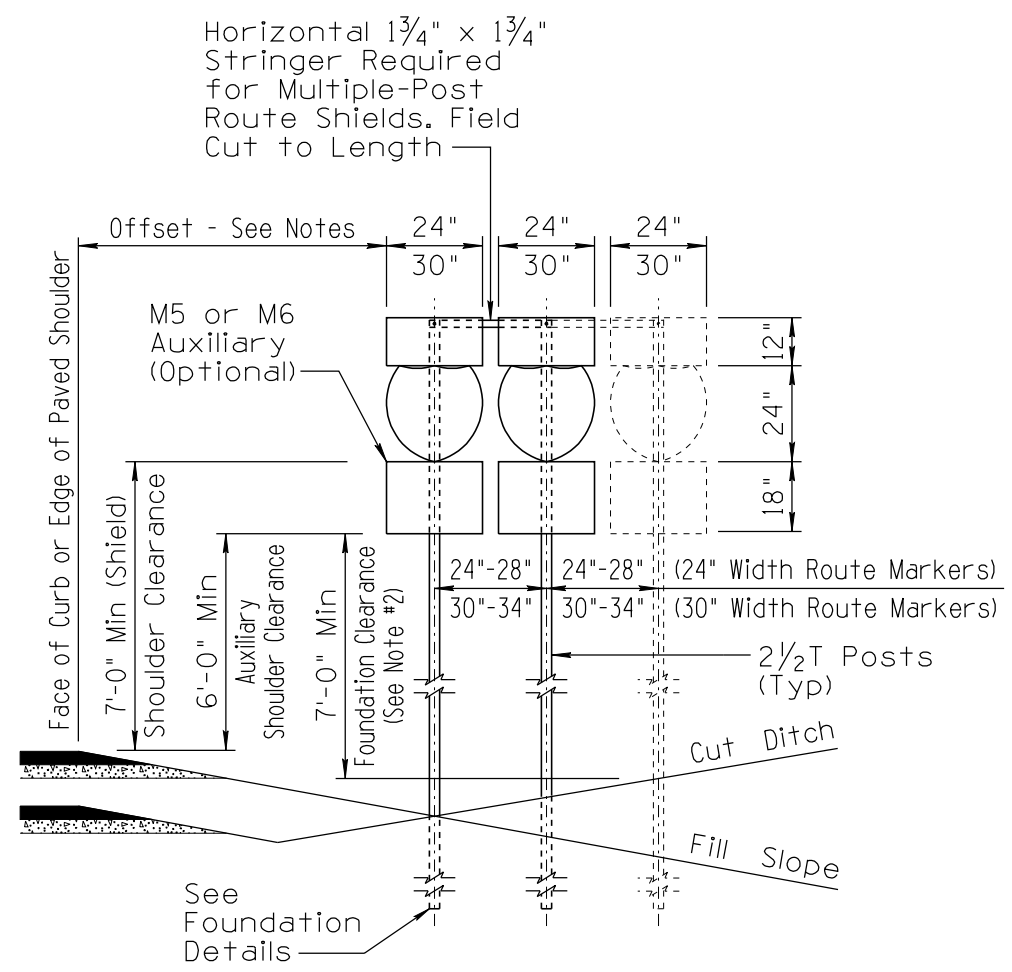

MULTIPLE ROUTE MARKER
 Conventional Road
 (Including Freeway Ramp or Crossroad)
 24 and 30 Inch Width Route Markers

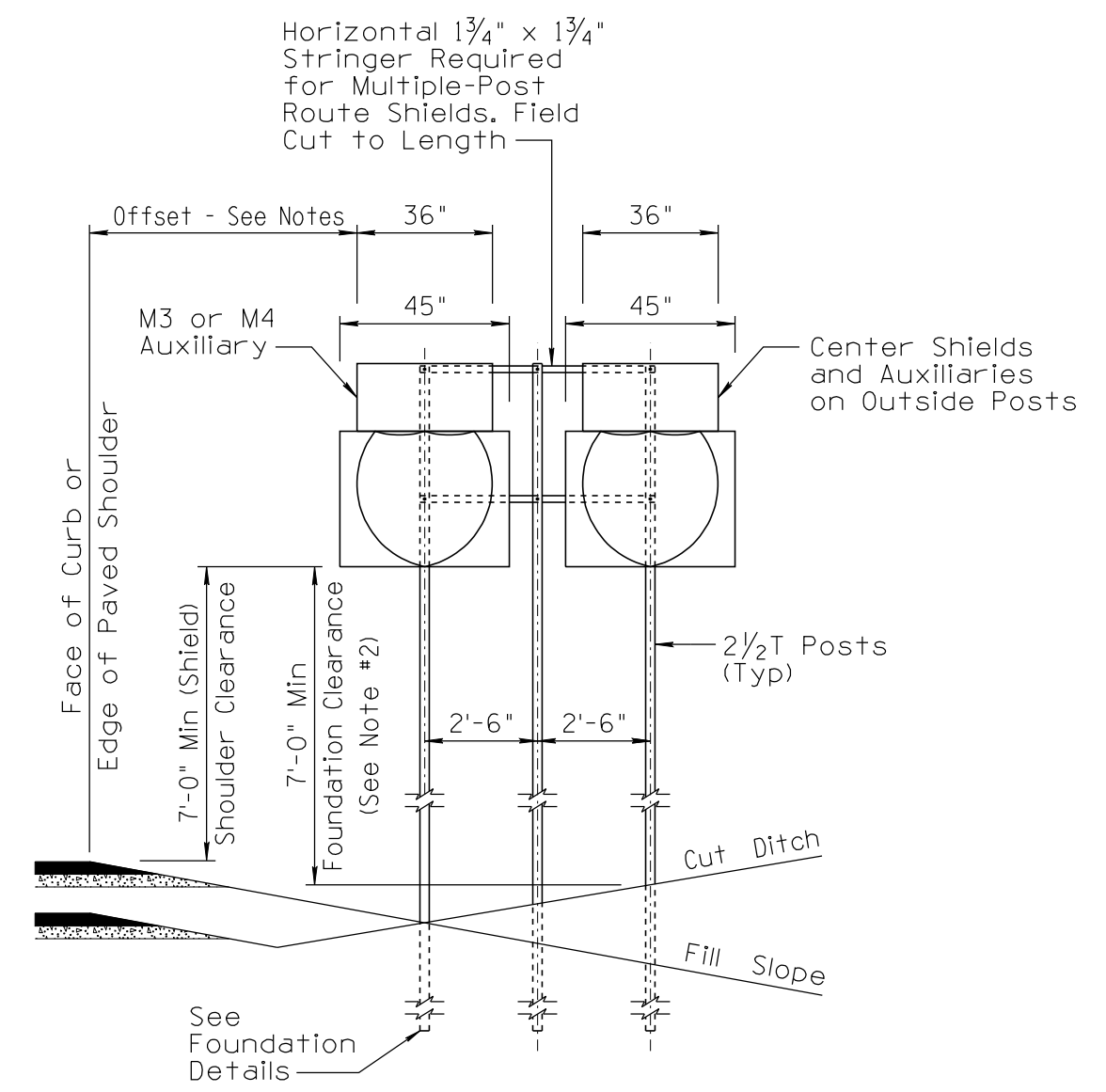

MULTIPLE ROUTE MARKER
 Freeway or Expressway Mainline
 36 and 45 Inch Width Route Markers

NOTE:

1. Sign offset is generally a minimum of 12 ft from edge of pavement to near edge of sign, but may be as close as 6 ft based on site conditions. Signs behind guardrail are generally placed 6 ft behind the face of guardrail. Lateral offset may be adjusted to improve visibility, to not obstruct other signs, or for other reasons. Signs generally should not be placed closer than 6 ft from the edge of paved shoulder or face of curb, except on urban streets where such an offset is impractical, in which case an offset of as small as 2 ft may be used.
2. The foundation clearance may be reduced if the shoulder clearance is greater than 10 ft and the sign does not overhang any sidewalk or pedestrian path.

NOT TO SCALE

DESIGN APPROVED	ARIZONA DEPARTMENT OF TRANSPORTATION INTERMODAL TRANSPORTATION DIVISION TRAFFIC SIGNING & MARKING STANDARD DRAWINGS	REVISION	6/14
SIGNATURES		DRAWING NO.	S-3
APPROVED FOR DISTRIBUTION	MULTIPLE ROUTE MARKER ASSEMBLIES	SHEET NO.	12 of 16
ON FILE			