

Note to Designer: The information presented in this Standard Drawing has been prepared in accordance with recognized engineering principles and is for general use. It should not be used for specific application without competent professional examination and verification of its suitability and applicability by a licensed professional engineer. Contents within the inner border line shall not be altered.

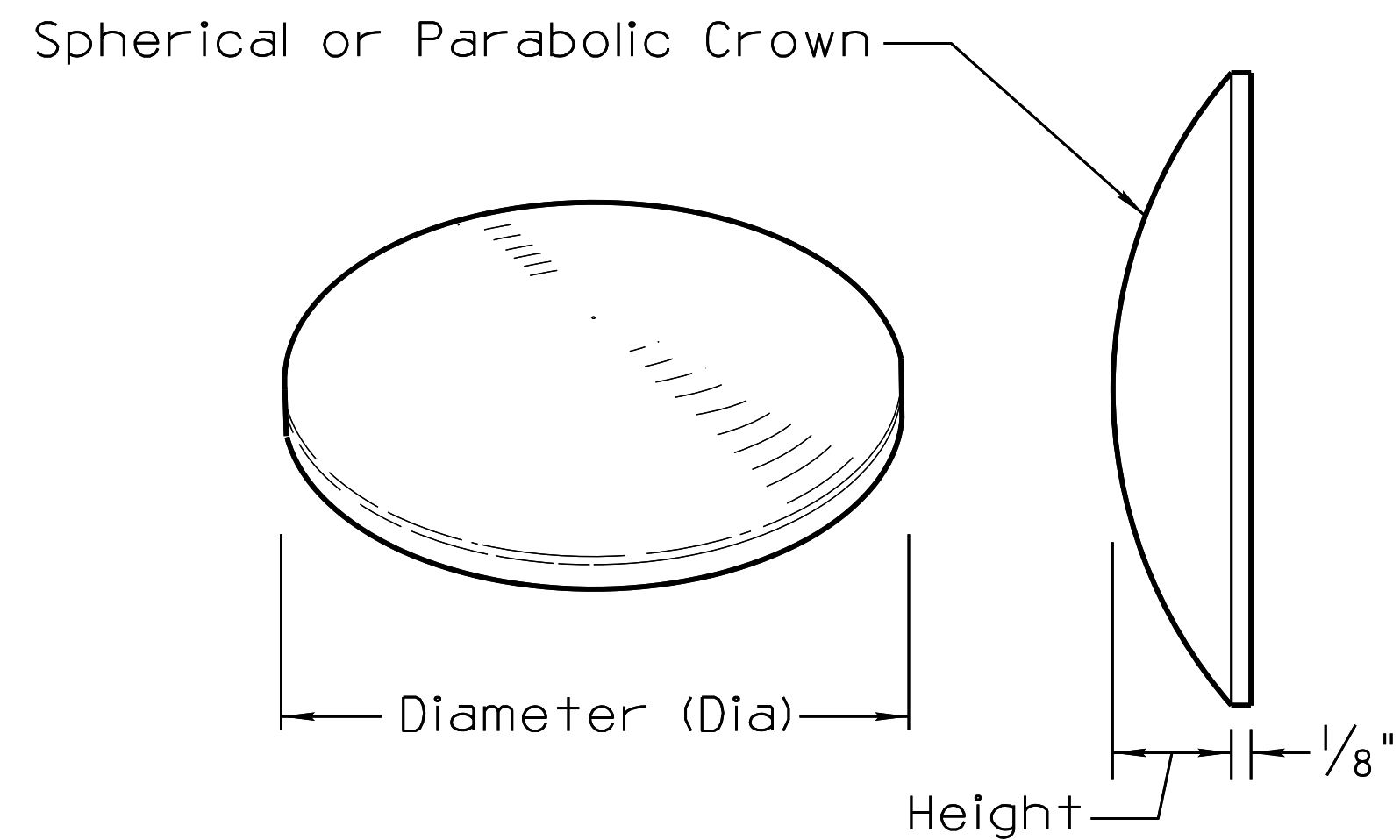

**TYPES A, AY AND AB**

(Types B and BY (Not Shown))

Marker Type	Dia	Height
A, AY & AB	4"	3/4" Max
B & BY	6"	1 3/4" Max

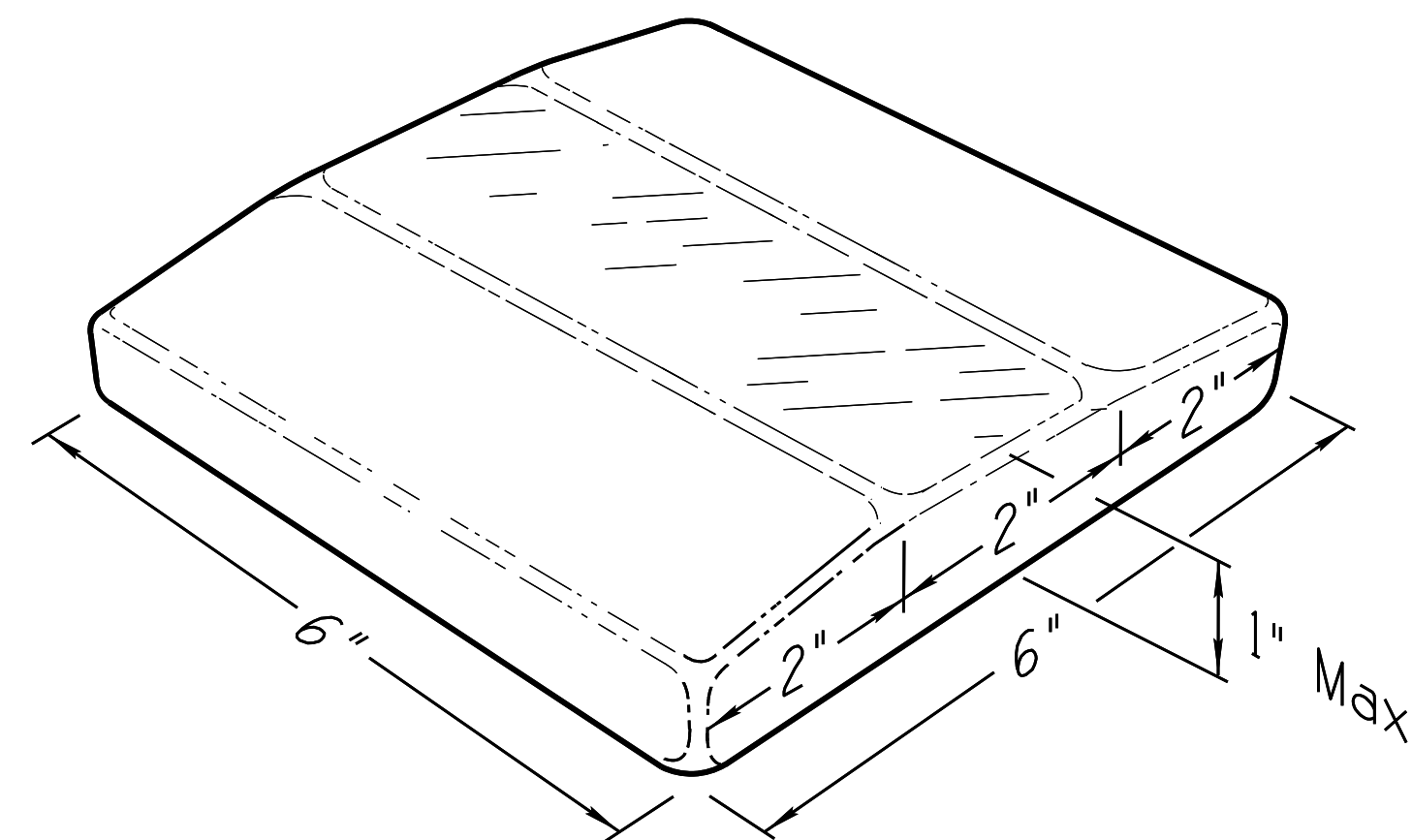

**TYPES O AND OY JIGGLE BAR**

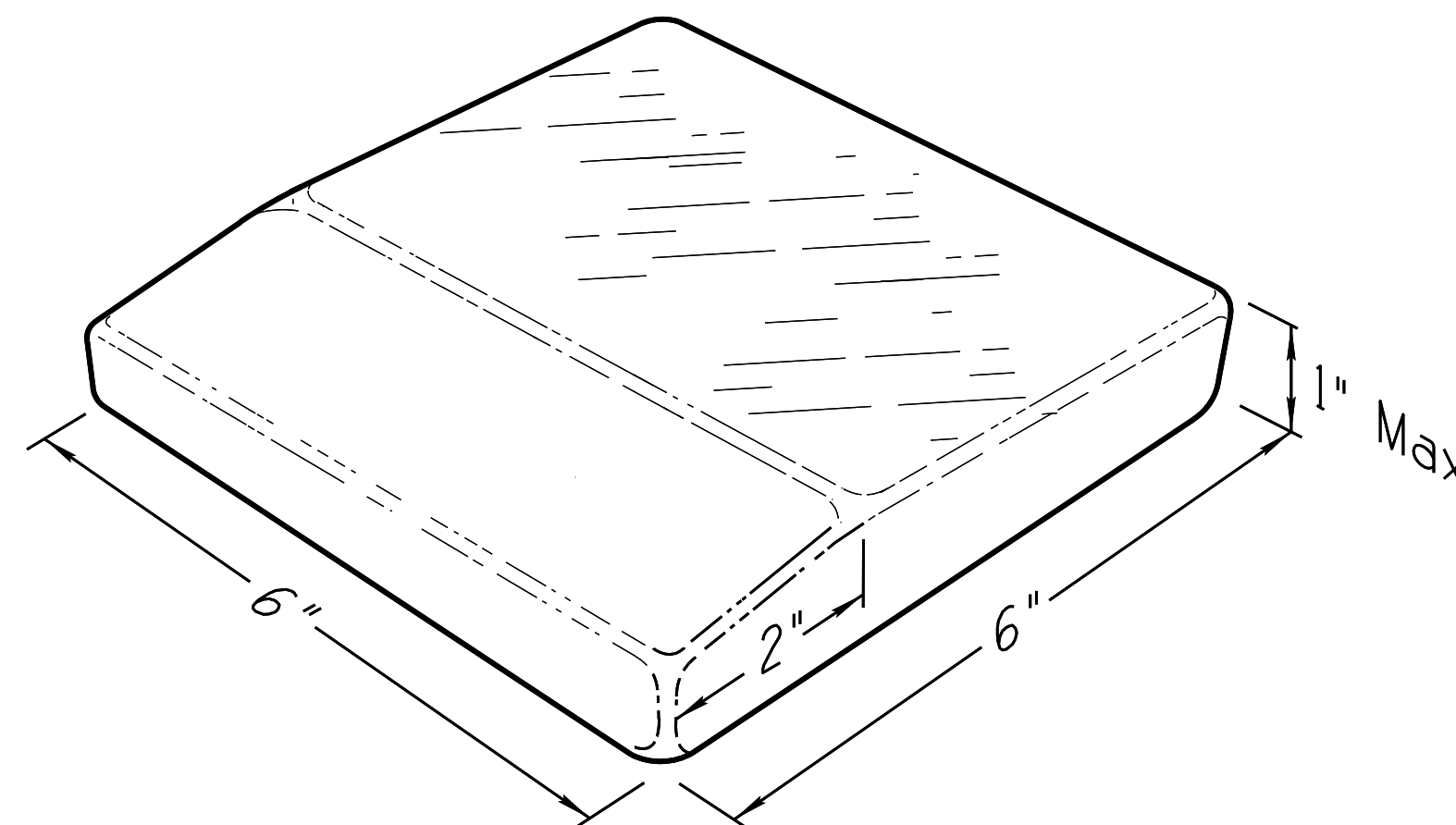

**TYPES N AND NY JIGGLE BAR**

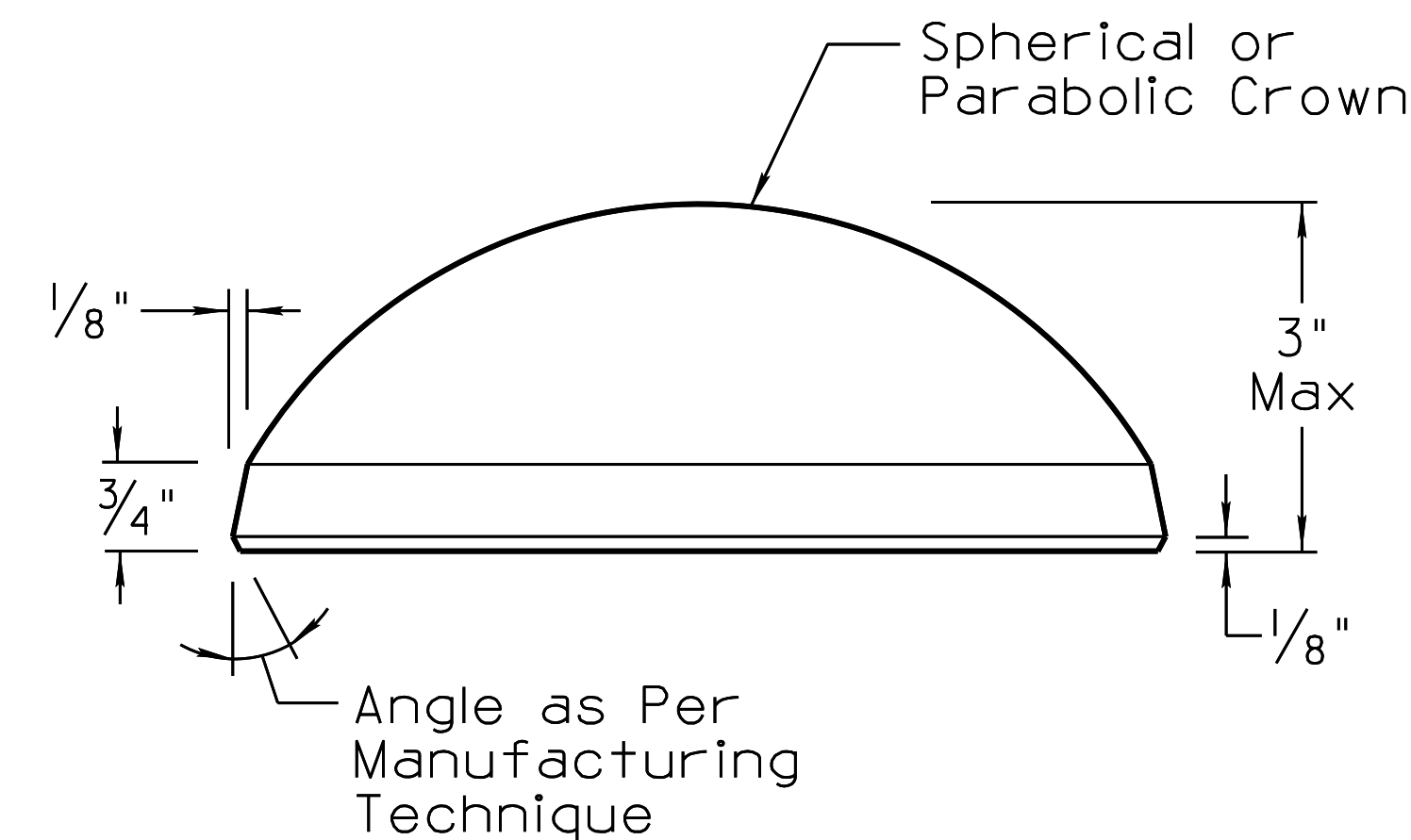
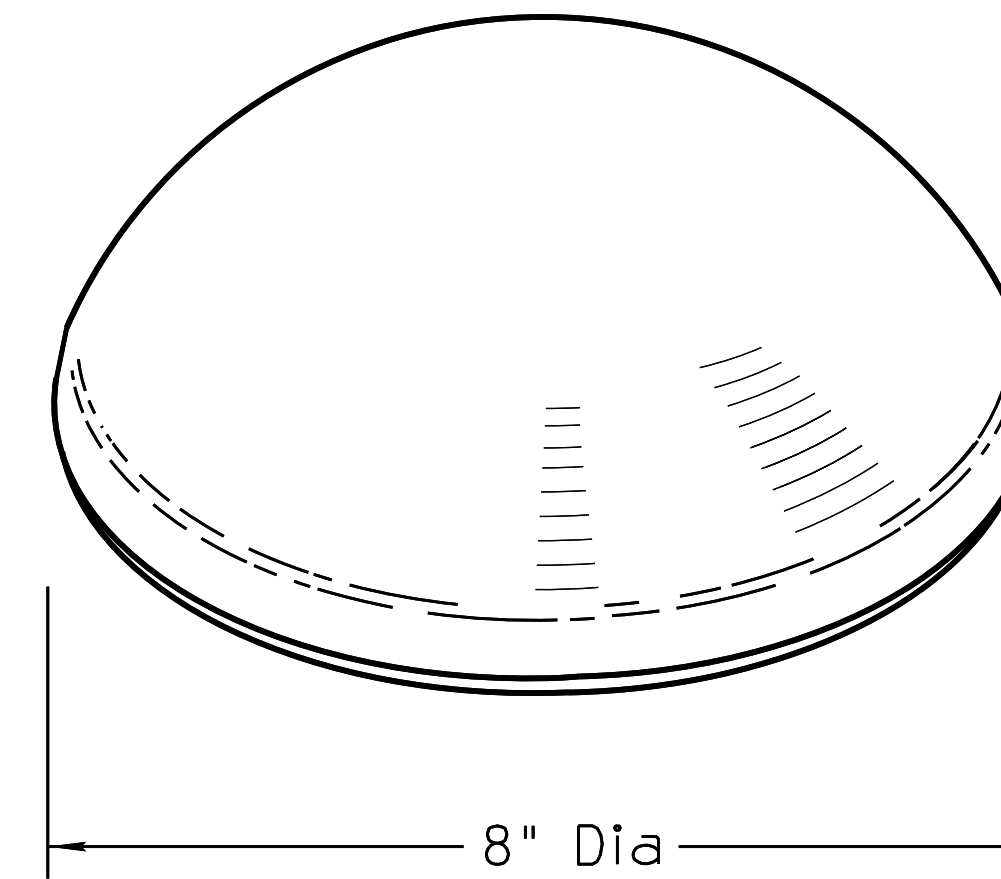

**TYPES M AND MY,  
(Large Channel Marker)**

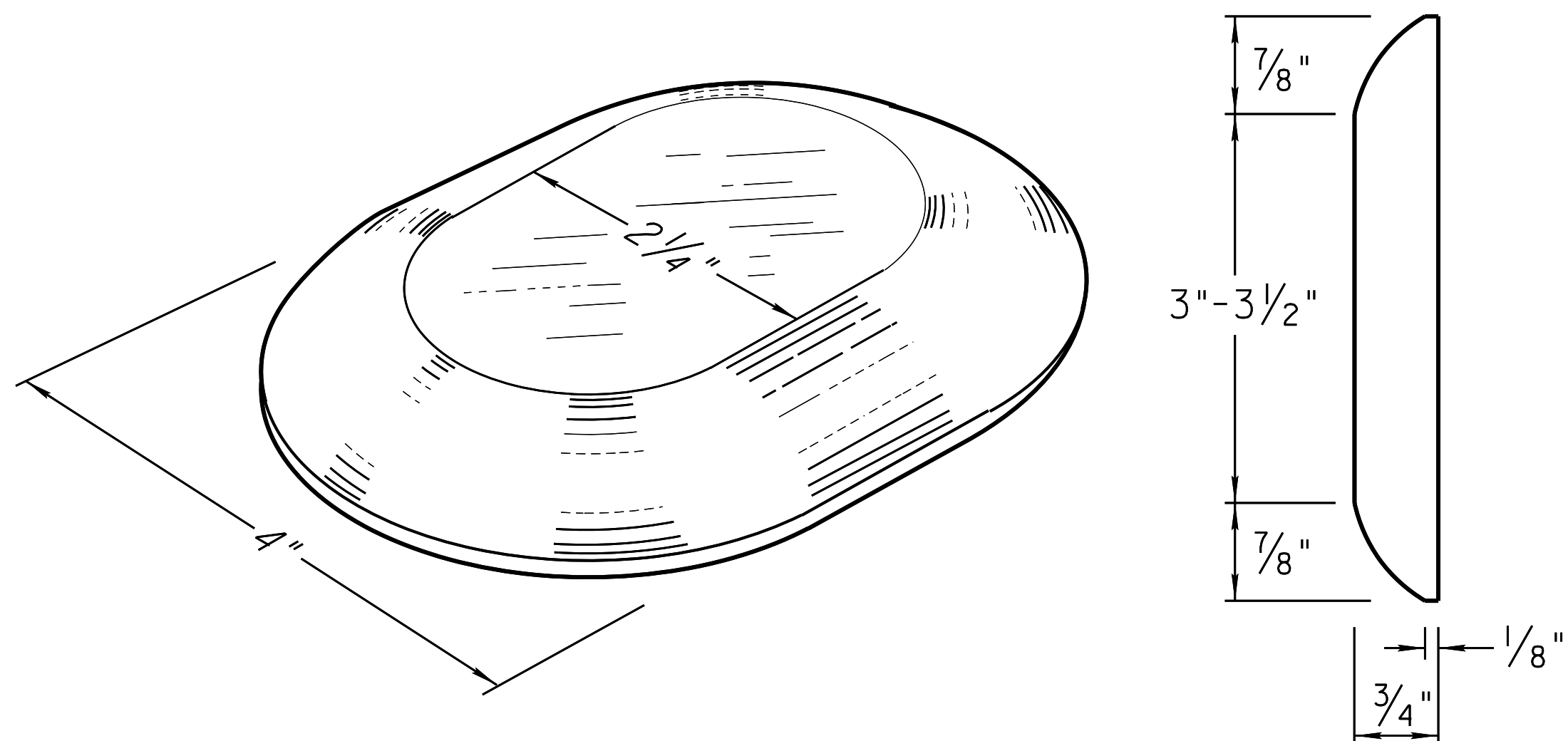

**TYPES Q AND QY OVAL**

**NOTES:**

1. See the Standard Specifications for additional requirements.
2. The height of jiggle bars can be reduced to 3/4 inch if called for on the plans.
3. All dimensions are nominal, except as otherwise noted.

06/2008

PRIOR DISTRIBUTION DATE

STANDARDS ENGINEER <b>R. MOEUR</b>	ARIZONA DEPARTMENT OF TRANSPORTATION INFRASTRUCTURE DELIVERY AND OPERATIONS DIVISION TRAFFIC SIGNING AND MARKING STANDARD DRAWINGS	
RECOMMENDED FOR APPROVAL GROUP MANAGER <b>M. HANNA</b>	NON-REFLECTIVE RAISED PAVEMENT MARKERS DETAILS	DRAWING NO. <b>M-19</b>
APPROVED STANDARDS COMMITTEE APPROVED FOR DISTRIBUTION DATE: 06/2014		Sheet 2 of 11