

NO.	DESCRIPTION OF REVISIONS	MADE BY	DATE
1	RE-ISSUE	L. LOPEZ	2/02
2	REVISED SIGN DIMENSIONS, ADDED TWO NEW DRAWINGS, ADDED NEW BORDER.	L. LOPEZ	10/10
3			
4			

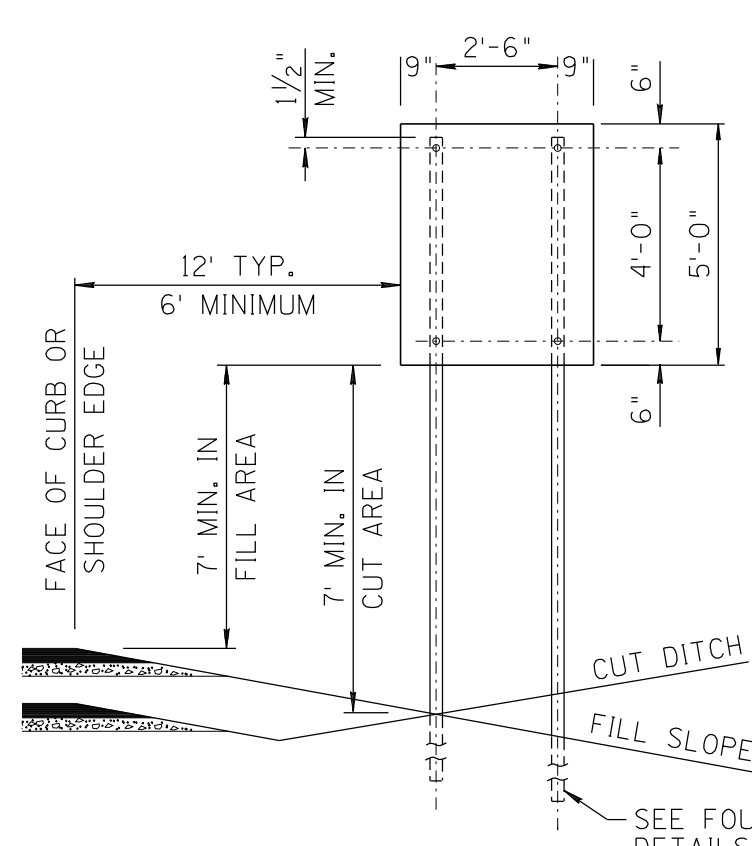

REGULATORY SIGN

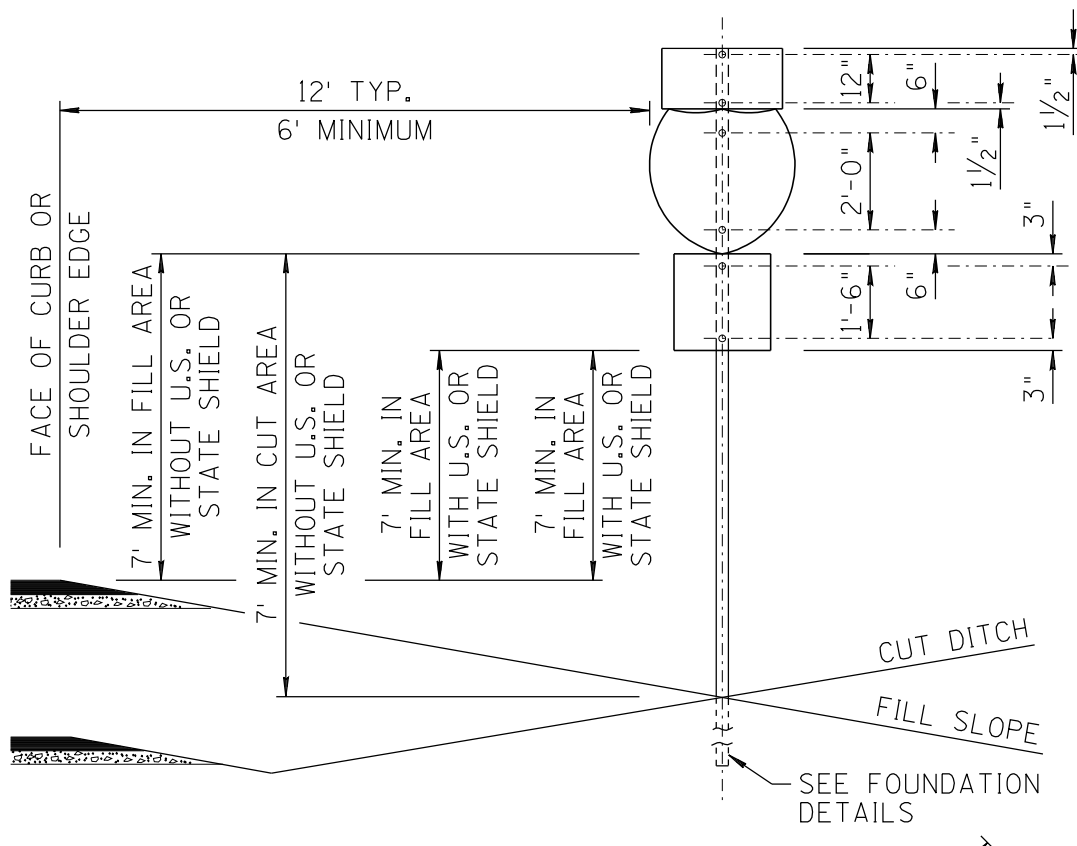

ROUTE MARKER ASSEMBLY

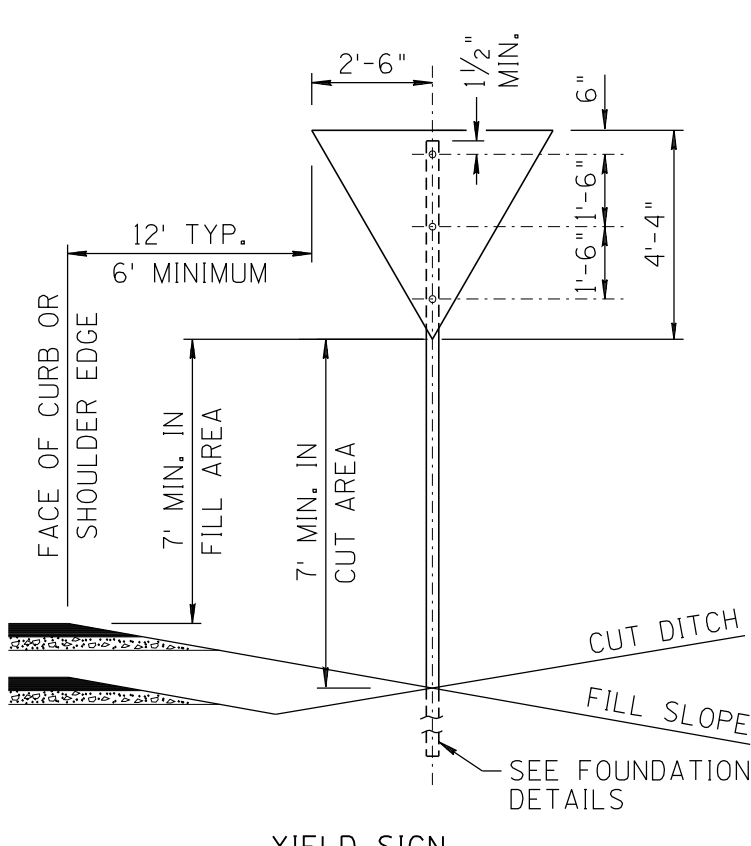

YIELD SIGN

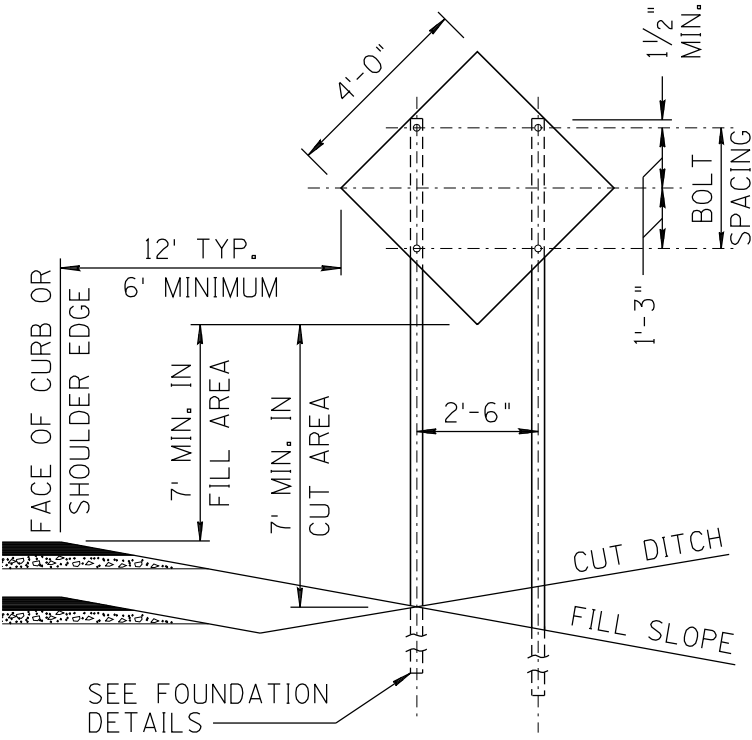

WARNING SIGN
WITHOUT PLAQUE

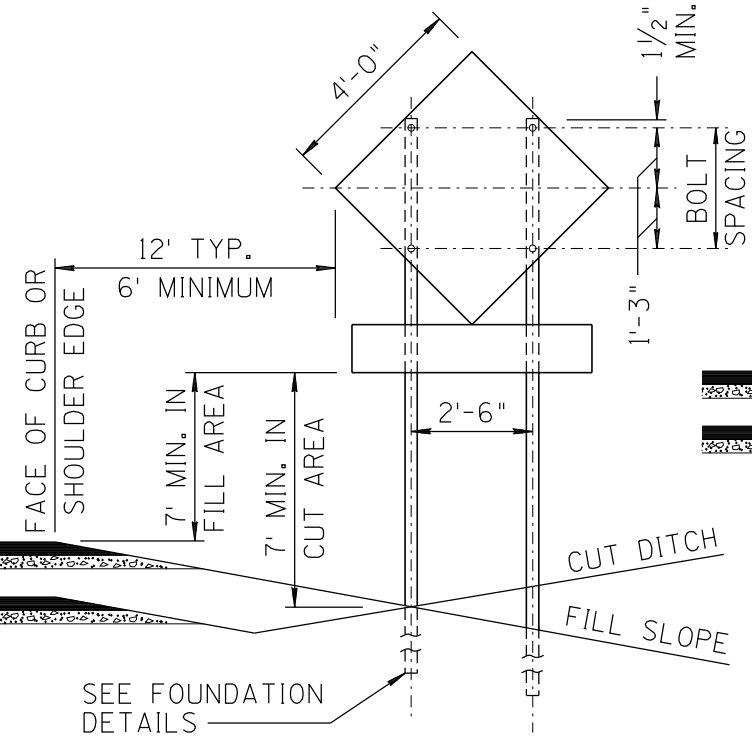

WARNING SIGN
WITH SMALL AUXILIARY PLAQUE
(LESS THAN 8 SQUARE FEET)

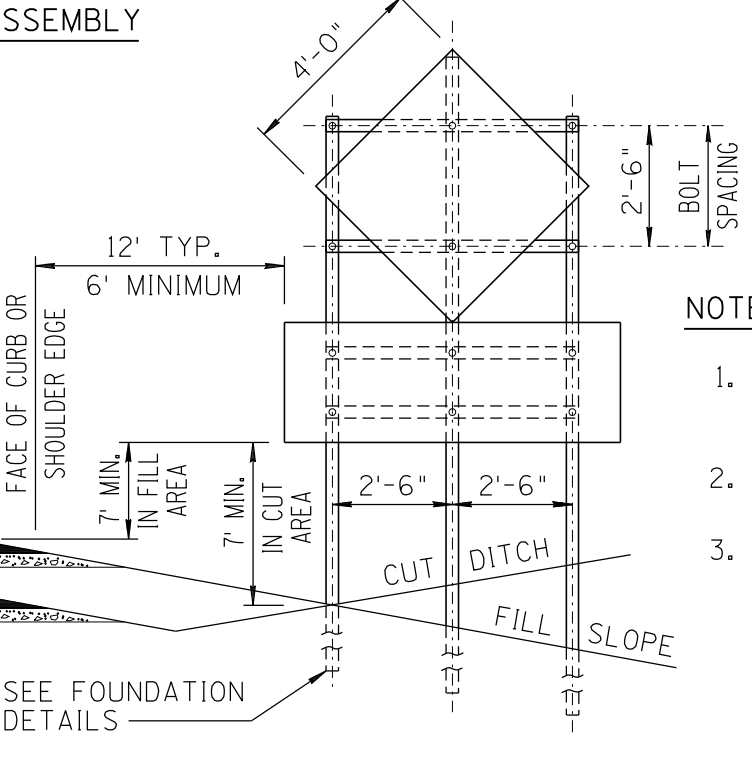

WARNING SIGN
WITH LARGE AUXILIARY PLAQUE
(8 SQUARE FEET OR MORE)

NOTES:

1. SEE FHWA STANDARD HIGHWAY SIGNS BOOKLET FOR PANEL BOLT HOLE SPACING NOT SHOWN.
2. DETERMINE POST SIZE FROM SQUARE TUBE SELECTION CHART.
3. OFFSET FROM FACE OF CURB OR SHOULDER EDGE MAY BE ADJUSTED DUE TO FIELD CONDITIONS.

DESIGN APPROVED	ARIZONA DEPARTMENT OF TRANSPORTATION INTERMODAL TRANSPORTATION DIVISION TRAFFIC SIGNING & MARKING STANDARD DRAWINGS	REVISION	10/10
APPROVED FOR DISTRIBUTION		DRAWING NO.	S-3
OFFSETS, CLEARANCES AND MOUNTING DETAILS FOR WARNING, REGULATORY AND MARKER SIGNS ON FREEWAYS		SHEET NO.	2 OF 4

NOT TO SCALE