

NO	DESCRIPTION OF REVISIONS	MADE BY	DATE
1	RE-ISSUE	L. LOPEZ	2/02
2	RE-DRAWN	M.Z. / L.L.	5/03
3			
4			

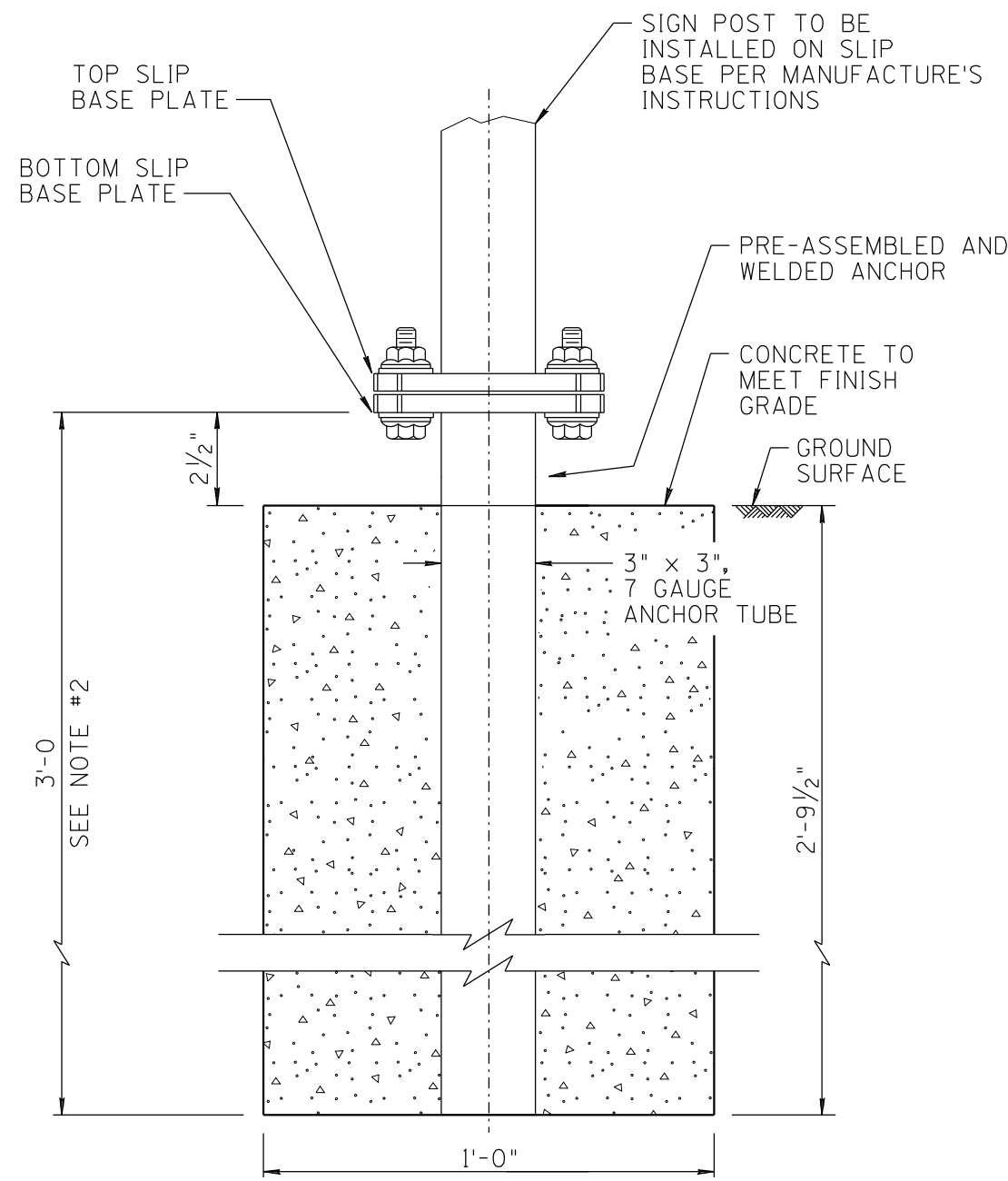

FOUNDATION DETAILS
 PRE-ASSEMBLED SLIP BASE UNIT.
 EXACT CONFIGURATION VARIES.
 CONTACT MANUFACTURER ON ADOT
 APPROVED PRODUCT LIST FOR
 INFORMATION AND REQUIREMENTS.

NOTES:

1. ALL SLIP BASES SHALL BE PRE-ASSEMBLED BY THE MANUFACTURER. THE SLIP BASE SHALL BE INSTALLED ACCORDING TO THE MANUFACTURER'S INSTRUCTIONS.
2. ANCHOR TUBE AND BOTTOM SLIP BASE SHALL BE WELDED TOGETHER INTO A ONE-PIECE ASSEMBLY INSTALLED IN THE FOUNDATION.

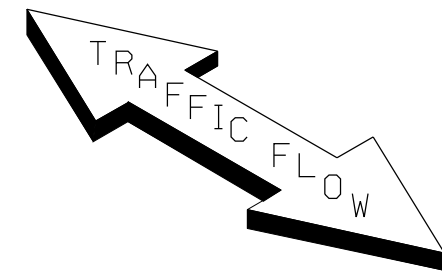
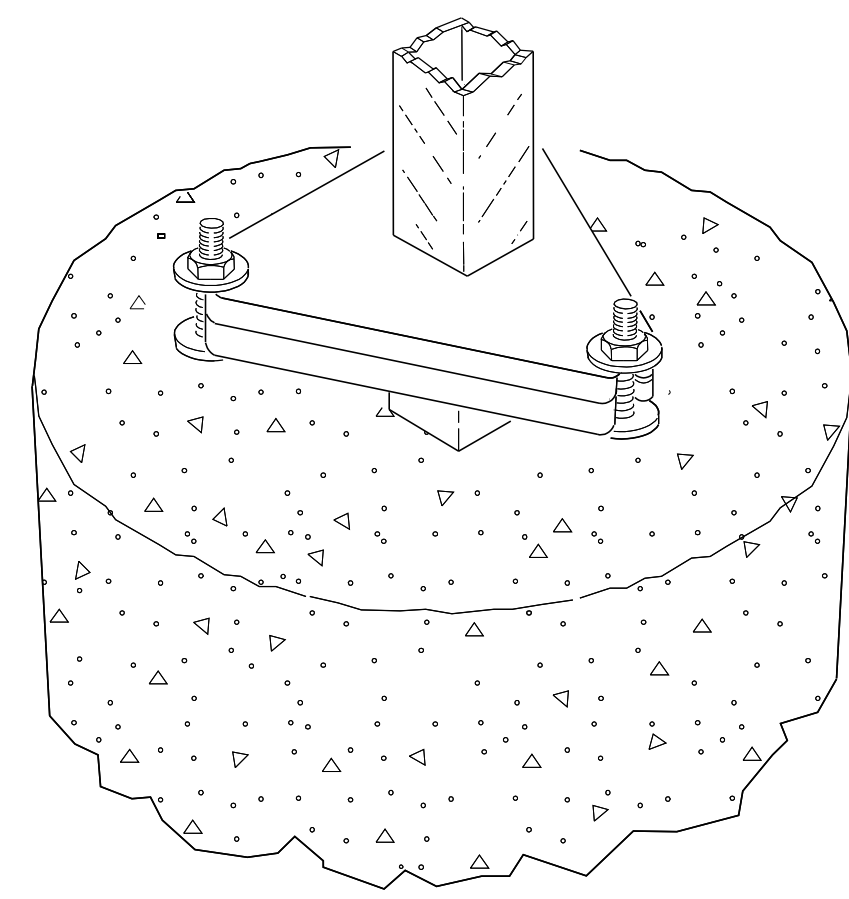

SHEET 3 OF 3
 NOT TO SCALE

DESIGN APPROVED	ARIZONA DEPARTMENT OF TRANSPORTATION INTERMODAL TRANSPORTATION DIVISION STANDARD DRAWINGS	REV.
ARCHIVED		5/03
APPROVED FOR DISTRIBUTION	PERFORATED SIGN POST FOUNDATION	DRAWING NO. S-1