

NO	DESCRIPTION OF REVISIONS	MADE BY	DATE	NO
1	ORIGINAL ISSUE	CC & LL	7/09	3
2	REMOVED REINFORCING SLEEVE FROM "FINAL ASSEMBLY" DETAIL, EDIT CALL OUTS	L. LOPEZ	1/10	4
	DESCRIPTION OF REVISIONS	MADE BY	DATE	

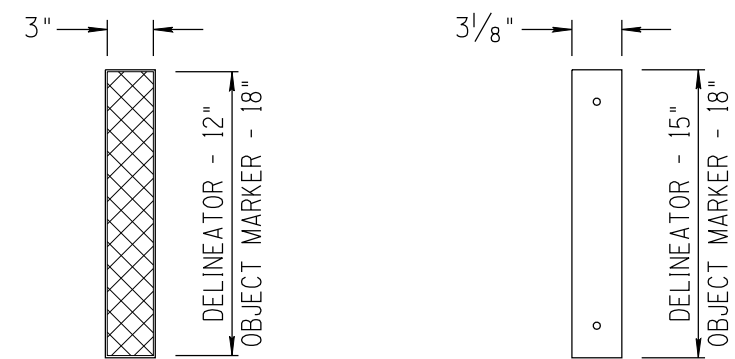

REFLECTOR
REFLECTIVE PANEL (PRE-DRILLED/PUNCHED)
(OR AS DETAILED ON OTHER PLANS)

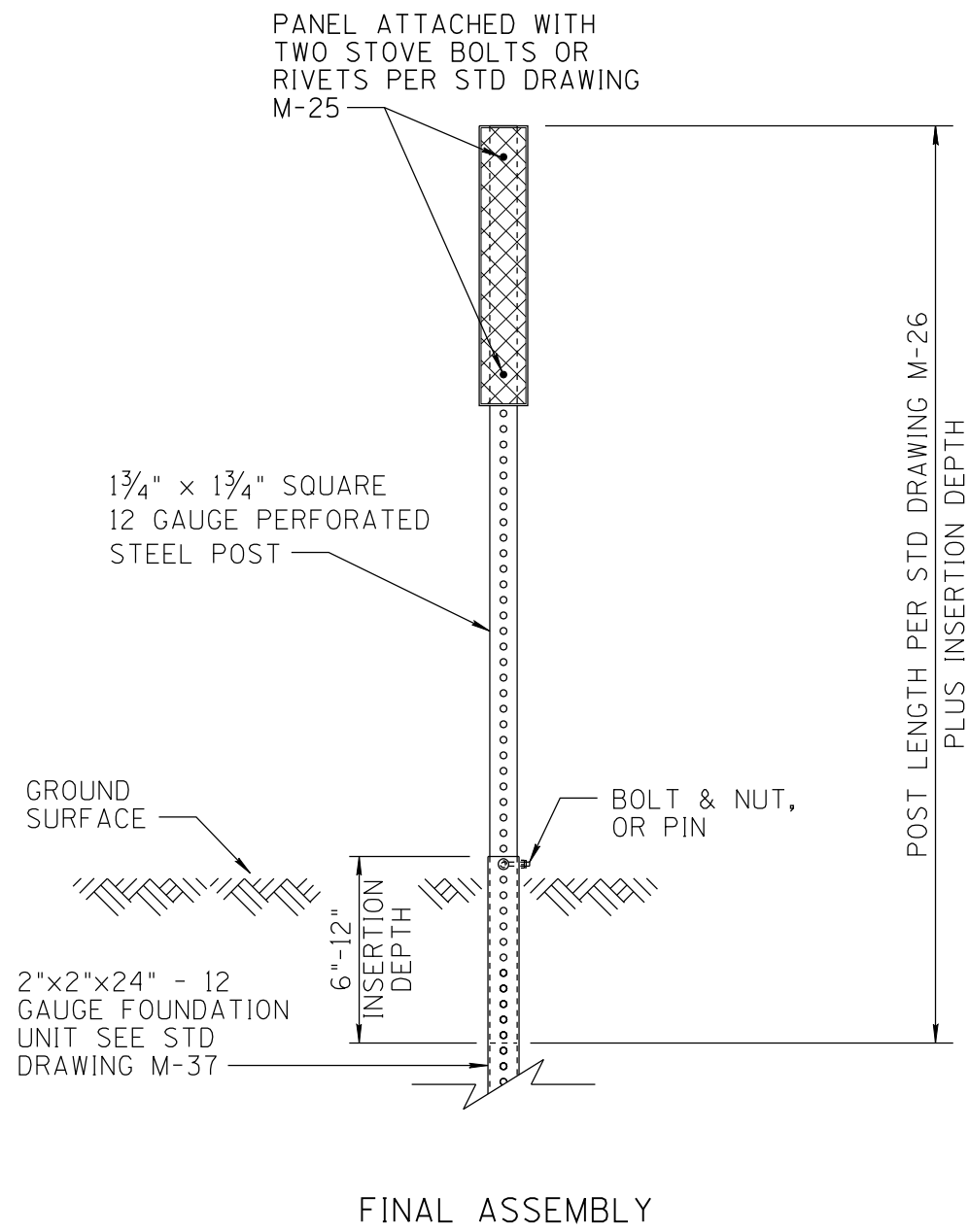
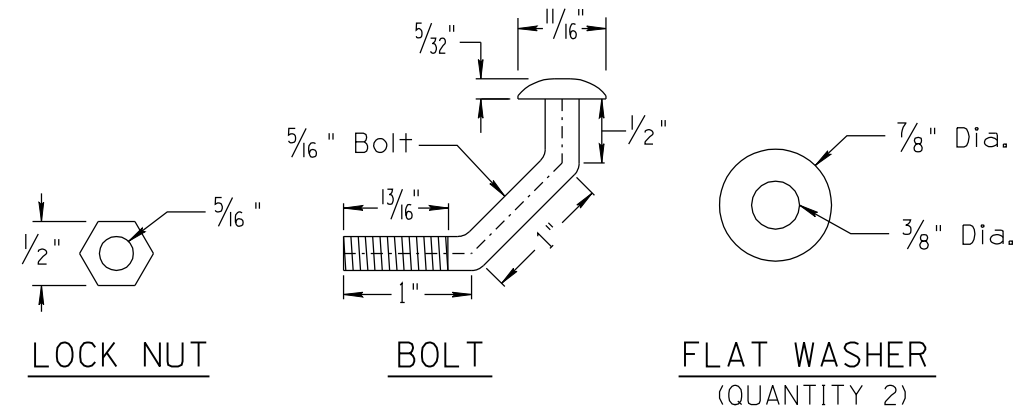

NOT TO SCALE

DESIGN APPROVED	ARIZONA DEPARTMENT OF TRANSPORTATION INTERMODAL TRANSPORTATION DIVISION TRAFFIC SIGNING & MARKING STANDARD DRAWINGS	REVISION 1/10
APPROVED FOR DISTRIBUTION		DRAWING NO. M-38
SQUARE STEEL POST BREAK-AWAY DELINEATOR		SHEET NO. 1 OF 1