

NO	DESCRIPTION OF REVISIONS	MADE BY	DATE
1	RE-ISSUE	L. LOPEZ	2/02
2	RUMBLE STRIP PATTERN CHANGE.	L. LOPEZ	5/03
3	RUMBLE STRIP PATTERN CHANGE.	L. LOPEZ	11/07
4	EDIT NOTES	L. LOPEZ	9/08

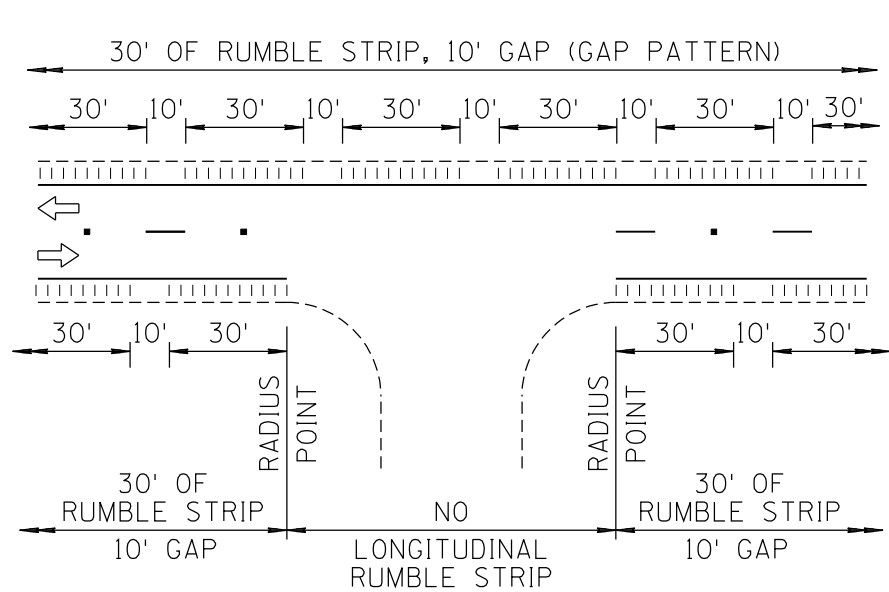

INSTALLATION ON HIGHWAYS WITH UNDIVIDED TWO-WAY TRAFFIC AND NO ACCESS CONTROL

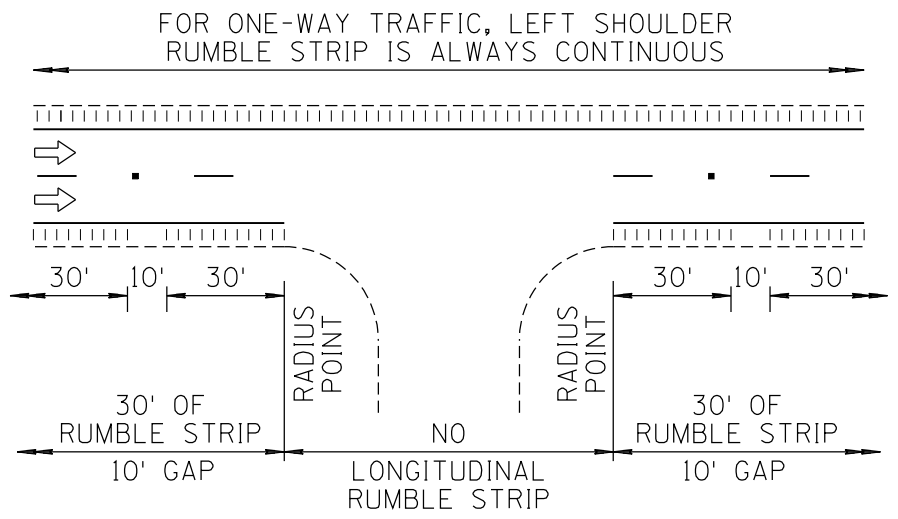

TYPICAL DIVIDED ONE-WAY TRAFFIC AND HEAVY USE DRIVEWAY OR CROSSROAD EXCEPTION DETAIL

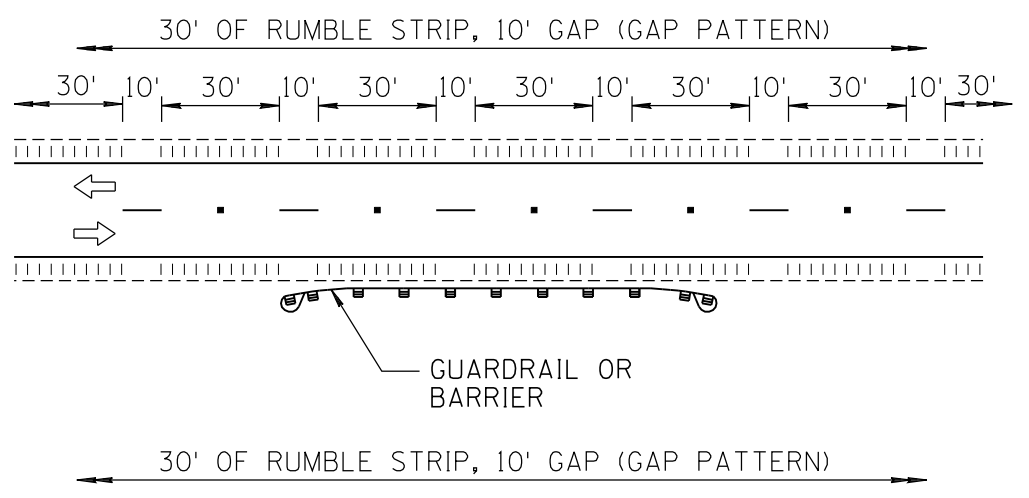

TYPICAL GUARDRAIL AND/OR BARRIER

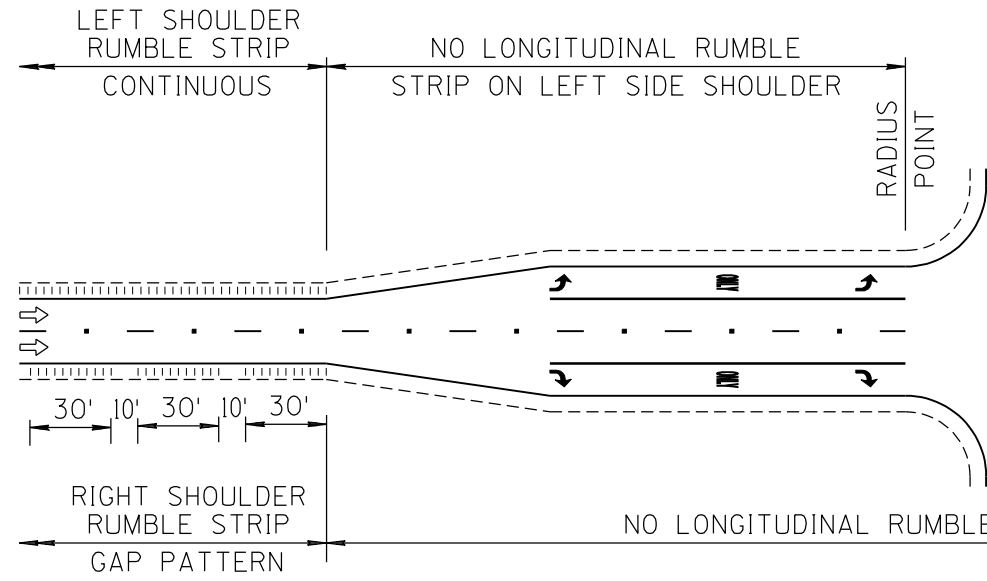

TYPICAL INTERSECTION, TURN LANE & ACCELERATION LANE EXCEPTION DETAIL

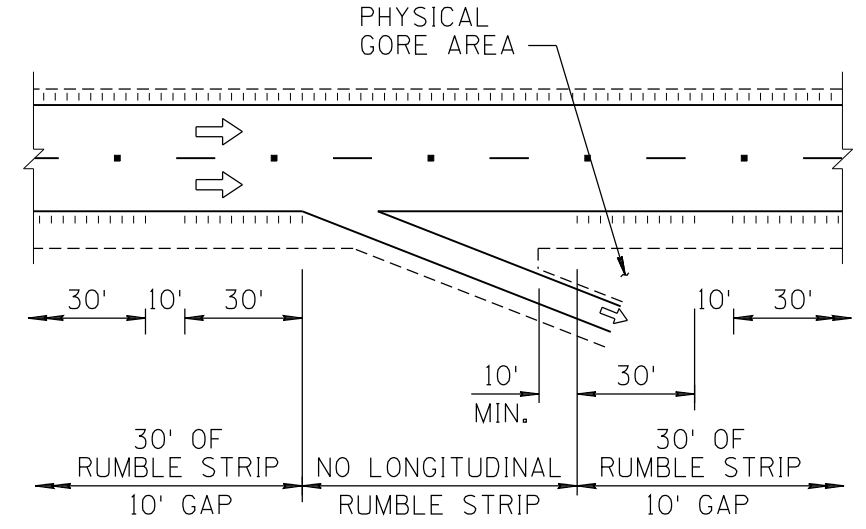
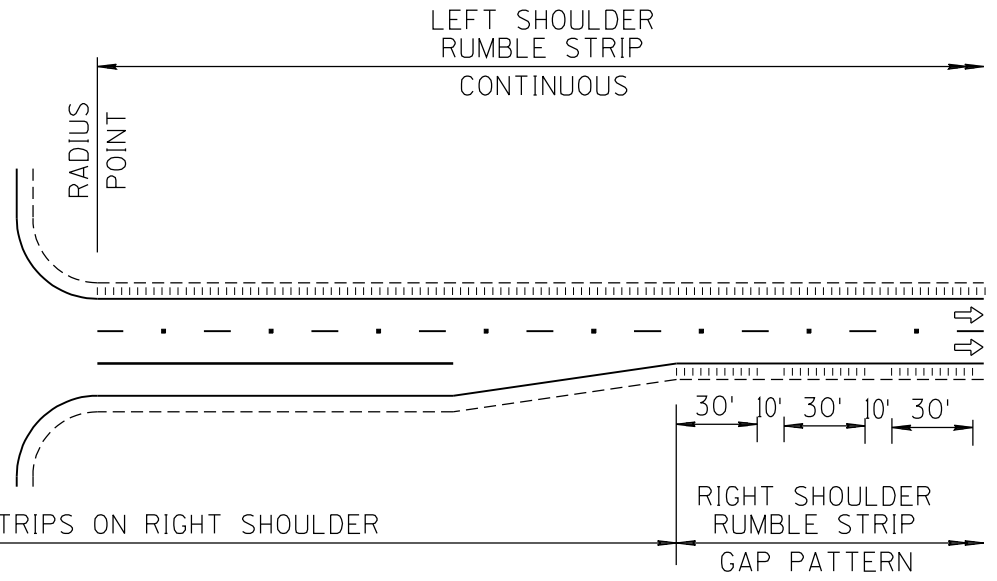

RAMP EXCEPTION DETAIL ENTRANCE RAMP SIMILAR

NOTES:

1. LONGITUDINAL RUMBLE STRIPS SHALL BE OMITTED ACROSS PRINCIPAL INTERSECTING ROADWAYS, OR OTHER INTERRUPTIONS AS SHOWN TYPICALLY HEREIN, ON THE PROJECT PLANS, OR AS DIRECTED BY THE ENGINEER.
2. IF APPRECIABLE BICYCLE TRAFFIC EXISTS OR IS ANTICIPATED, THEN A MINIMUM EFFECTIVE CLEAR SHOULDER WIDTH OF FOUR (4) FEET SHOULD BE PROVIDED.

DESIGN APPROVED	ARIZONA DEPARTMENT OF TRANSPORTATION INTERMODAL TRANSPORTATION DIVISION STANDARD DRAWINGS	REV.
APPROVED FOR DISTRIBUTION		9/08
LONGITUDINAL RUMBLE STRIP EXCEPTION DETAILS		DRAWING NO. M-22