

NO	DESCRIPTION OF REVISIONS	MADE BY	DATE
1	RE-ISSUE	L. LOPEZ	2/02
2			
3			
4			

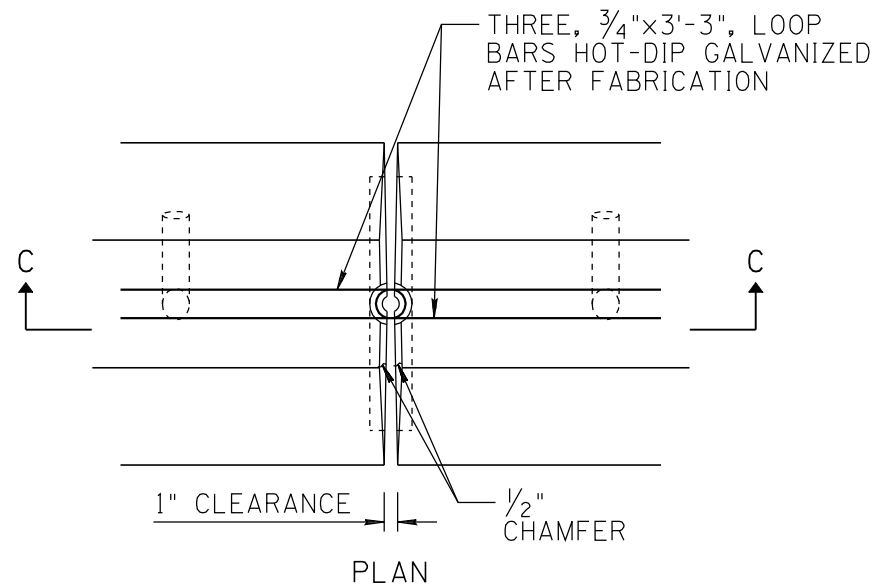

FOR DETAILS NOT SHOWN SEE END VIEWS "A-A" & "B-B" SHEET 1 OF 3

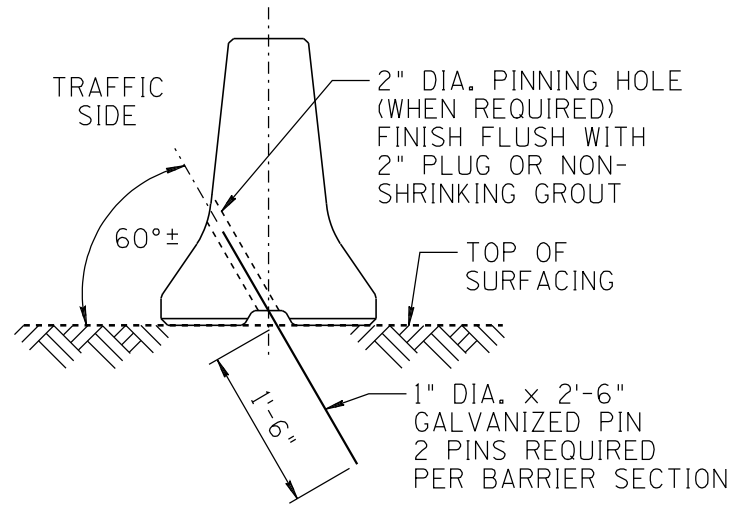

PINNING CONCRETE BARRIER TO ROADWAY DETAIL
(USE WHEN REQUIRED BY PLANS OR AS DIRECTED)

GENERAL NOTES:

1. ALL TEMPORARY CONCRETE BARRIERS INSTALLED ON ADOT PROJECTS AFTER JANUARY 1, 2007; SHALL BE IN ACCORDANCE WITH SHEETS 1 & 2 OF THIS STANDARD DRAWING (NCHRP 350 APPROVED DESIGN).
2. TEMPORARY CONCRETE BARRIER IS TO BE PRECAST CONCRETE MEDIAN BARRIER WITH PIN AND LOOP ASSEMBLY.
3. ALL METAL REINFORCING SHALL BE 2 INCHES CLEAR OF NEAREST FACE OF CONCRETE UNLESS OTHERWISE SHOWN.
4. INSTALL TYPE BM-1 OR BM-2 BARRIER MARKERS AT 25 FT. SPACING. SEE STD. DWG. M-32 & M-33.
5. NORMAL USE OF PRECAST BARRIER UNITS IS RESTRICTED TO CURVATURES WITH RADII GREATER THAN 771 FEET.
6. MAXIMUM CHORD LENGTH FOR CURVES WITH A 1427 FT. RADIUS OR LESS, SHALL BE 12'-6". MAXIMUM CHORD LENGTH FOR CURVES WITH RADII EXCEEDING 1427 FEET, SHALL BE 25 FEET.
7. WHEN SCUPPERS ARE NOT REQUIRED, PLUG THEM WITH 2 INCHES OF GROUT, MINIMUM.
8. CONCRETE GROUTING OF SCUPPERS, SHALL BE NON-SHRINKING, WEAK IN STRENGTH AND OF THICK CONSISTENCY.

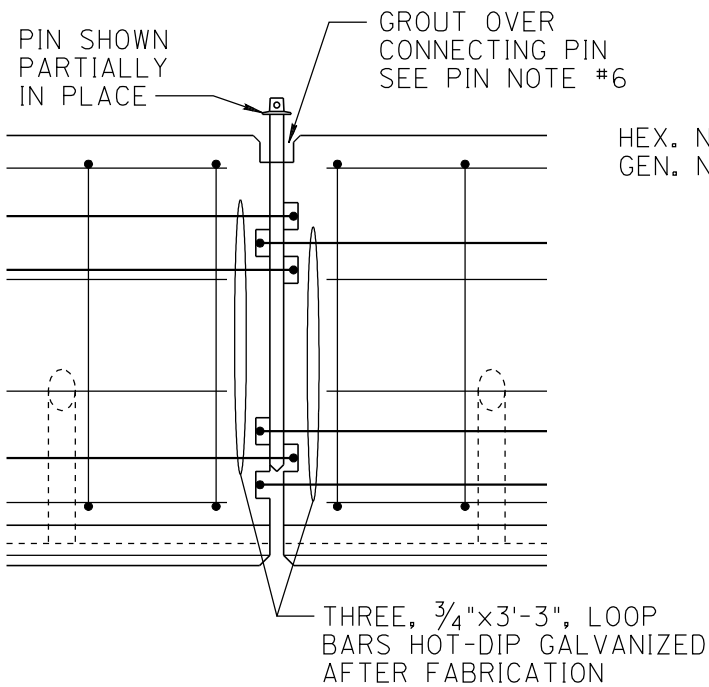

SECTION C-C

FOR DETAILS NOT SHOWN SEE END VIEWS "A-A" & "B-B" SHEET 1 OF 3

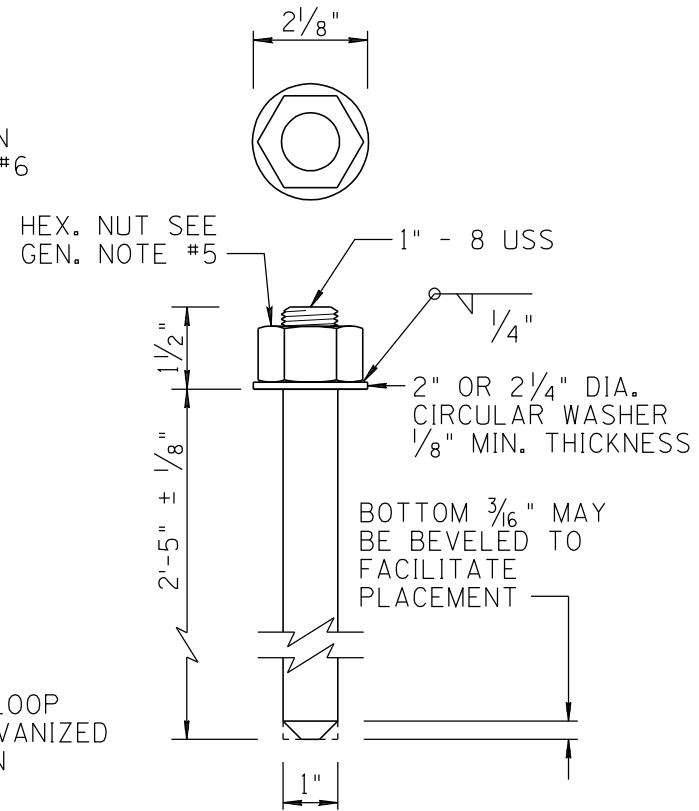

PIN DETAIL

1" PIN GALVANIZE AFTER FABRICATION

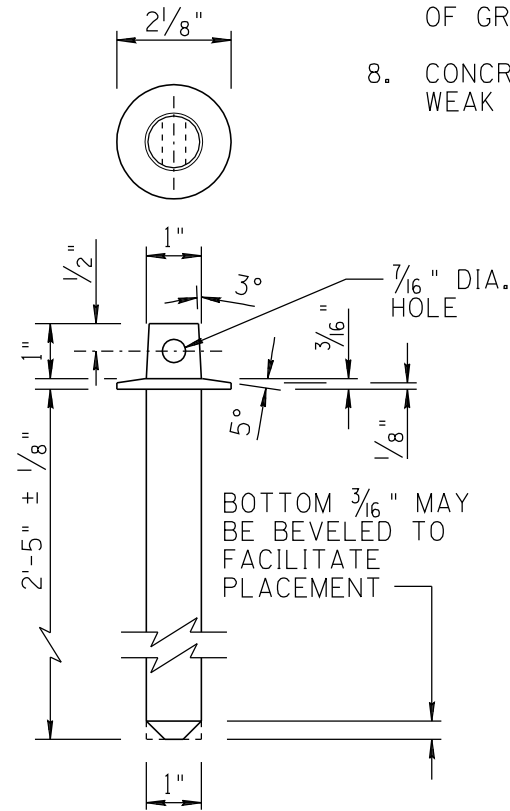

ALTERNATE PIN DETAIL

1" PIN GALVANIZE AFTER FABRICATION

PIN NOTES:

1. WASHER SHALL BE FORGED AS INTEGRAL PART OF THE PIN OR SHALL BE WELDED AS SHOWN.
2. PIN SHALL BE GALVANIZED AFTER FABRICATION ACCORDING TO ASTM A153.
3. PINS THAT CONFORM TO CRITICAL DIMENSIONS, (PIN LENGTH & DIA., WASHER DIA. & THICKNESS), ARE ACCEPTABLE IF AN APPROVED TOP CONFIGURATION FOR LIFTING THE PIN IS PROVIDED.
4. PINS SHALL CONFORM TO ASTM A449.
5. TO FACILITATE PIN REMOVAL, THREAD HEX. NUT HALFWAY ONTO THE PIN AND TACK WELD OR PROVIDE A COUPLING NUT, TIGHTENED SUFFICIENTLY TO PREVENT LOOSENING. FILL NUT WITH GREASE TO EXCLUDE ICE OR OTHER CONTAMINATES.
6. CONCRETE GROUTING OVER PINS AND PINNING HOLES, SHALL BE NON-SHRINKING, WEAK IN STRENGTH AND OF THICK CONSISTENCY.

SHEET 2 OF 3
NOT TO SCALE

DESIGN APPROVED APPROVED FOR DISTRIBUTION	ARIZONA DEPARTMENT OF TRANSPORTATION INTERMODAL TRANSPORTATION DIVISION STANDARD DRAWINGS	REV. 2/02
	PRECAST CONCRETE BARRIER PIN AND LOOP ASSEMBLY NCHRP 350 APPROVED DESIGN	DRAWING NO. C-3