

DATE	
MADE BY	
DESCRIPTION OF REVISIONS	
NO	3
DATE	09/11
MADE BY	C. COLE
DESCRIPTION OF REVISIONS	
NO	2
DESCRIPTION OF REVISIONS	NEW STANDARD
NO	1
DESCRIPTION OF REVISIONS	2011 EDITION - NEW STANDARD

NOTES:

1. See Specifications for materials and construction for retrofit installations.
2. See T.S. 1-4 for most installation requirements, the steel lid shall be bonded.
3. See T.S. 1-5 for conduit requirements.
4. Box and lid per this drawing are for off-roadway non-deliberate traffic areas. These boxes shall not be used in sidewalks or other paved areas.
5. The lid thickness tolerance $1\frac{3}{4}$ " is also based on how the lid fits onto the pull box body. The fit shall be such that the lid does not project above or lie below the surface of the pull box body lip. Lids and box body have an allowable tolerance of $\frac{1}{8}$ ".
6. Pull box shall be precast using Class "S" (3000 PSI) concrete,
7. Conduit ends shall have a nominal 6" to 8" clearance from the bottom of the lid to allow for connectors and slack wire. Extensions or deeper boxes shall be used as necessary to maintain this clearance and to provide needed volume for cables, conductors, and connections.
8. All pull box lids shall be non-skid galvanized steel and all exposed metal shall be galvanized.
9. Apply zinc rich anti-seize compound to all threaded fasteners prior to final insertion.
10. This box shall typically be used for roadway lighting application in urbanized areas.

ADOT DESIGNATION	NOMINAL SIZE DESIGNATION	LID		FRAME		BOX		FOOTING		LOAD RATING
		A	B	C	E	F	G	H	J	
No. 4 HD Pull Box	12" X 24"	12"	23 $\frac{1}{4}$ "	12 $\frac{3}{4}$ "	24"	19"	30 $\frac{1}{4}$ "	35"	46 $\frac{1}{4}$ "	HD+
No. 6 HD Pull Box	16" X 30"	16"	30"	16 $\frac{3}{4}$ "	30 $\frac{3}{4}$ "	23"	37"	39"	53"	HD+

(+ Exceeds the ANSI/SCTE 77 Tier 22 Requirements)

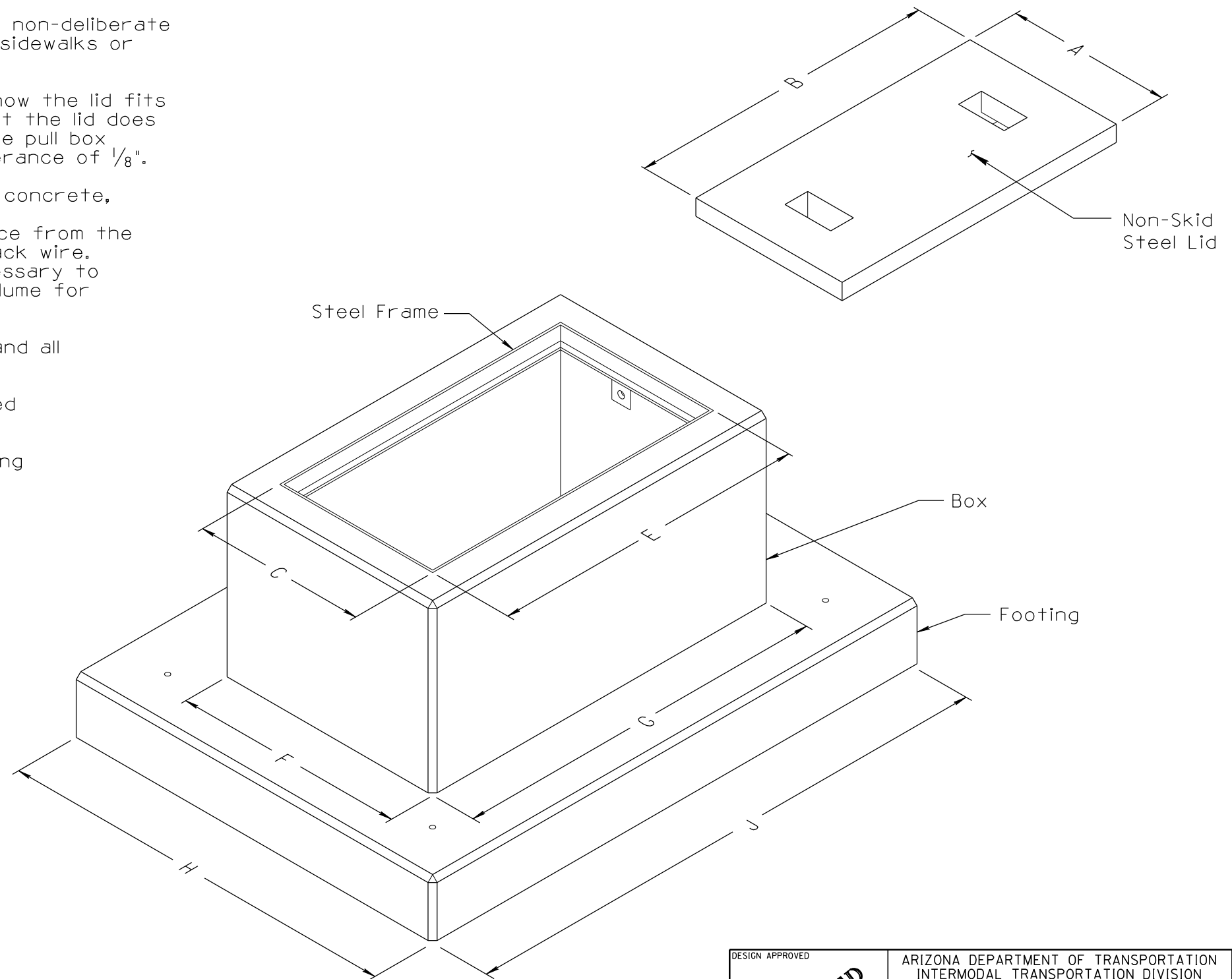

NOT TO SCALE

DESIGN APPROVED	ARIZONA DEPARTMENT OF TRANSPORTATION INTERMODAL TRANSPORTATION DIVISION TRAFFIC SIGNALS AND LIGHTING STANDARD DRAWINGS	REVISION	09/11
APPROVED FOR DISTRIBUTION		DRAWING NO.	T.S. 1-11
	HEAVY DUTY LIGHTING NO. 4 AND NO. 6 PULL BOX	SHEET NO.	1 OF 4