

NOTES:

1. Rise angle per manufacturer's plans.
2. Dimensions A, B, and D are determined by the manufacturer based on the design criteria provided on T-SL 4.11
3. Weld symbols not shown. All weld symbols shall be shown on the shop drawings.

TABLE 1			
SIGNAL MAST ARM INFORMATION			
Pole Name	45-RL	50-RL	55-RL
Nominal Mast Arm Length	45'-0"	50'-0"	55'-0"
Minimum Mast Arm Base Plate Size	18"x18"	18"x18"	18"x18"

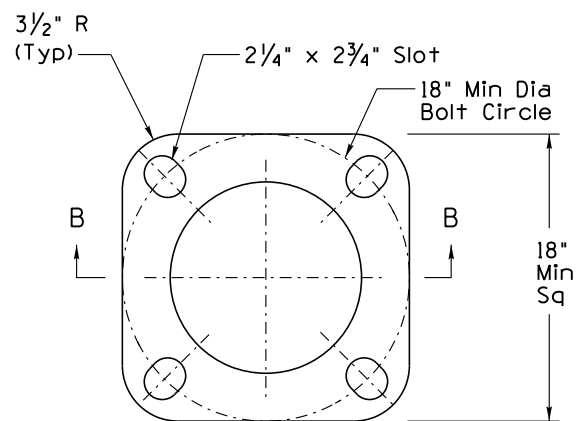

BASE PLATE DETAIL

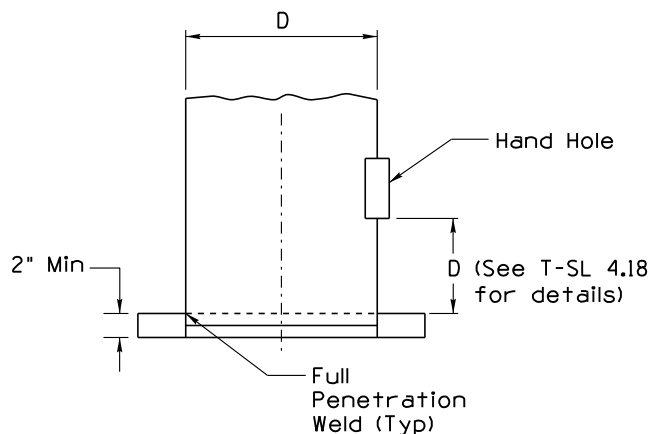
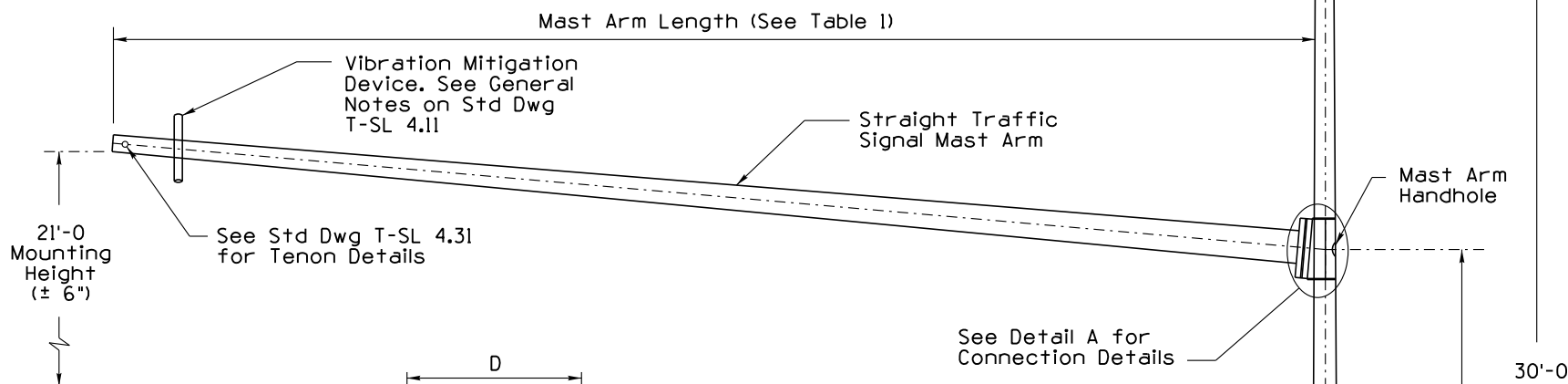

SECTION B-B
(Bolt Slots Not Shown)

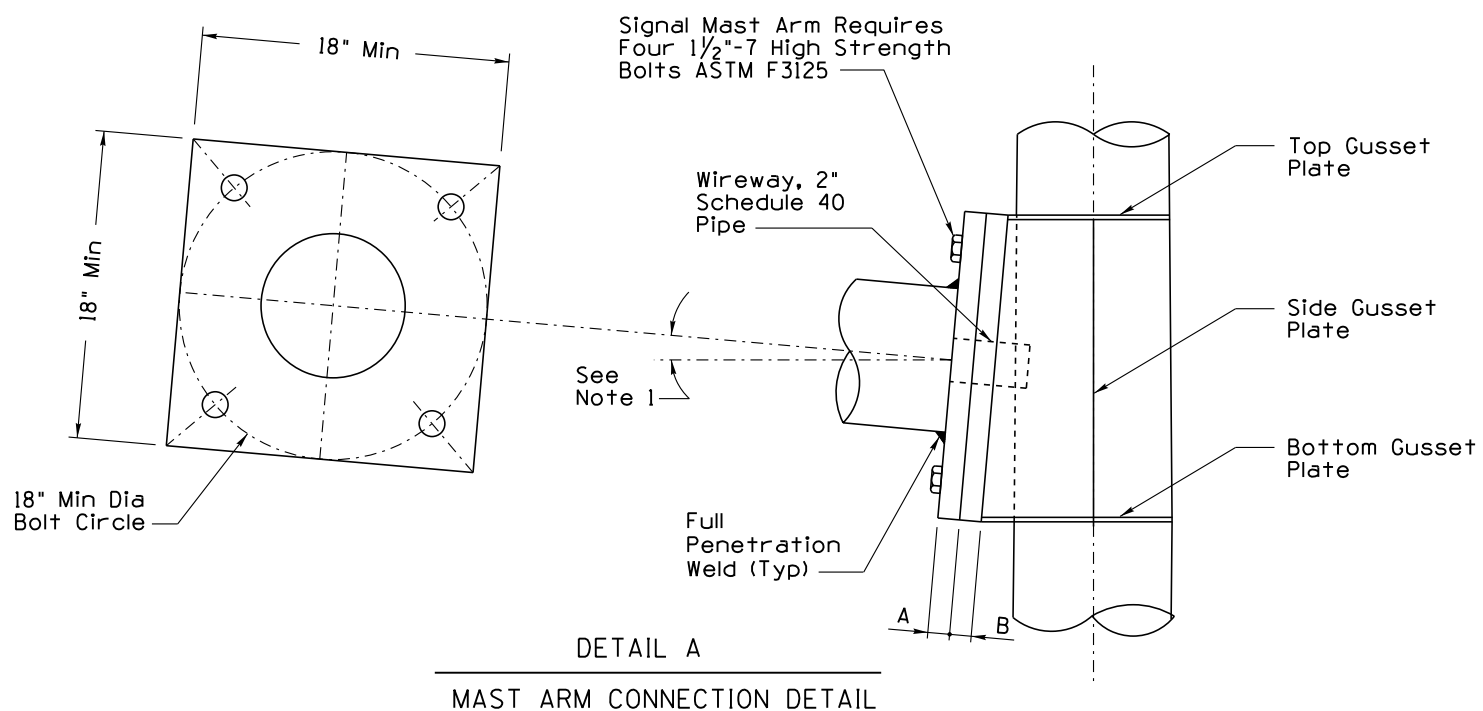

DETAIL A
MAST ARM CONNECTION DETAIL

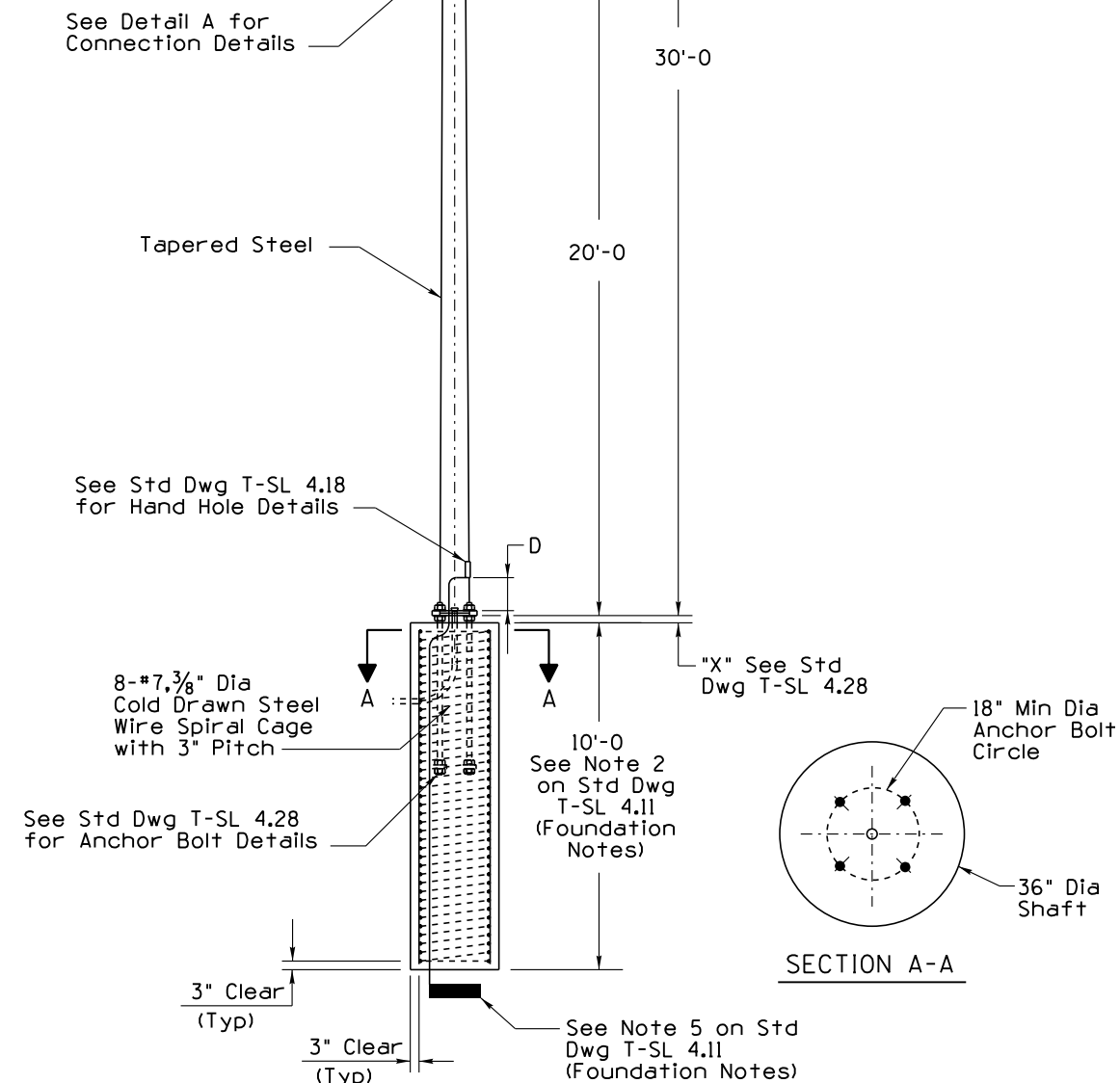

SECTION A-A

STANDARDS ENGINEER A. ALZUBI	ARIZONA DEPARTMENT OF TRANSPORTATION INFRASTRUCTURE DELIVERY AND OPERATIONS DIVISION TRAFFIC SIGNAL & LIGHTING STANDARD DRAWING	
RECOMMENDED FOR APPROVAL GROUP MANAGER M. HANNA	TYPE R POLES (45-RL, 50-RL, AND 55-RL) WITH 45 FT TO 55 FT MAST ARM SPAN LENGTH WITH LUMINAIRE	DRAWING NO. T-SL 4.15
APPROVED STANDARDS COMMITTEE APPROVED FOR DISTRIBUTION	DATE 04/19	

Note to Designer: The information presented in this Standard Drawing has been prepared in accordance with recognized engineering principles and is for general use. It should not be used for specific application without competent professional examination and verification of its suitability and applicability by a licensed professional engineer. Comments within the inner border line shall not be altered.

PRIOR DISTRIBUTION DATE