

Note to Designer: The information presented in this Standard Drawing has been prepared in accordance with recognized engineering principles and is for general use. It should not be used for specific application without competent professional examination and verification of its suitability and applicability by a licensed professional engineer. Contents within the inner border line shall not be altered.

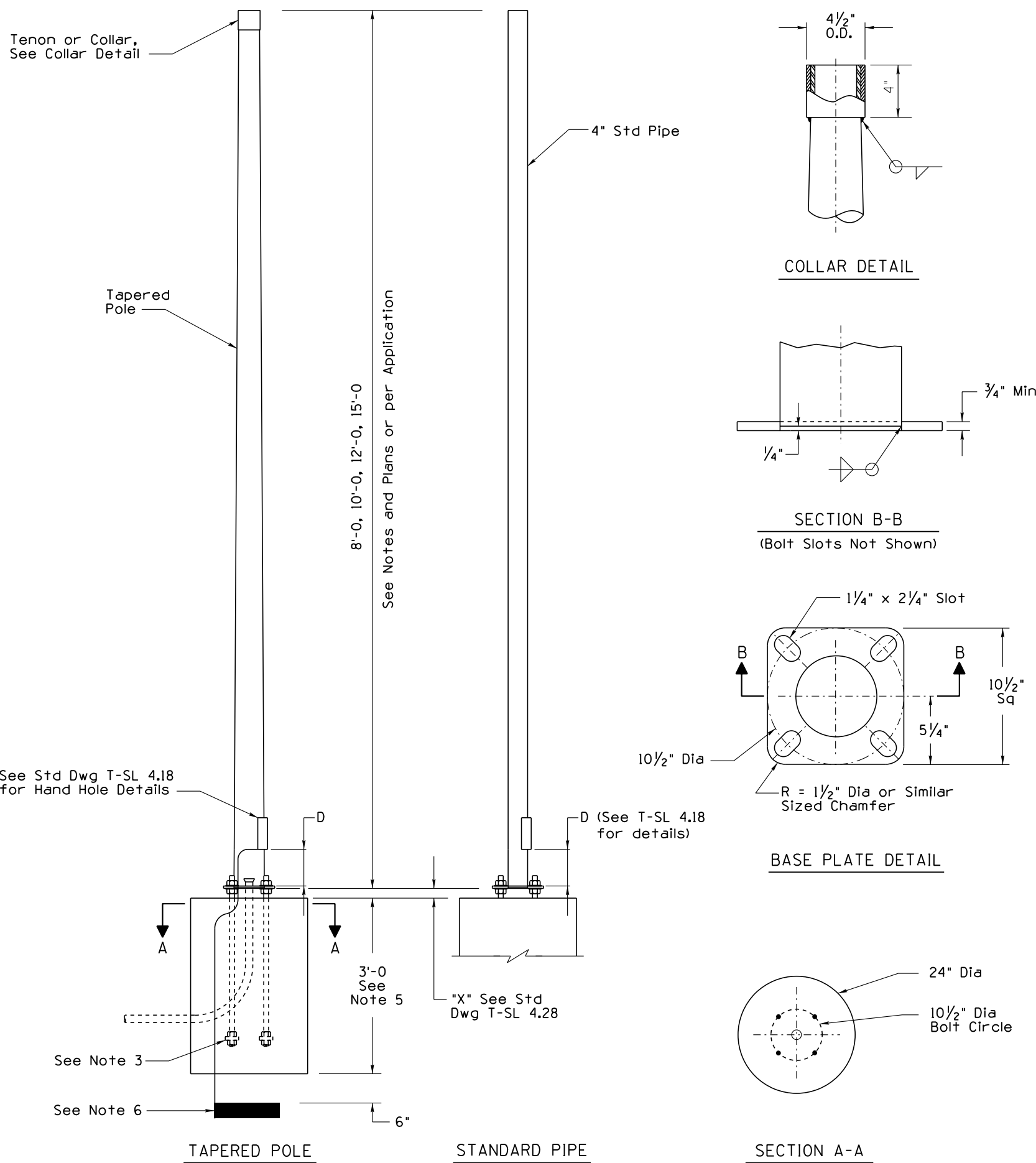

**NOTES:**

1. All materials and construction shall conform to the requirements of the Arizona Department of Transportation Standard Specifications for Road and Bridge Construction.
2. Poles shall comply with the requirements of the AASHTO Standard Specifications for Structural Supports for Highway Signs, Luminaires, and Traffic Signals, 6th Edition (2013), with 2015 Interim Revisions.
3. See Std Dwg T-SL 4.28 for anchor bolt details.
4. The foundation hole shall be augered and Class "S" (3,500 psi) concrete, poured against undisturbed compacted earth.
5. Unstable soil and/or a steep slope may require a deeper foundation. See Arizona Department of Transportation Standard Specifications.
6. A 25 ft coil of #4 AWG bare copper conductor or a 14 inch square copper ground plate shall be installed before the concrete is poured and connected to pole grounding lug in the hand hole. The ground plate or coil shall be covered with 6 inches of fill.
7. Pole may have a continuous taper unless the pipe is a straight pole.
8. Once the pole installation is completed, the open space between the base plate and foundation shall be grouted.
9. If pole foundation is within or adjacent to sidewalk, top of pole foundation shall be flush with the abutting or adjacent sidewalk.
10. Tapered pole diameter at the base and the top is dependent on the taper rate used by the manufacturer.
11. Shop drawings shall be submitted to the Engineer for review prior to fabrication in accordance with the Standard Specifications.
12. All dimensions not shown on the plans are dependent on the manufacturer's design, and shall be shown on the shop drawings.
13. Signed and sealed shop drawings shall be submitted to the Engineer for review and approval prior to fabrication in accordance with the Standard Specifications, unless the manufacturer has been granted approval on the Department's most recently published Approved Product List (APL).
14. All dimensions are nominal.

STANDARDS ENGINEER <b>A. ALZUBI</b>	ARIZONA DEPARTMENT OF TRANSPORTATION INFRASTRUCTURE DELIVERY AND OPERATIONS DIVISION TRAFFIC SIGNAL & LIGHTING STANDARD DRAWING	
RECOMMENDED FOR APPROVAL GROUP MANAGER <b>M. HANNA</b>	TYPE A POLE	DRAWING NO. T-SL 4.01
APPROVED STANDARDS COMMITTEE APPROVED FOR DISTRIBUTION		DATE 04/19