

NO.	DATE	MADE BY	DESCRIPTION OF REVISIONS
3	03/10	C. COLE	
4			
NO.	DATE	MADE BY	DESCRIPTION OF REVISIONS
1			
2			

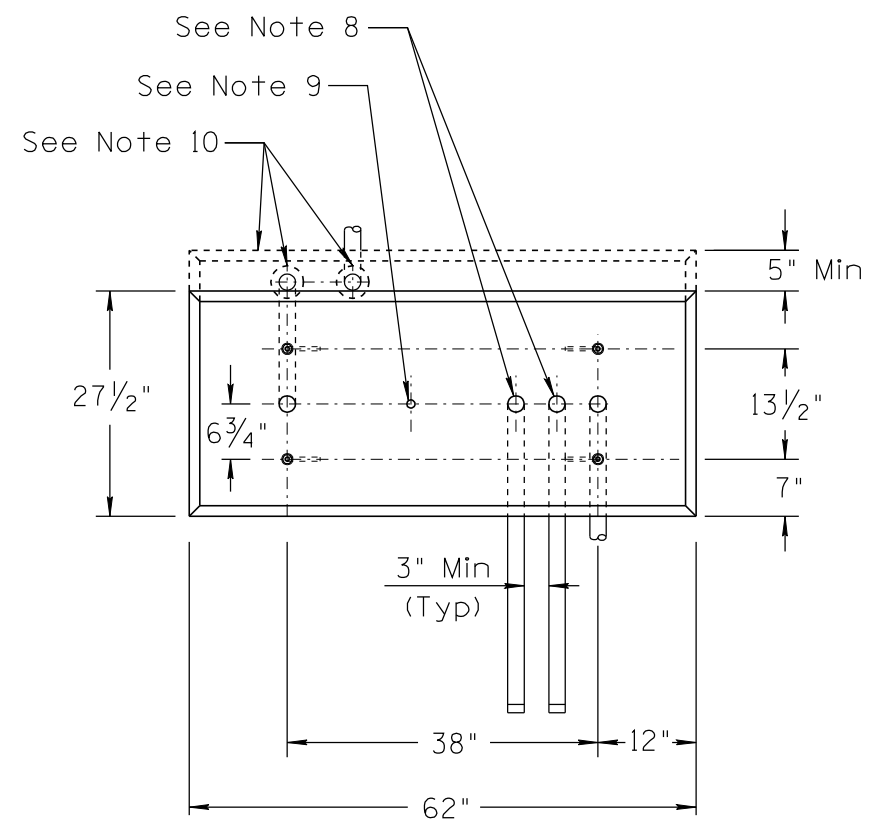

FOUNDATION PLAN
(See Project Plans for Conduit Size)

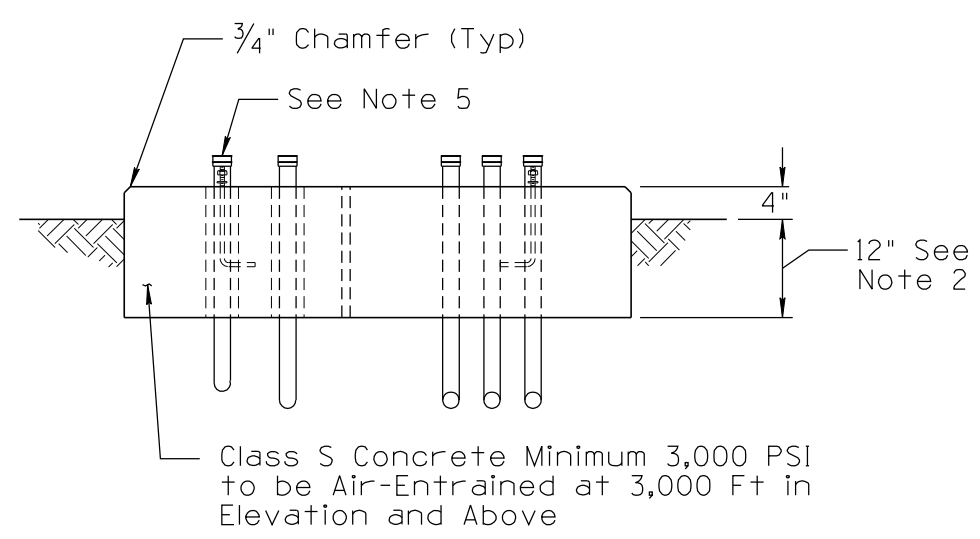

FRONT VIEW

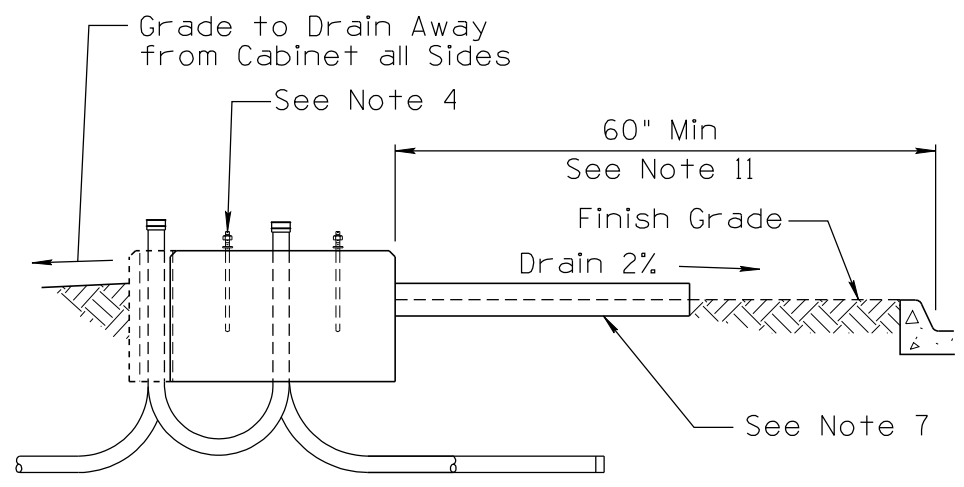

LEFT SIDE VIEW

NOTES:

1. All materials and construction shall conform to the requirements of the Specifications.
2. Unstable soil and/or steep slopes may require deeper foundations. See Specifications. Load centers shall not be located in drainage areas unless they are elevated.
3. For conduit size, location, and quantity, see plans. Typical minimum size is 2".
4. Anchor bolts shall be galvanized 1/2" x 12" x 4" or 5" complete with nuts and washers. Anchor bolt projection above foundation shall be 1 1/2" Min to 2 1/2" Max.
5. Conduit projection above foundation shall be 2" Min to 4" Max. Conduits shall be capped.
6. Use an approved Silicon Sealer RTV Type, Grey in color or Clear, between cabinet and foundation.
7. In unpaved areas, a raised PCC pad 36" x 4" x 37" shall be placed at the in front of the cabinet. Pad shall be set 2" below the foundation elevation and sloped away from cabinet for drainage (2% Min.).
8. Install one 2" conduit for future use, stubbed and capped 24" past the edge of the foundation, as directed by the Engineer.
9. 1" sleeve for ground rod.
10. Back side of foundation shall be increased by at least 5" when EUSERC Meter Socket or utility pull section and/or service disconnect enclosure are required. The 4" sleeves are for Service conduits. The contractor shall confirm serving utility's requirements and power drop location prior to construction.
11. Additional offset should be provided if available, or if clear zone requirements dictate. On high speed roadways, offset shall be 30' or more.

NOT TO SCALE

DESIGN APPROVED	ARIZONA DEPARTMENT OF TRANSPORTATION INTERMODAL TRANSPORTATION DIVISION TRAFFIC SIGNALS AND LIGHTING STANDARD DRAWINGS	REVISION 03/10
SIGNATURE		DRAWING NO. T.S. 2-2
APPROVED FOR DISTRIBUTION	FOUNDATION FOR TYPE IV LOAD CENTER CABINET	SHEET NO. 1 OF 1
ON FILE		