

NO	DESCRIPTION OF REVISIONS	MADE BY	DATE
1	REISSUED STANDARD DRAWING	RLF	5/07
2			
3			
4			

Concrete Half Barrier
42" Type 'F' With Gutter
Std Dwg C-10.53 or
as Shown on Plans

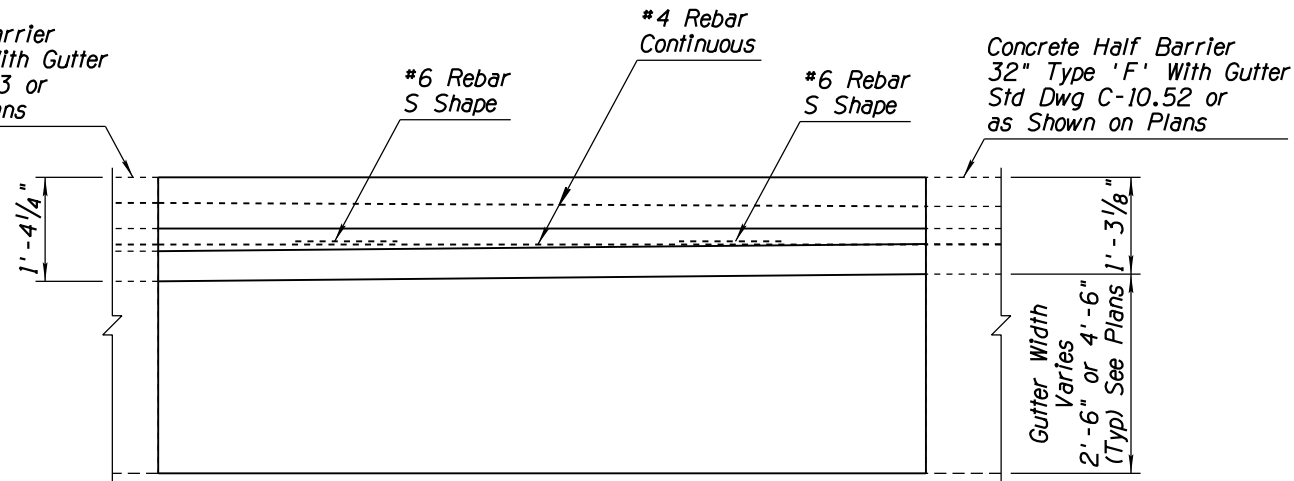

PLAN

Construction Joint
See Note 5

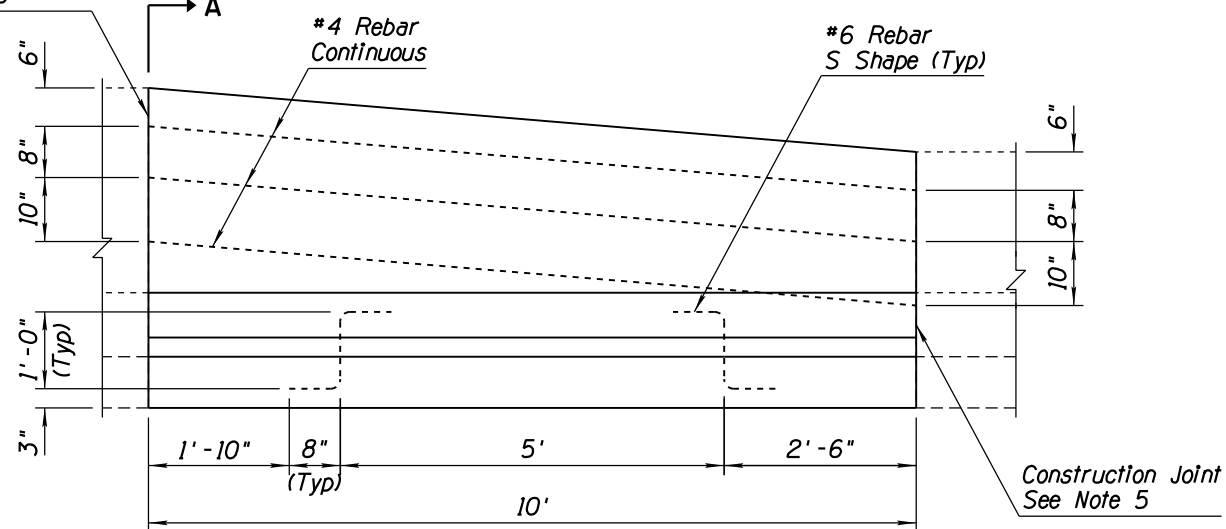

ELEVATION

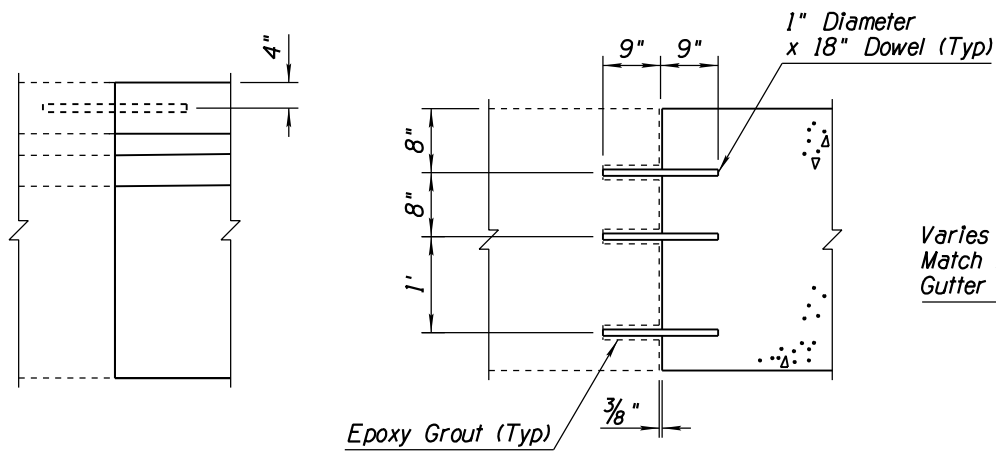

PLAN

ELEVATION

CONSTRUCTION JOINT DETAIL
(OPTIONAL)

Varies
Match Adjoining
Gutter Depression

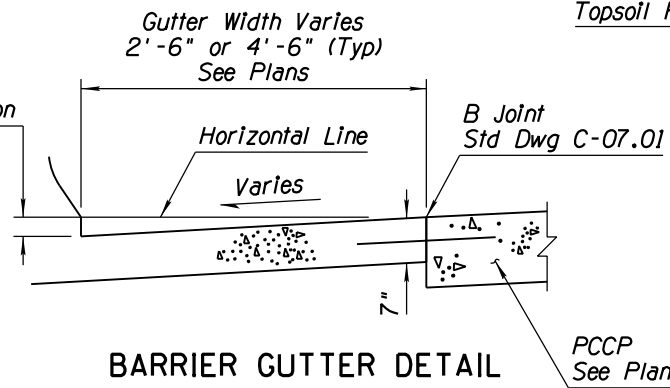

BARRIER GUTTER DETAIL

Topsoil Plating

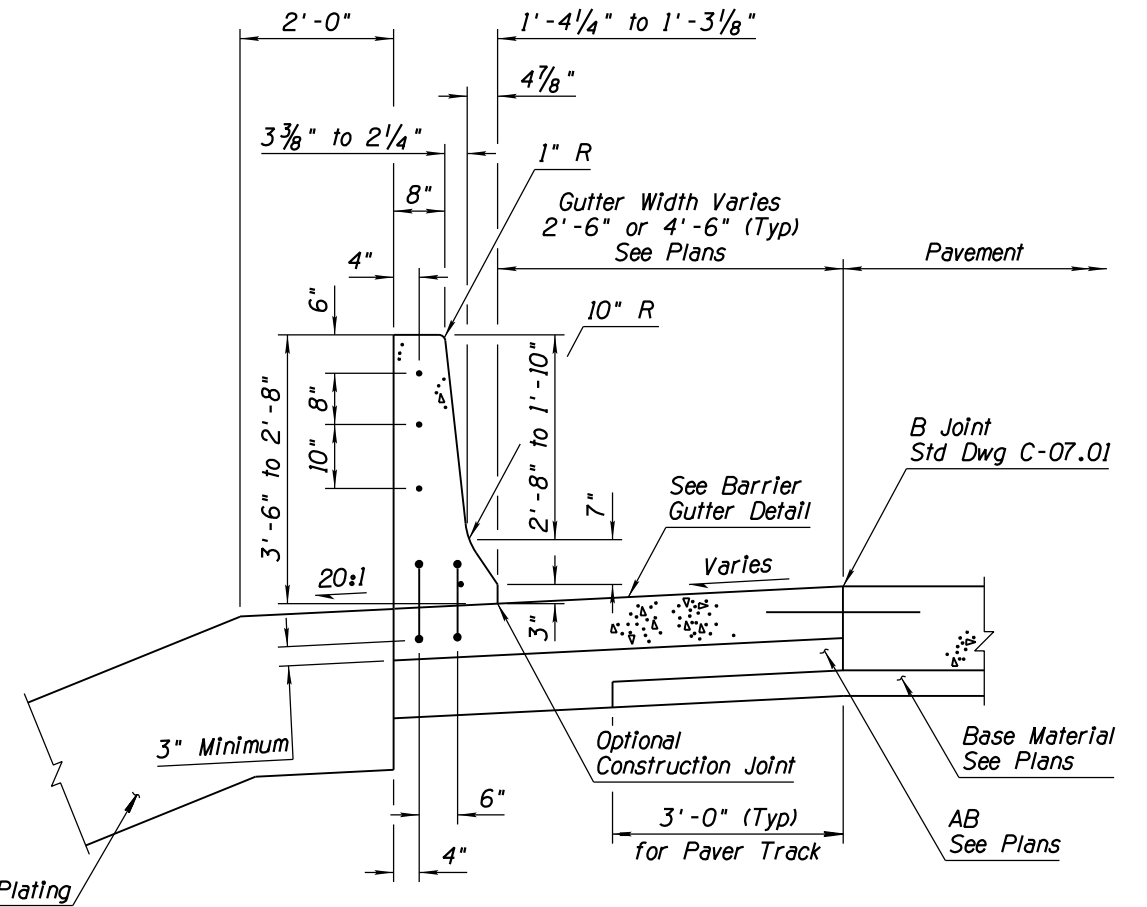

SECTION A-A

APPROVED FOR DESIGN 	STATE OF ARIZONA DEPARTMENT OF TRANSPORTATION ROADWAY STANDARD DRAWINGS	REV. 5/12
APPROVED FOR DISTRIBUTION 	CONCRETE HALF-BARRIER TRANSITION 42" TO 32" TYPE 'F'	DRAWING NO. C-10.74