

NO.	DESCRIPTION OF REVISIONS	MADE BY	DATE
1	RENAMED STD DWG FROM C-10.45 & REVISED TITLE	RLF	9/04
2	REVISED DESIGNATION	RLF	9/04
3	REVISED GENERAL NOTE 2	RLF	9/04
4			

### GENERAL NOTES

- The cable assembly shall be tightened to remove slack.
  - One wrap of 14 gauge galvanized steel wire shall be wrapped around the terminal post near the top of the bearing plate.
  - See Std Dwg C-10.00 for measurement limits.
- - Indicates AASHTO, AGC & ARTBA Task Force 13 Report designation

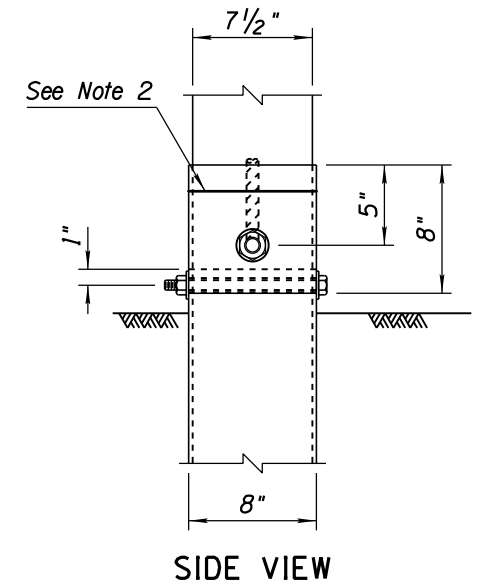
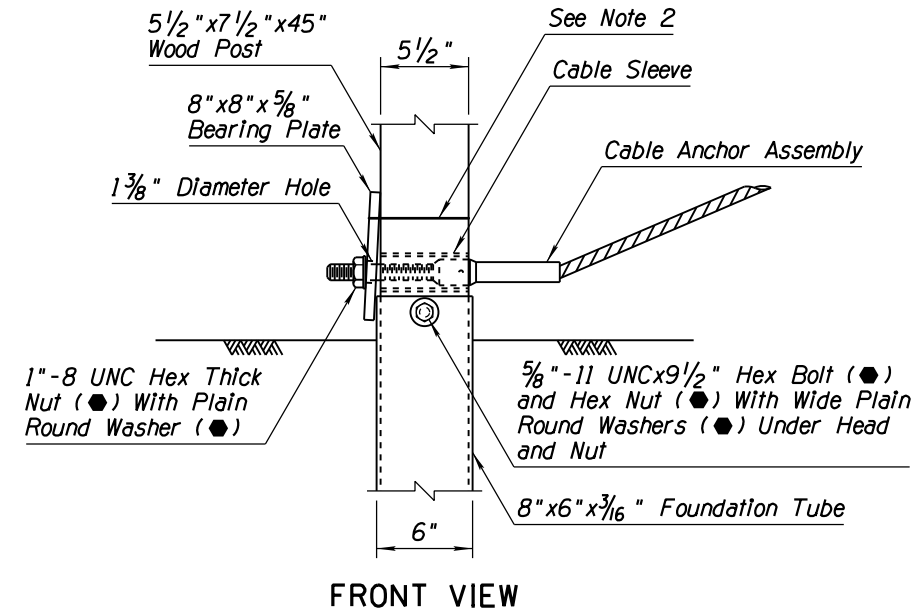
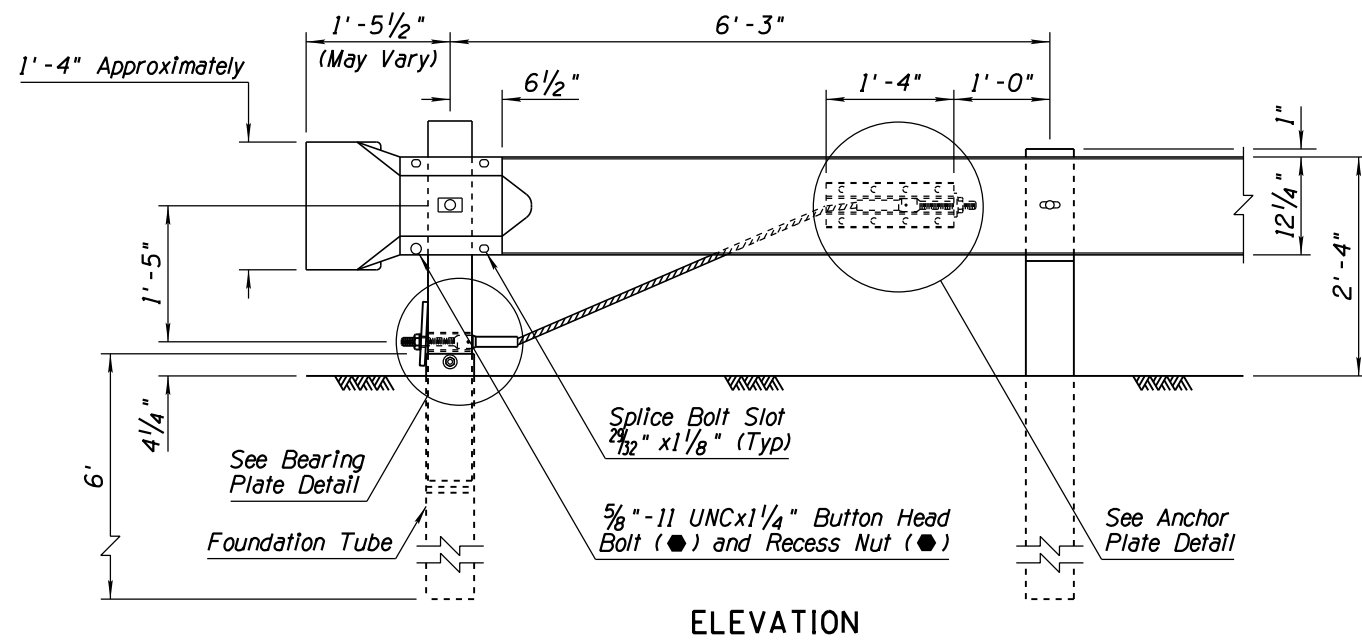
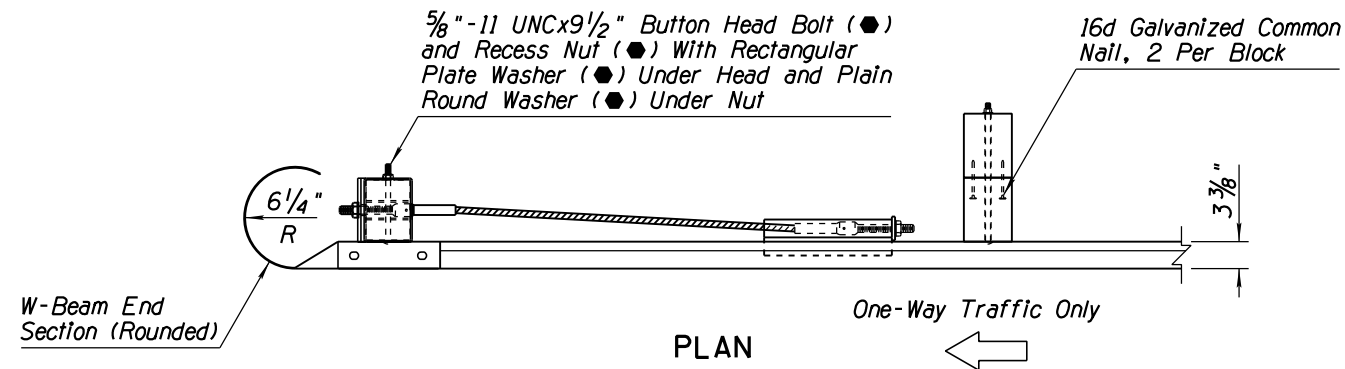

### BEARING PLATE DETAIL

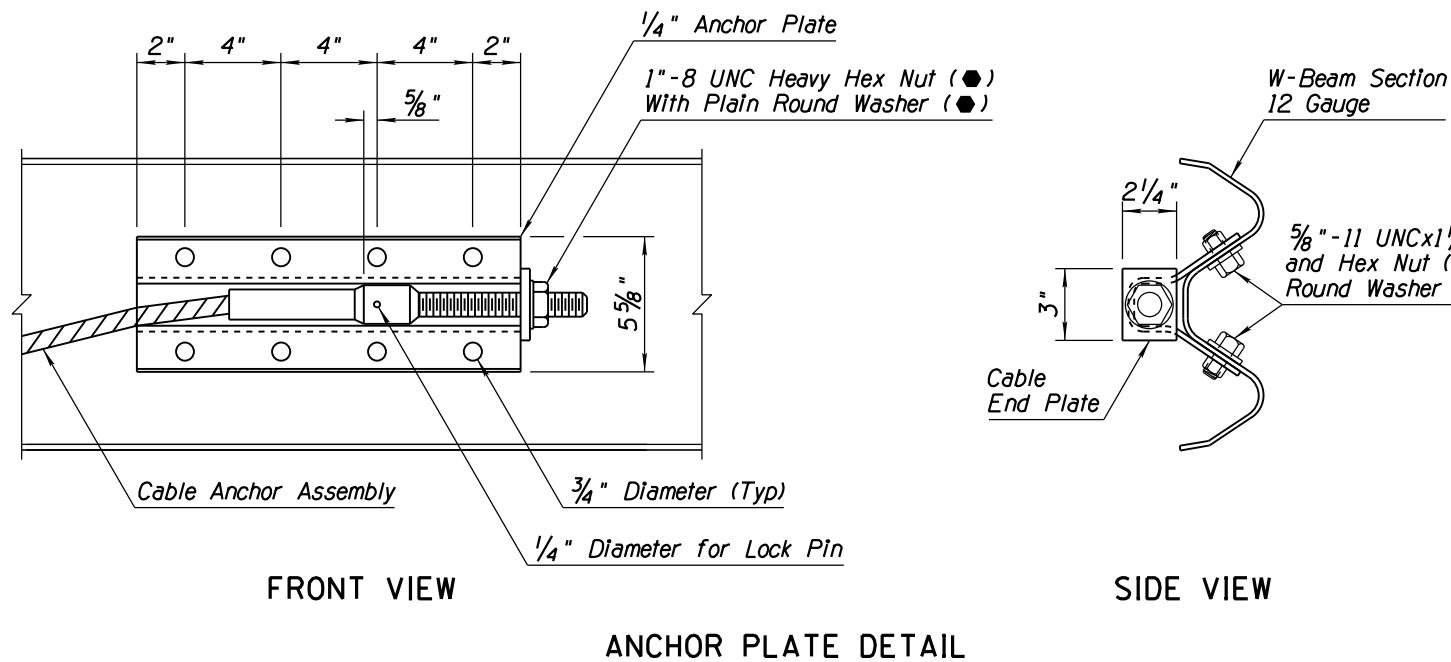

APPROVED FOR DESIGN 	STATE OF ARIZONA DEPARTMENT OF TRANSPORTATION ROADWAY STANDARD DRAWINGS	REV. 5/12
APPROVED FOR DISTRIBUTION 	W-BEAM GUARDRAIL END ANCHOR	DRAWING NO. C-10.08