

NO	DESCRIPTION OF REVISIONS	MADE BY	DATE
1	REISSUED STANDARD DRAWING	RLF	7/05
2	CORRECTED GENERAL NOTE REFERENCE	RLF	5/07
3	MODIFIED PLAN AND SECTION VIEWS	RLF	5/07
4			

### GENERAL NOTES

1. Location may be adjusted to accommodate guardrail post layout.
  2. All concrete shall be Class B. Embankment curb concrete shall be in accordance with the Std Specs.
  3. Where rock is encountered the outlet may be omitted, as approved by the Engineer.
  4. When outlet is used, the wire mesh shall extend through the joint into the outlet in lieu of bending into the key.
  5. Spillway invert slope shall be uniformly downward from A to B. See Section B-B.
  6. See Std Dwg C-04.30 for spillway length.
  7. See Std Dwg C-10.06 for nested guardrail requirements.
- 72" Timber Post

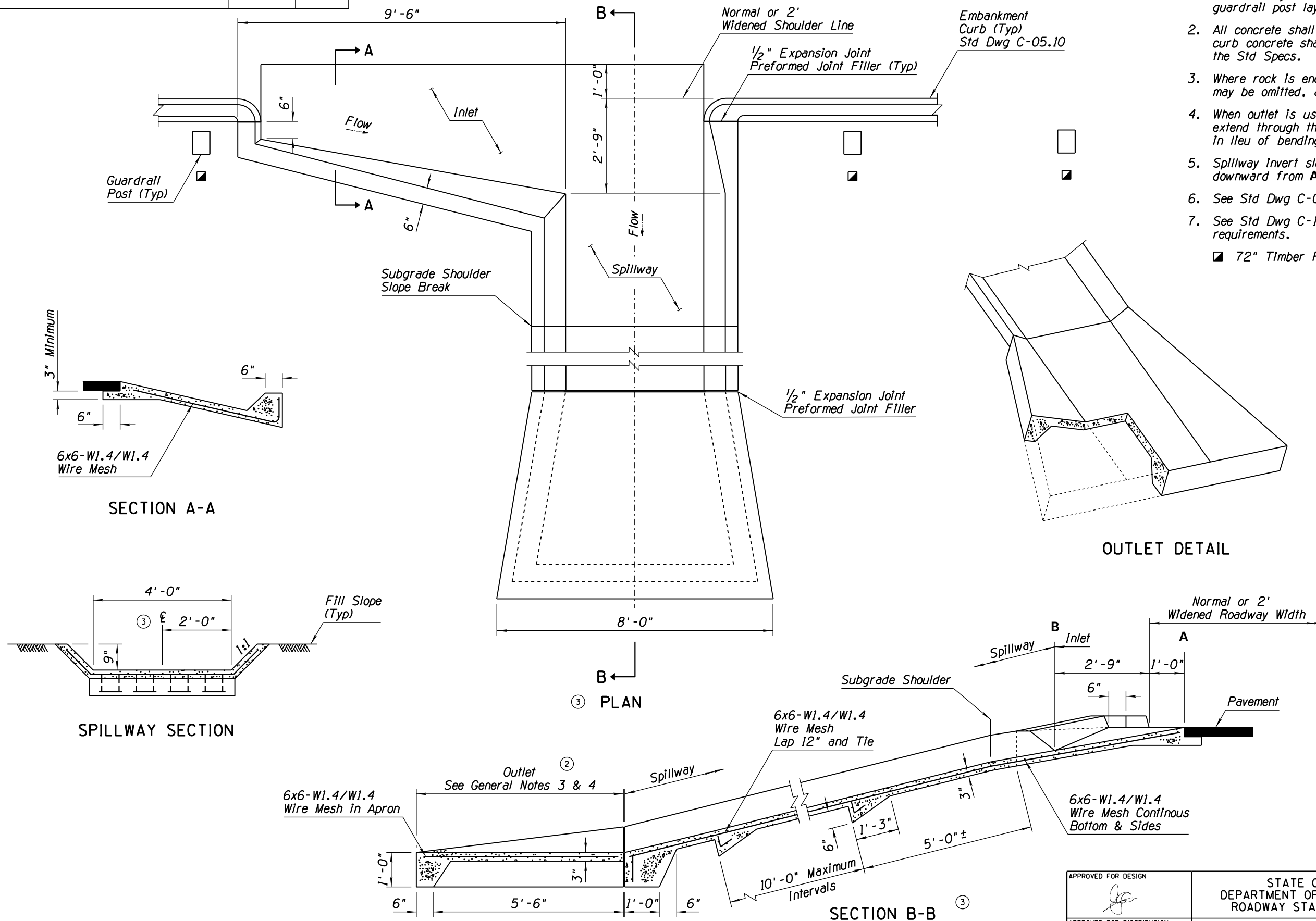

APPROVED FOR DESIGN <i>[Signature]</i>	STATE OF ARIZONA DEPARTMENT OF TRANSPORTATION ROADWAY STANDARD DRAWINGS	REV. 5/12
APPROVED FOR DISTRIBUTION <i>[Signature]</i>	SPILLWAY, EMBANKMENT SINGLE INLET	DRAWING NO. ① C-04.10 Sheet 1 of 2