

NO.	DESCRIPTION OF REVISIONS	MADE BY	DATE
1	NEW GENERAL NOTE 1	RLF	9/04
2			
3			
4			

### GENERAL NOTES

- ① 1. End section joint type shall match the pipe joint type.
2. Embankment slope shall be warped to match slope of end section.

Pipe Diameter (In)	Approximate Weight (Lbs)	Dimensions (In)						Approximate Slope
		T	A	B	C	E	F	
24	1520	3	9 1/2	43 1/2	30	73 1/2	48	3
27	1930	3 1/4	10 1/2	49 1/2	24	73 1/2	54	3
30	2190	3 1/2	12	54	19 3/4	73 3/4	60	3
36	4100	4	15	63	34 3/4	97 3/4	72	3
42	5380	4 1/2	21	63	35	98	78	3

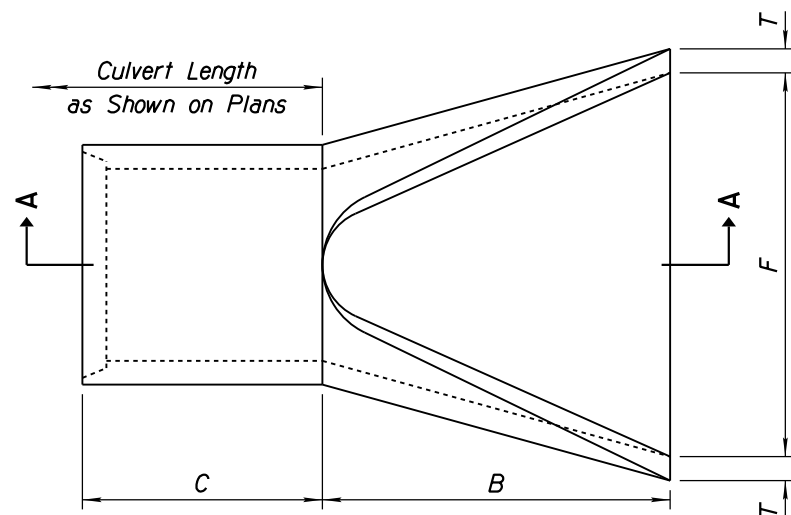

PLAN

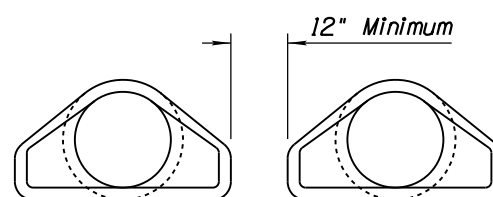

SPACING FOR MULTIPLE INSTALLATION

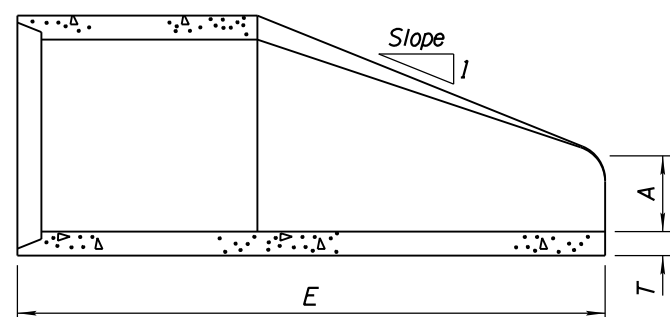

SECTION A-A

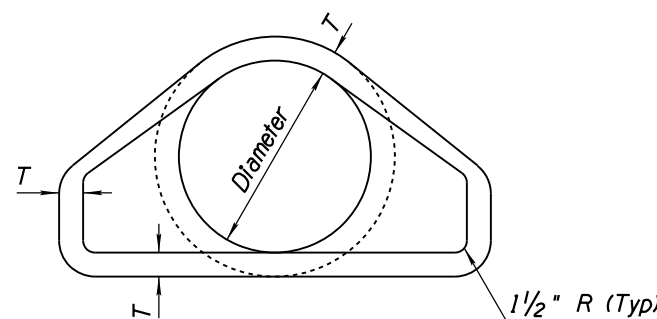

FRONT ELEVATION

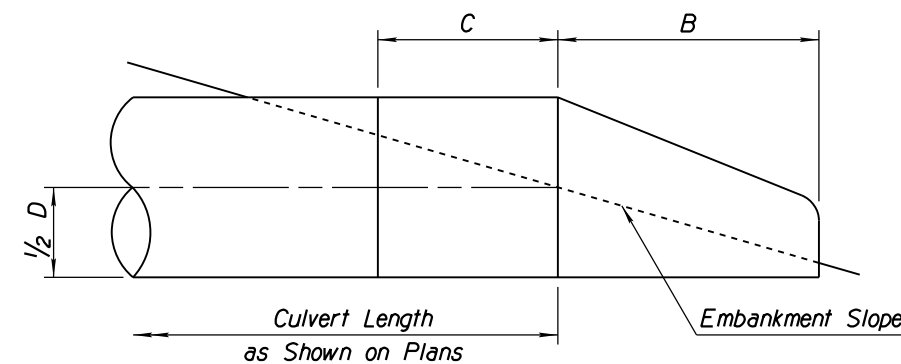

RIGHT-ANGLE CULVERT

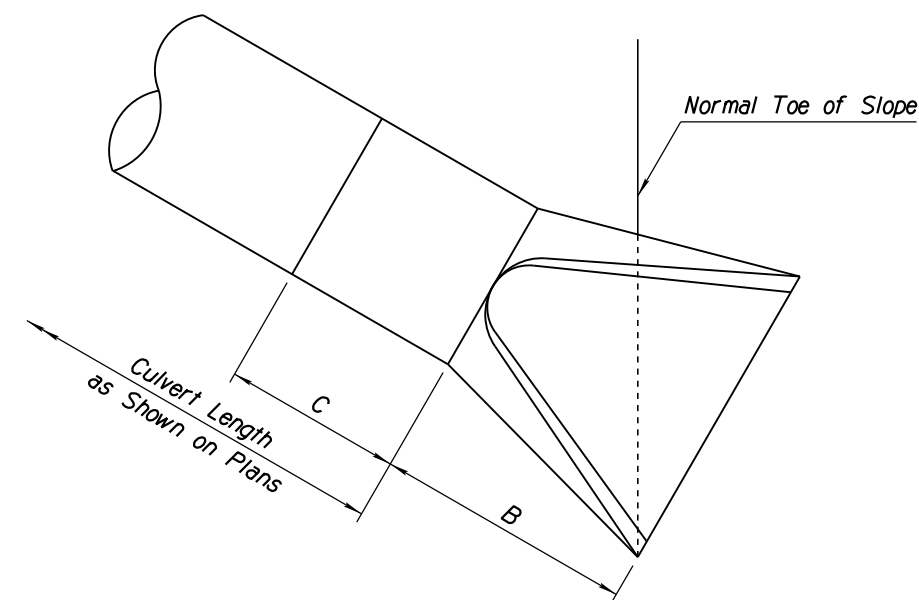

SKEWED CULVERT

APPROVED FOR DESIGN 	STATE OF ARIZONA DEPARTMENT OF TRANSPORTATION ROADWAY STANDARD DRAWINGS	REV. 5/12
APPROVED FOR DISTRIBUTION 	PIPE REINFORCED CONCRETE END SECTION	DRAWING NO. C-13.20