

Note to Designer: This Standard Drawing has been prepared in accordance with recognized engineering principles and is for general use. It should not be used for specific application without competent professional examination and verification of its suitability and applicability by a licensed professional engineer. Contents within the inner border line shall not be altered.

PRIOR DISTRIBUTION DATE 05/12

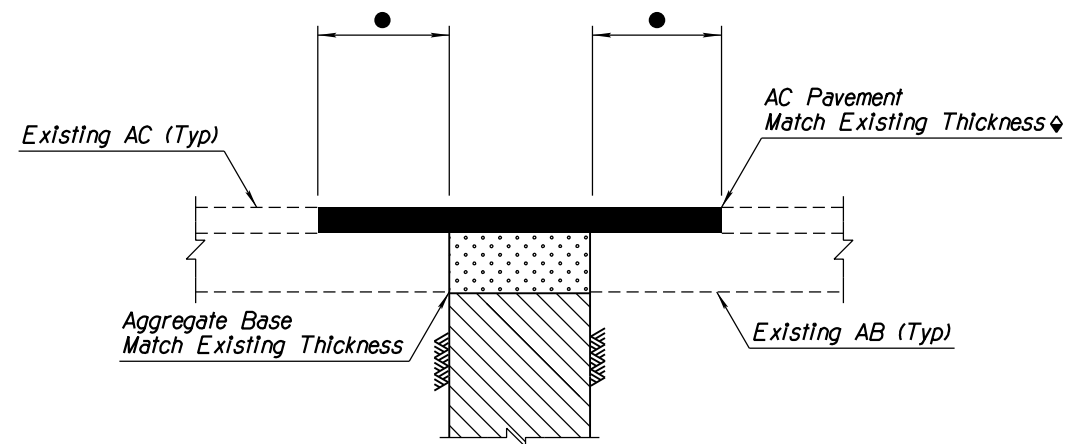

AC PAVEMENT

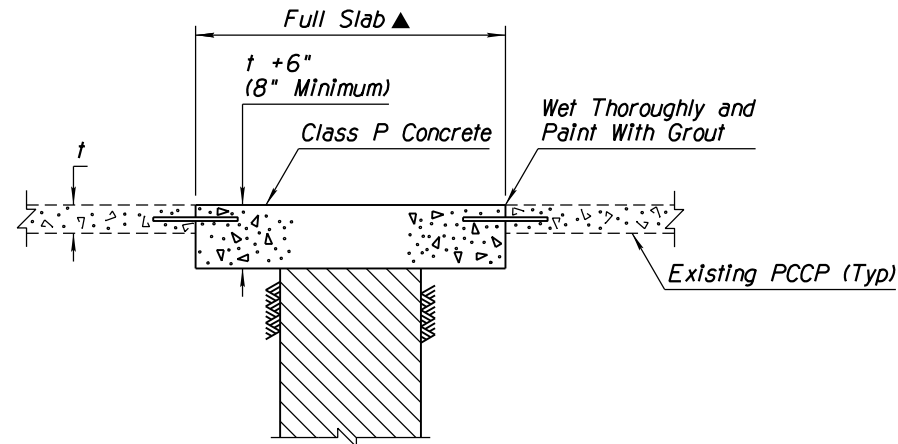

PCCP PAVEMENT

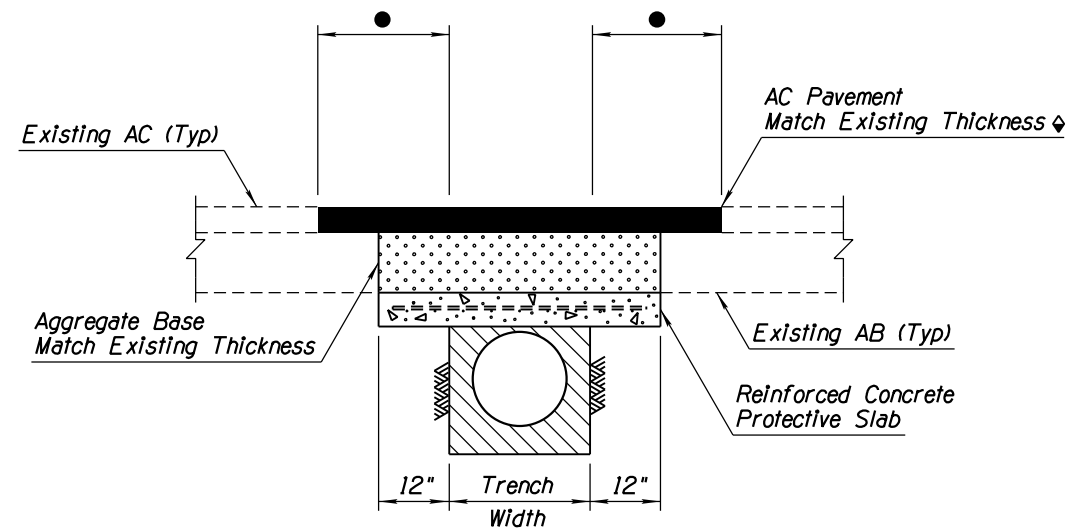

SHALLOW COVER ■

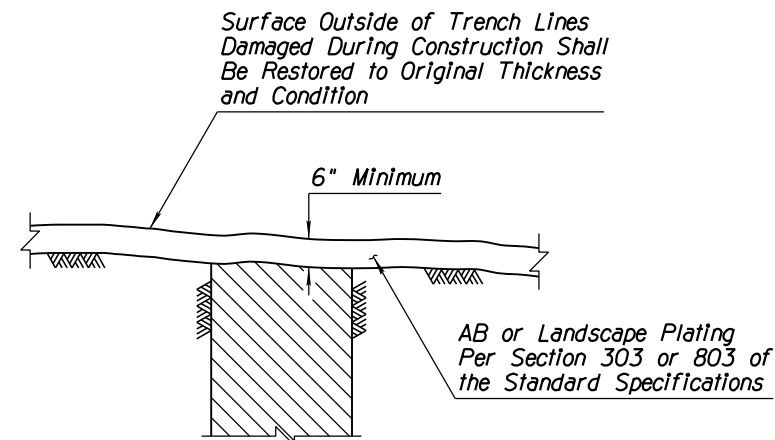

PLATED SURFACE

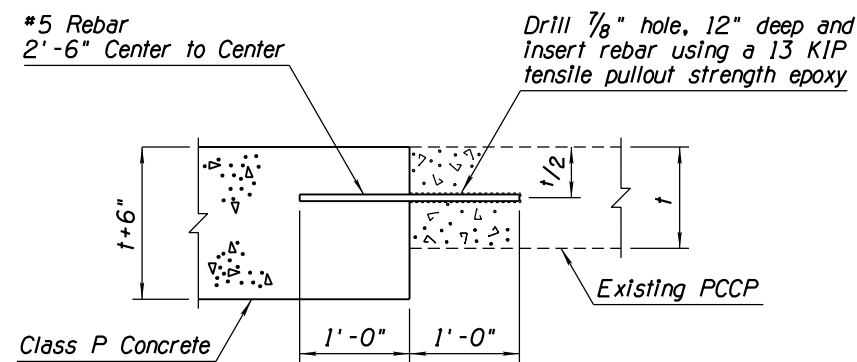

DOWEL DETAIL

GENERAL NOTES

1. Backfill shall be in accordance with Section 501 bedding and pipe backfill requirements of the Standard Specifications.
2. Aggregate Base shall be in accordance with Section 303 requirements of the Standard Specifications.
3. Asphalt concrete shall be in accordance with Section 409 requirements of the Standard Specifications.
4. Portland Cement Concrete Pavement shall be in accordance with Section 401 requirements of the Standard Specifications. Match existing surface texture and grade.
5. See Std Dwg C-13.15 for pipe culvert installation.

● Replace 2 ft of AC on each side of the excavation along centerline unless otherwise directed by the Engineer. Replace full lane width of all disturbed lanes perpendicular to centerline.

▲ All disturbed slabs shall be replaced in full and doweled into adjacent PCCP on each side. See Dowel Detail.

■ Use when shown on plans or as directed by the Engineer when minimum cover cannot be attained. See plans for protective slab thickness and reinforcement requirements.

◇ A thicker pavement section may be required if shown on plans or directed by the Engineer.



BACKFILL

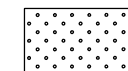

AGGREGATE BASE

STANDARDS ENGINEER <b>J. C. COOPER</b>	ARIZONA DEPARTMENT OF TRANSPORTATION INFRASTRUCTURE DELIVERY AND OPERATIONS DIVISION ROADWAY GROUP STANDARD DRAWING	
RECOMMENDED FOR APPROVAL GROUP MANAGER <b>M. DENBLEYKER</b>	TRENCH BACKFILL AND PAVEMENT REPLACEMENT	DRAWING NO. C-07.06
APPROVED STANDARDS COMMITTEE APPROVED FOR DISTRIBUTION		08/21 DATE