

DESIGNATOR	BASE METAL THICKNESS
RWE03a	2.67

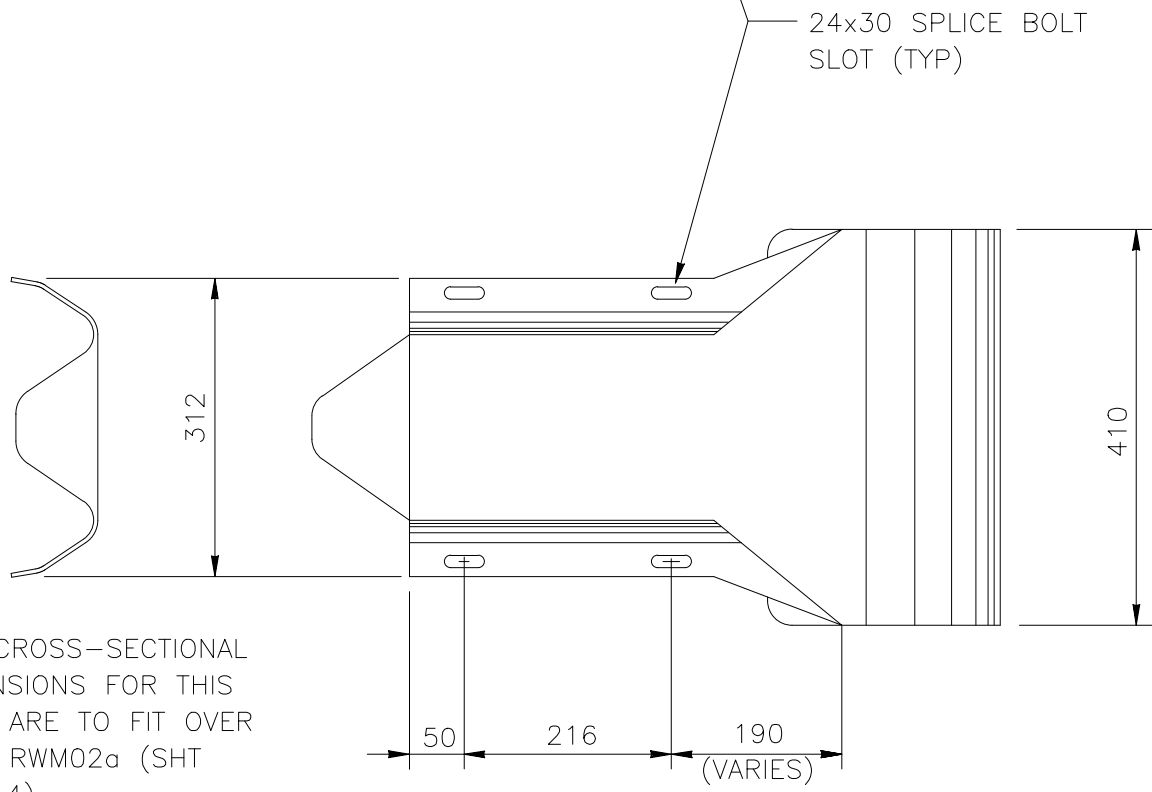
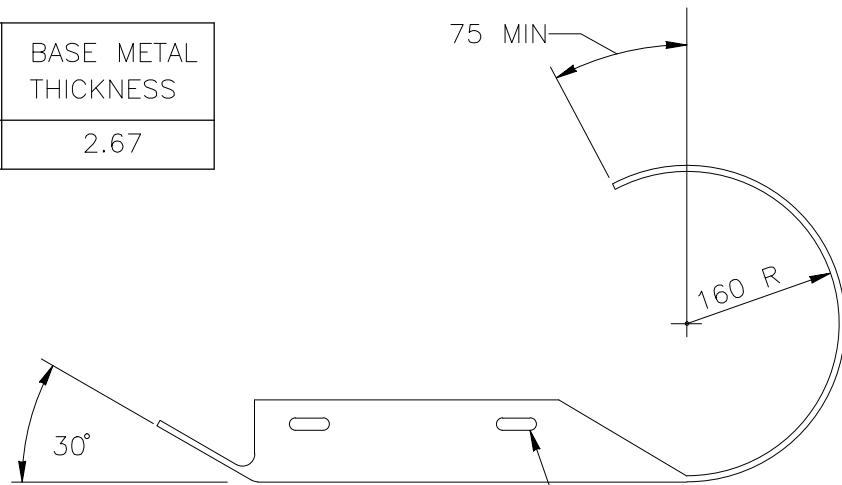

THE CROSS-SECTIONAL DIMENSIONS FOR THIS PART ARE TO FIT OVER PART RWM02a (SHT 3 of 4).

1994

W-BEAM END SECTION (ROUNDED)

RWE03a

SHEET NO.

REF. NO.

1 of 2

RE-6-79

SPECIFICATIONS

Rounded W-beam end sections shall conform to the current requirements of AASHTO M180. End section RWE03a shall conform to AASHTO M180 Class A and RWE03b shall conform to Class B. Corrosion protection may be either Type II (zinc-coated) or Type IV (corrosion resistant steel). Corrosion resistant steel should conform to ASTM A606 for Type IV material and shall not be zinc-coated, painted or otherwise treated.

Dimensional tolerances not shown or implied are intended to be those consistent with the proper functioning of the part, including its appearance and accepted manufacturing practices.

INTENDED USE

This rounded W-beam end section is used in some terminal configurations employed with the SGR04a-b W-beam guardrails and SGM04a-b median barriers.

W-BEAM END SECTION (ROUNDED)

RWE03a

SHEET NO.

DATE

2 of 2

04-01-95

