

WELD END PLATE TO BRACKET

6 140 THREE SIDES

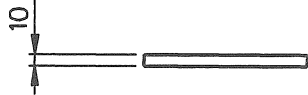

END PLATE

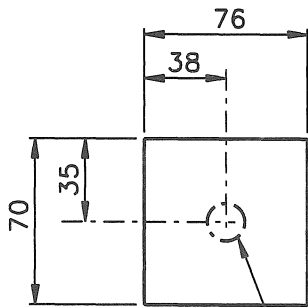
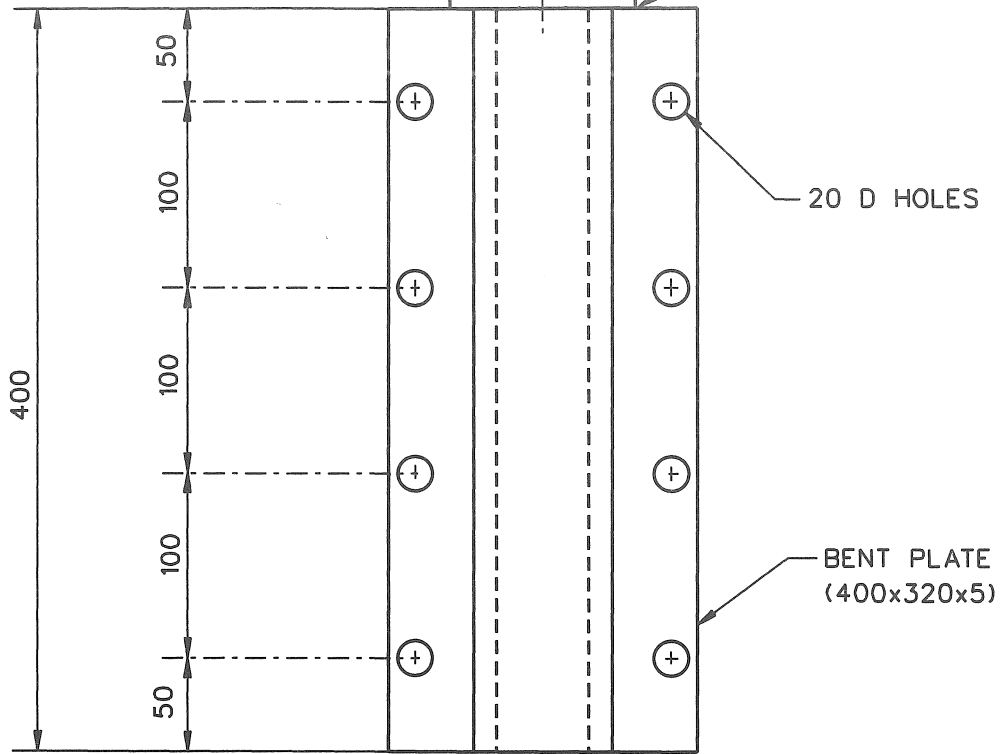
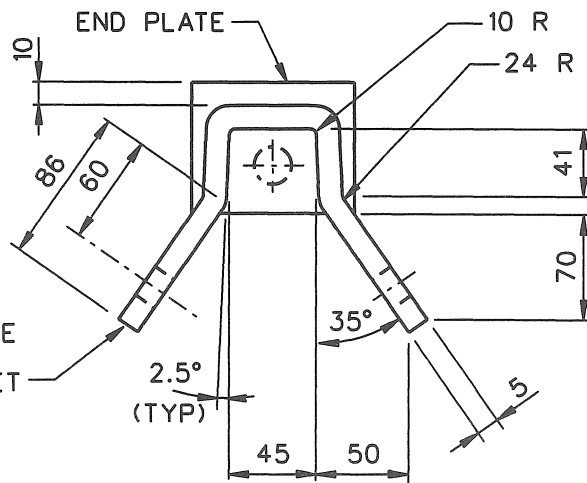

BRACKET

1994

GUARDRAIL ANCHOR BRACKET



FPA01

DATE:

REF. NO.

1 of 2

RE-71-79

SPECIFICATIONS

The cable anchor bracket and end plate shall be manufactured from AASHTO M270M (ASTM A709M) Grade 250 steel plate and zinc-coated according to AASHTO M111 (ASTM A123) except when corrosion resistant steel is requested. No punching, drilling or cutting is permitted after the bracket is zinc-coated. When corrosion resistant steel is desired, the bracket shall be manufactured from ASTM A606 Type IV material and shall not be painted or zinc-coated.

Dimensional tolerances not shown or implied are intended to be those consistent with the proper functioning of the part, including its appearance and accepted manufacturing practices.

INTENDED USE

This bracket can be attached to W-beam (RWM14a) using 8 40-mm FBX16a bolts and nuts. The anchor cable (FCA01) fits through the inside of the bracket and attaches to the end plate. This bracket is used in the breakaway cable terminal (SEW03a-b and SEW04a-b) and the modified eccentric loader terminal (SEW05) and the trailing end terminals (SEW02a and SEW02b).

GUARDRAIL ANCHOR BRACKET

FPA01

SHEET NO.

DATE

2 of 2

04-01-95

