

MARICOPA COUNTY TRANSPORTATION EXCISE TAX

FY 2019 ACTUAL REVENUE DISTRIBUTION FLOW

(Millions of Dollars)

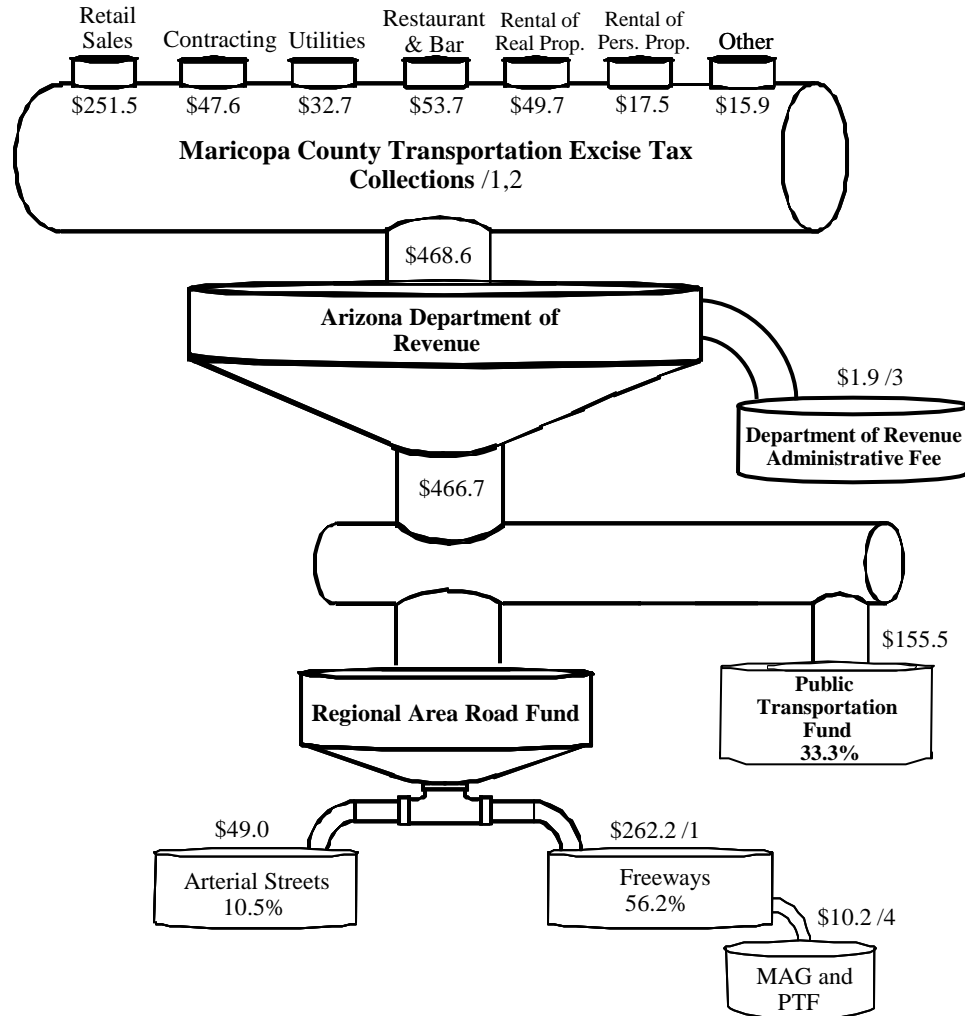

NOTES:

/1. Prop 300 expired on December 31, 2005 and Prop. 400 became effective on January 1, 2006. Collections and distributions are a mix of both Prop. 300 and Prop. 400. Prop. 300 monies will continue over time due to adjustments, refunds and audits. Prop. 300 revenues totaled a negative \$0.2 million in FY 2019.

/2. Under Prop. 400, the Regional Area Road Fund (ADOT) receives the Freeways 56.2% and the Arterial Streets 10.5% revenues. MAG programs projects for the Arterial Streets 10.5% monies and then ADOT is billed for the costs.

/3. Reflects the deduction from collections of a fee paid to the Arizona Department of Revenue pursuant to Arizona Revised Statutes Section 42-5041 to recover a portion of administrative, program and other operating costs incurred in collecting the transportation excise taxes.

/4. Per ARS 28-6305 B and C, portion of the Freeways 56.2% monies are distributed equally between MAG and the Public Transportation Fund to be used for planning and administering the regional transportation plan.

Note: Totals may not add due to rounding.