

TYPICAL SECTION  
(Case I, II, III)

ELEV (FEET)	Min Top Cover (FEET)
5000 and Below	1'-6"
Above 5000	2'-6"

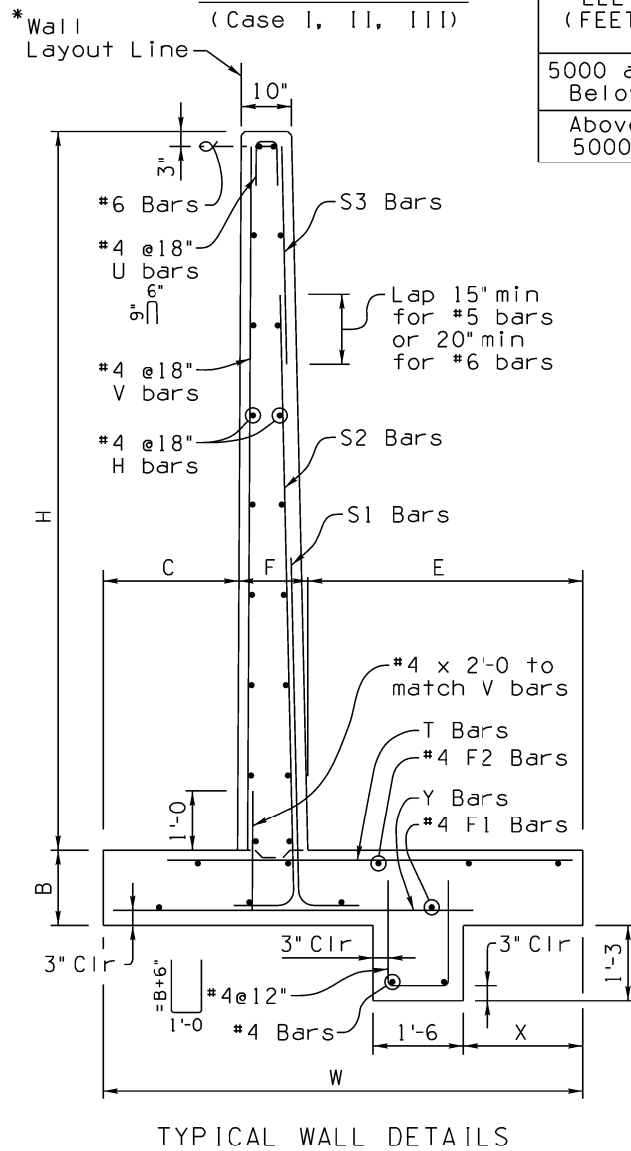

TYPICAL WALL DETAILS

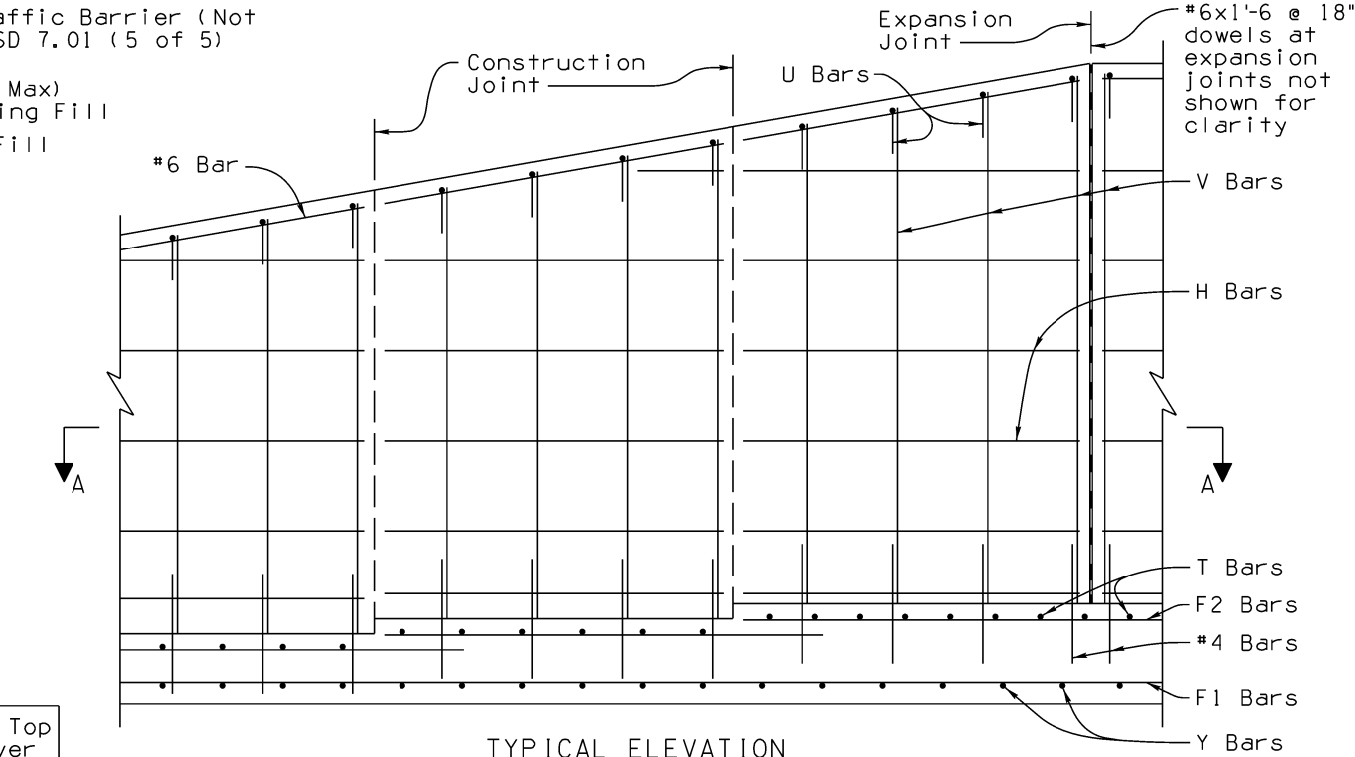

TYPICAL ELEVATION  
(Outside Face Reinforcing)

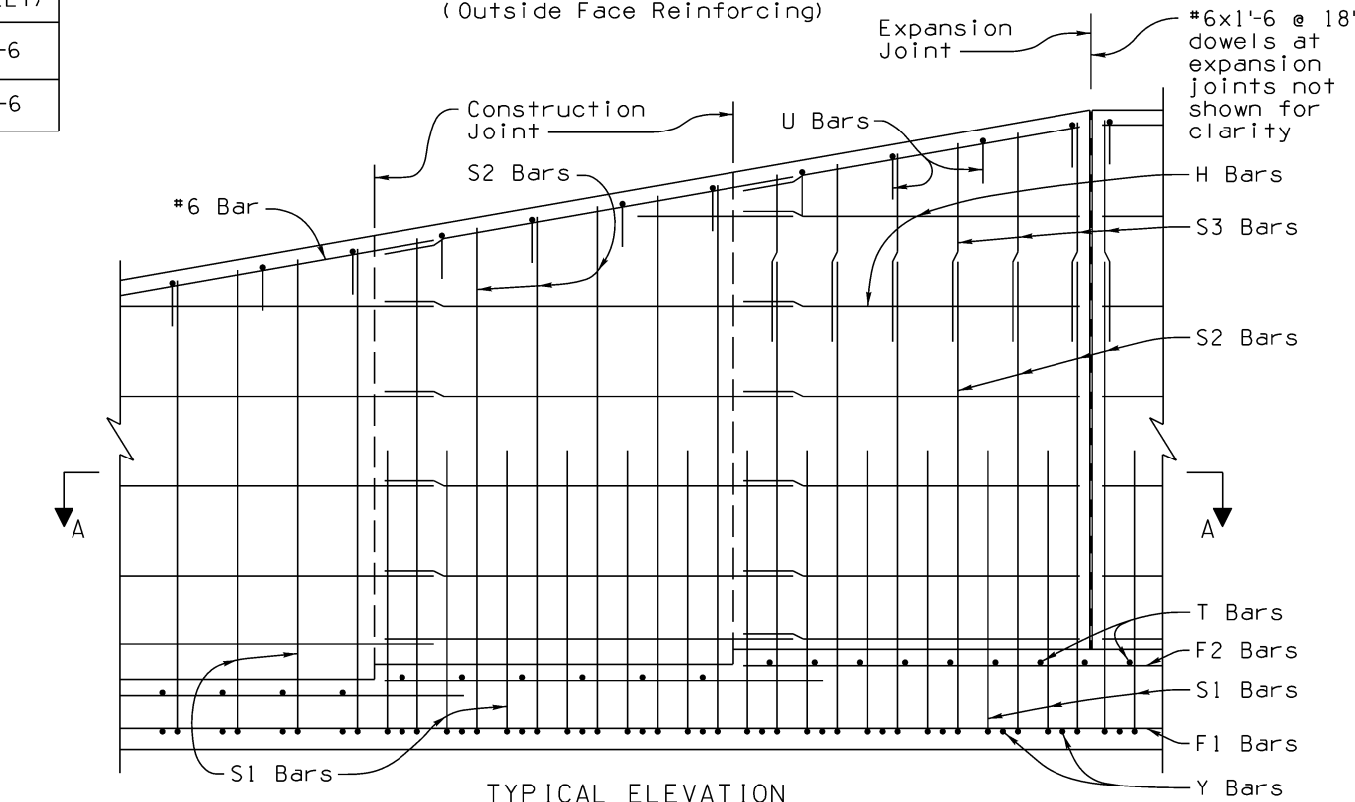

TYPICAL ELEVATION  
(Inside Face Reinforcing)

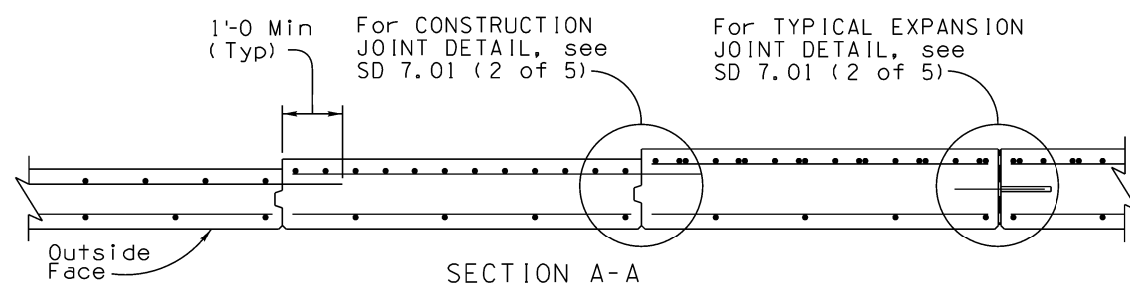

SECTION A-A

**GENERAL NOTES:**

Construction Specification - Arizona Department of Transportation Standard Specifications for Road and Bridge Construction, latest Edition.

Design Specifications - AASHTO LRFD Bridge Design Specifications, 8th Edition, 2017.

**Design:**

Soil weight = 120 p.c.f.  
Backfill angle of internal friction = 33°  
Existing ground angle of internal friction = 31°

All Concrete shall be Class "S" (f'c = 3000 psi).

Reinforcing steel shall conform to ASTM Specification A615. All reinforcing shall be furnished as Grade 60.

All bends and hooks shall meet the requirements of AASHTO LRFD Article 5.10. All bend dimensions for reinforcing steel shall be out-to-out of bars.

All placement dimensions for reinforcing steel shall be to center of bars unless noted otherwise.

All reinforcing steel shall have 2 inch clear cover unless noted otherwise.

Chamfer all exposed corners 3/4" unless noted otherwise.

Compact structure backfill for footing and wall base minimum 100 percent of ASTM D698 maximum dry density.

See Project Plans for wall layout, top of footing and finished grade elevations, footing step and wall joint locations. Construction Joints shall match the locations of contraction joints.

See Project Plans for wall surface treatment. Increase the wall thickness at the outside face for the depth of surface treatment.

Dimensions shall not be scaled from drawings.

Pay item measure of square foot of wall constructed will be measured along the front face of the wall from top of footing to top of wall cap.

\* See Project Plans for Wall Layout Line in relation to surface treatment.

Item	RETAINING WALL (REINFORCED CONCRETE CANTILEVER)
Item No.	9140178
Measure	Square Foot

**NOTES:**

For Retaining wall dimensions, quantities and additional details, see SD 7.01 sheets 2 thru 5.

For Structural Excavation and Structure Backfill Limits, see SD 7.01 (4 of 5).

Note to Designer: The information presented in this Standard Drawing has been prepared in accordance with recognized engineering principles and is for general use. It should not be used for specific application without competent professional examination and verification of its suitability and applicability by a licensed professional engineer. Contents within the inner border line shall not be altered.

PRIOR DISTRIBUTION DATE 12/21

STANDARDS ENGINEER	B. SINGH
RECOMMENDED FOR APPROVAL	D. BENTON
GROUP MANAGER	
APPROVED	
STANDARDS COMMITTEE APPROVED FOR DISTRIBUTION	10/24 DATE

ARIZONA DEPARTMENT OF TRANSPORTATION  
INFRASTRUCTURE DELIVERY AND OPERATIONS DIVISION  
**BRIDGE GROUP STANDARD DRAWING**

RETAINING WALL  
REINFORCED CONCRETE CANTILEVER

DRAWING NO.  
SD 7.01  
(1 of 5)

CASE I - LEVEL FILL

Dimensions							Steel List											Service Limit State				Strength Limit State									
H	W	B	C	F	E	X	S1			S2			S3			H	V	Y			F1	T			F2	Q <sub>tveu-SERV</sub> Lbs./Sq.Ft.	Q <sub>nveu-SERV</sub> Lbs./Sq.Ft.	B'SERV Ft.	Q <sub>tveu-STR</sub> Lbs./Sq.Ft.	Q <sub>nveu-STR</sub> Lbs./Sq.Ft.	B'STR Ft.
							Bar Size	Spacing	Length	Bar Size	Spacing	Length	Bar Size	Spacing	Length			Number	Length	Bar Size		Spacing	Length	Number							
4'	3'-0	1'-0	10"	10"	1'-4	8"	5	12"	5'-6						4	3'-9	5	12"	2'-3	2	5	12"	2'-3	3	840	480	2.46	1130	650	2.36	
5'	3'-6	1'-0	1'-0	10"	1'-8	9"	5	12"	6'-6						6	4'-9	5	12"	2'-9	2	5	12"	2'-9	3	920	560	2.91	1240	760	2.79	
6'	4'-0	1'-0	1'-2	10"	2'-0	10"	5	12"	7'-6						6	5'-9	5	12"	3'-3	2	5	12"	3'-3	3	1010	650	3.31	1380	900	3.16	
7'	4'-6	1'-0	1'-4	10"	2'-4	11"	5	12"	8'-6						8	6'-9	5	12"	3'-9	3	5	12"	3'-6	3	1110	750	3.70	1530	1040	3.52	
8'	5'-0	1'-2	1'-6	10"	2'-8	1'-0	5	12"	9'-9						10	7'-9	5	12"	4'-3	3	5	12"	4'-0	3	1270	890	4.01	1750	1240	3.79	
9'	5'-6	1'-2	1'-9	1'-0	2'-9	1'-2	5	12"	10'-9						10	8'-9	5	12"	4'-6	3	5	12"	4'-0	3	1350	970	4.40	1880	1370	4.14	
10'	6'-0	1'-2	1'-9	1'-0	3'-3	1'-4	6	12"	11'-9						12	9'-9	5	12"	4'-9	3	5	12"	4'-6	4	1510	1130	4.73	2100	1590	4.45	
11'	6'-6	1'-2	2'-0	1'-0	3'-6	1'-6	5	12"	4'-3	5	12"	12'-9			14	10'-9	5	12"	5'-3	4	5	12"	4'-9	4	1590	1210	5.12	2230	1710	4.81	
12'	7'-0	1'-3	2'-0	1'-0	4'-0	1'-8	6	12"	5'-3	5	12"	13'-9			14	11'-9	5	12"	5'-6	4	6	12"	5'-6	5	1770	1380	5.42	2490	1960	5.08	
13'	7'-6	1'-3	2'-3	1'-0	4'-3	1'-10	7	12"	6'-6	5	12"	14'-9			16	12'-9	5	12"	5'-9	4	6	9"	5'-9	5	1860	1470	5.81	2620	2090	5.43	
14'	8'-0	1'-3	2'-3	1'-2	4'-7	2'-0	7	12"	7'-0	5	12"	15'-9			18	13'-9	5	12"	6'-3	4	7	12"	6'-9	5	2020	1630	6.14	2850	2320	5.74	
15'	8'-6	1'-3	2'-6	1'-3	4'-9	2'-2	7	12"	8'-0	5	12"	16'-9			18	14'-9	6	12"	6'-6	5	7	12"	7'-0	5	2100	1710	6.53	2970	2450	6.10	
16'	9'-0	1'-4	2'-6	1'-4	5'-2	2'-4	7	12"	7'-3	6	12"	8'-9	5	12"	20	15'-9	6	12"	6'-9	5	8	12"	8'-3	6	2300	1900	6.82	3250	2710	6.36	
17'	9'-6	1'-4	2'-9	1'-5	5'-4	2'-6	7	12"	6'-0	7	12"	9'-9	5	12"	22	16'-9	6	9"	7'-3	5	8	12"	8'-6	6	2380	1980	7.21	3380	2840	6.72	
18'	10'-0	1'-5	2'-9	1'-6	5'-9	2'-8	7	12"	7'-0	7	12"	10'-6	5	12"	22	17'-9	6	9"	7'-6	5	7	8"	8'-6	6	2580	2170	7.50	3660	3110	6.99	
19'	10'-6	1'-6	3'-0	1'-7	5'-11	2'-10	8	12"	8'-0	7	12"	10'-3	6	12"	24	18'-9	6	9"	8'-0	6	8	9"	9'-3	7	2690	2270	7.86	3830	3260	7.30	
20'	11'-0	1'-6	3'-0	1'-8	6'-4	3'-0	8	12"	7'-6	8	12"	11'-6	6	12"	26	19'-9	6	8"	8'-3	6	8	8"	9'-6	7	2860	2440	8.19	4070	3500	7.61	
21'	11'-6	1'-7	3'-3	1'-9	6'-6	3'-2	8	12"	8'-3	8	12"	12'-6	6	12"	26	20'-9	7	12"	8'-9	6	9	9"	10'-6	7	2970	2540	8.54	4240	3660	7.92	
22'	12'-0	1'-8	3'-3	1'-10	6'-11	3'-4	9	12"	9'-6	8	12"	13'-6	6	12"	28	21'-9	7	12"	9'-0	6	9	9"	11'-0	7	3180	2740	8.83	4530	3940	8.18	
23'	12'-6	1'-9	3'-6	2'-0	7'-0	3'-6	10	12"	12'-3	7	12"	14'-0	6	12"	30	22'-9	8	12"	9'-3	6	8	6"	10'-3	7	3290	2840	9.18	4700	4100	8.49	
24'	13'-0	1'-10	3'-6	2'-2	7'-4	3'-8	9	12"	9'-3	9	12"	15'-6	6	12"	30	23'-9	8	12"	9'-6	7	8	6"	10'-6	8	3500	3040	9.47	5000	4380	8.76	
25'	13'-6	2'-0	3'-9	2'-4	7'-5	3'-10	9	12"	10'-3	9	12"	16'-6	6	12"	32	24'-9	8	12"	10'-0	7	8	6"	10'-9	8	3650	3170	9.78	5220	4580	9.02	
26'	14'-0	2'-3	3'-9	2'-6	7'-9	4'-0	10	12"	13'-0	8	12"	17'-6	6	12"	34	25'-9	8	12"	10'-3	7	8	6"	11'-0	8	3920	3410	9.99	5630	4940	9.19	
27'	14'-6	2'-6	4'-0	2'-8	7'-10	4'-2	10	12"	12'-3	9	12"	18'-6	6	12"	34	26'-9	8	12"	10'-6	7	8	6"	11'-0	8	4110	3570	10.26	5910	5180	9.41	
28'	15'-0	2'-9	4'-0	2'-10	8'-2	4'-4	10	12"	13'-3	9	12"	19'-9	6	12"	36	27'-9	8	12"	11'-0	7	8	6"	11'-6	8	4390	3820	10.47	6330	5550	9.58	
29'	15'-6	3'-0	4'-3	3'-0	8'-3	4'-6	10	12"	12'-0	10	12"	21'-0	6	12"	38	28'-9	8	12"	11'-3	7	8	6"	11'-9	9	4580	3980	10.73	6610	5800	9.79	
30'	16'-0	3'-3	4'-3	3'-2	8'-7	4'-8	10	12"	13'-0	10	12"	22'-3	6	12"	38	29'-9	8	12"	11'-6	8	8	6"	11'-9	9	4860	4230	10.94	7040	6180	9.97	

QUANTITIES

CASE I			
H	Concrete C.Y./Ln.Ft.	Steel Lbs./Ln.Ft.	Steel (Horiz. Lap) Lbs./Splice
4'	.30	27	10
5'	.35	31	12
6'	.40	33	12
7'	.45	38	14
8'	.53	42	15
9'	.61	44	15
10'	.67	53	17
11'	.72	57	19
12'	.80	66	20
13'	.86	78	21
14'	.96	84	22
15'	1.04	92	23
16'	1.16	108	25
17'	1.25	119	26
18'	1.37	128	26
19'	1.50	153	29
20'	1.61	171	30
21'	1.75	185	30
22'	1.90	203	32
23'	2.09	229	33
24'	2.29	236	34
25'	2.54	248	36
26'	2.84	264	37
27'	3.16	279	37
28'	3.50	294	38
29'	3.85	317	40
30'	4.22	328	41

LIMIT STATE NOTES:

- Q<sub>tveu-SERV</sub> = Total equivalent uniform vertical bearing stress to be used only for the evaluation of settlement based on the Service I Limit State as per ADOT SF-1.
- Q<sub>nveu-SERV</sub> = Net equivalent uniform vertical bearing stress to be used only for the evaluation of settlement based on the Service I Limit State as per ADOT SF-1.
- B'SERV = Effective footing width to be used only for the evaluation of settlement based on the Service I Limit State as per ADOT SF-1.
- Q<sub>tveu-STR</sub> = Total equivalent uniform vertical bearing stress to be used only for the evaluation of bearing resistance based on the Strength I Limit State as per ADOT SF-1.
- Q<sub>nveu-STR</sub> = Net equivalent uniform vertical bearing stress to be used only for the evaluation of bearing resistance based on the Strength I Limit State as per ADOT SF-1.
- B'STR = Effective footing width to be used only for the evaluation of bearing resistance based on the Strength I Limit State as per ADOT SF-1.

For other applicable limit states, perform project specific analysis using the procedures in ADOT SF-1 (Spread Footing: Bearing Resistance and Settlement).

ADOT SF-1 memorandum is found on the Bridge Group website (Geotech Services LRF Design Memorandums).

QUANTITIES NOTE:

Quantities are shown for information purposes only. The pay item is measured per square foot of wall.

Quantities are for one L.F. of wall except for horizontal steel lap splices and footing steps.

Steel quantities for horizontal lap splices shall be added for wall segments greater than 30 feet, and add a splice for each additional wall segment greater than 30 feet. Horizontal 1'-0 lap splices occur at construction or contraction joints.

Steel and concrete quantities for footing steps shall be added to those shown in the table.

DOWEL NOTE:

Dowel placement includes furnishing and placing PVC pipe sleeves in the concrete forms, and placing metal dowels in the PVC pipe sleeves.

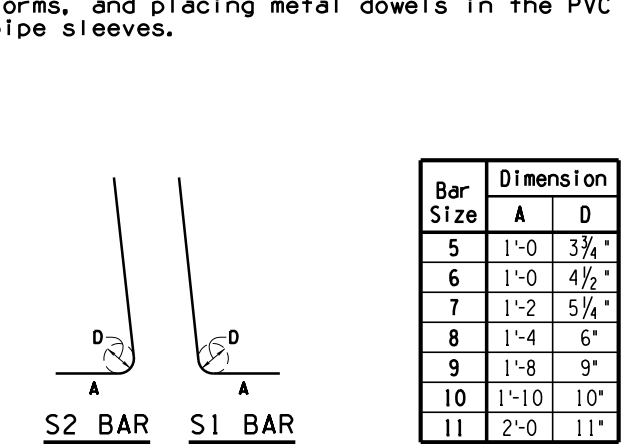
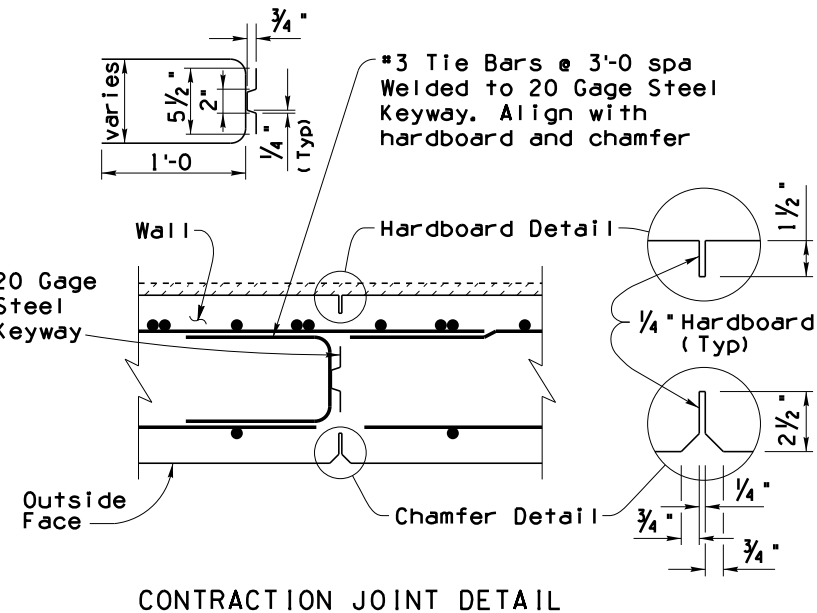
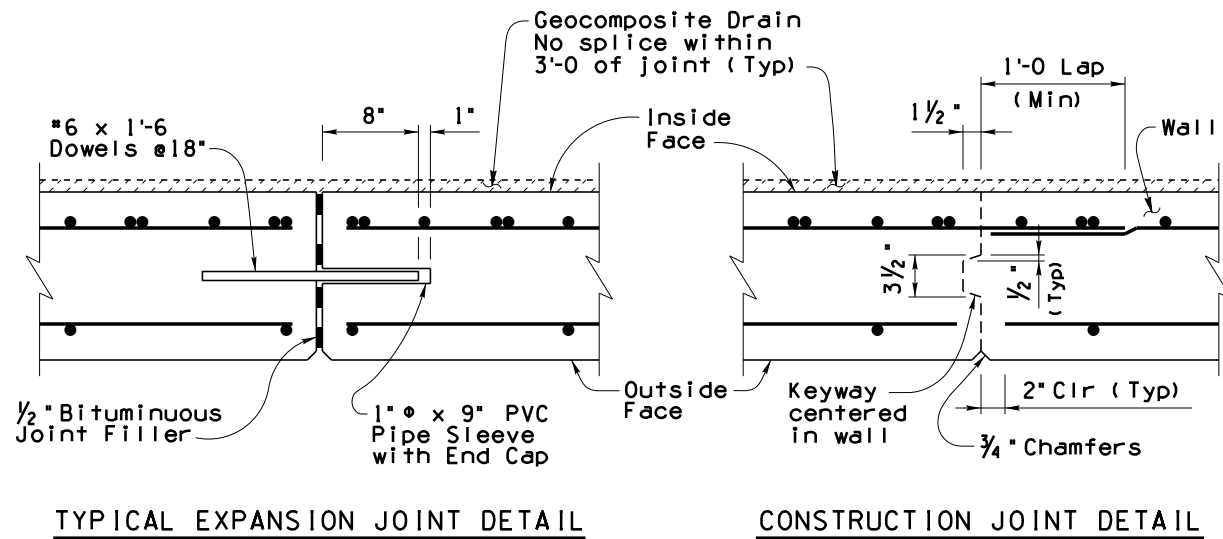

JOINT NOTES:

- All retaining walls shall have construction joints or contraction joints spaced at not more than 30'-0 apart or as shown. Contraction joints may be substituted for construction joints for wall pours longer than 30'-0.
- Expansion joints shall be provided at intervals not exceeding 90'-0.
- Footings may be continuous with no joints (except at footing step locations).

NOTES:

- For General Notes, Typical Elevations, Sections and Details see SD 7.01 (1, 3, and 4).
- For Structural Excavation Limits and Structure Backfill Limits, see SD 7.01 (4 of 5).

STANDARDS ENGINEER  
**A. ALZUBI**  
 RECOMMENDED FOR APPROVAL  
 GROUP MANAGER  
**D. EBERHART**  
 APPROVED  
 STANDARDS COMMITTEE APPROVED FOR DISTRIBUTION

ARIZONA DEPARTMENT OF TRANSPORTATION  
 INFRASTRUCTURE DELIVERY AND OPERATIONS DIVISION  
 BRIDGE GROUP STANDARD DRAWING

**RETAINING WALL  
 REINFORCED CONCRETE CANTILEVER**

DRAWING NO.  
**SD 7.01  
 (2 of 5)**

Note to Designer: The information presented in this Standard Drawing has been prepared in accordance with recognized engineering principles and is for general use. It should not be used for specific application without competent professional examination and verification of its suitability and applicability by a licensed professional engineer. Contents within the inner border line shall not be altered.

PRIOR DISTRIBUTION DATE 01/15

CASE II-LEVEL FILL WITH 2' SURCHARGE (TRAFFIC)

QUANTITIES

LIMIT STATE NOTES:

Dimensions							Steel List												Service Limit State			Strength Limit State									
H	W	B	C	F	E	X	S1			S2			S3			H	V	Y			F1	T			F2	Qtveu-SERV Lbs./Sq.Ft.	Qnveu-SERV Lbs./Sq.Ft.	B'SERV Ft.	Qtveu-STR Lbs./Sq.Ft.	Qnveu-STR Lbs./Sq.Ft.	B'STR Ft.
							Bar Size	Spacing	Length	Bar Size	Spacing	Length	Bar Size	Spacing	Length			Number $\Phi$	Length	Bar Size		Spacing	Length	Number $\Phi$							
4'	3'-6"	1'-0"	1'-0"	10"	1'-8"	1'-0"	5	12"	5'-6"						4	3'-9"	5	12"	2'-6"	2	5	12"	3'-0"	3	980	620	2.79	1420	930	2.64	
5'	4'-0"	1'-0"	1'-2"	10"	2'-0"	1'-0"	5	12"	6'-6"						6	4'-9"	5	12"	3'-0"	2	5	12"	3'-3"	3	1090	730	3.18	1580	1100	2.98	
6'	4'-6"	1'-0"	1'-4"	10"	2'-4"	1'-2"	5	12"	7'-6"						6	5'-9"	5	12"	3'-6"	3	5	12"	3'-9"	3	1210	850	3.53	1770	1280	3.29	
7'	5'-1"	1'-2"	1'-6"	10"	2'-9"	1'-4"	6	12"	8'-9"						8	6'-9"	5	12"	3'-9"	3	5	12"	4'-0"	3	1370	990	3.93	2010	1490	3.65	
8'	5'-8"	1'-2"	1'-8"	10"	3'-2"	1'-6"	6	9"	9'-9"						10	7'-9"	5	12"	4'-3"	3	5	12"	4'-6"	3	1470	1090	4.41	2150	1640	4.10	
9'	6'-3"	1'-2"	1'-10"	1'-0"	3'-5"	1'-8"	6	9"	10'-9"						10	8'-9"	5	12"	4'-9"	3	5	12"	4'-9"	4	1560	1180	4.89	2280	1770	4.55	
10'	6'-10"	1'-3"	2'-0"	1'-0"	3'-10"	1'-9"	7	12"	12'-0"						12	9'-9"	5	12"	5'-3"	4	6	12"	5'-3"	4	1690	1300	5.35	2470	1940	4.97	
11'	7'-6"	1'-3"	2'-3"	1'-0"	4'-3"	1'-10"	6	12"	4'-9"	6	12"	12'-9"			14	10'-9"	5	12"	5'-9"	4	7	12"	6'-3"	5	1750	1360	5.99	2550	2020	5.59	
12'	8'-0"	1'-3"	2'-3"	1'-2"	4'-7"	2'-0"	6	12"	5'-0"	6	12"	13'-9"			14	11'-9"	5	12"	6'-0"	4	7	12"	6'-9"	5	1840	1450	6.36	2680	2150	5.92	
13'	8'-6"	1'-3"	2'-6"	1'-3"	4'-9"	2'-2"	7	12"	7'-6"	5	12"	14'-9"			16	12'-9"	6	12"	6'-6"	4	8	12"	7'-9"	5	2000	1610	6.70	2910	2390	6.23	
14'	9'-0"	1'-3"	2'-6"	1'-4"	5'-2"	2'-4"	7	12"	7'-3"	6	12"	15'-9"			18	13'-9"	6	12"	6'-9"	5	8	12"	8'-3"	6	2160	1770	7.02	3150	2620	6.53	
15'	9'-6"	1'-4"	2'-9"	1'-5"	5'-4"	2'-6"	8	12"	8'-9"	6	12"	17'-0"			18	14'-9"	6	9"	7'-0"	5	8	12"	8'-6"	6	2280	1880	7.36	3320	2780	6.83	
16'	10'-0"	1'-5"	2'-9"	1'-6"	5'-9"	2'-8"	7	12"	7'-0"	7	12"	9'-0"	6	12"	10'-9"	20	15'-9"	6	8"	7'-3"	5	7	8"	8'-0"	6	2470	2060	7.65	3610	3060	7.08
17'	10'-6"	1'-6"	3'-0"	1'-7"	5'-11"	2'-10"	8	12"	8'-0"	7	12"	9'-0"	6	12"	10'-9"	22	16'-9"	6	8"	7'-9"	5	7	8"	8'-3"	6	2590	2170	7.99	3790	3220	7.38
18'	11'-0"	1'-7"	3'-0"	1'-8"	6'-4"	3'-0"	7	10"	7'-6"	7	10"	10'-0"	6	10"	11'-9"	22	17'-9"	7	12"	8'-0"	6	9	10"	10'-0"	7	2790	2360	8.28	4080	3500	7.64
19'	11'-6"	1'-8"	3'-3"	1'-9"	6'-6"	3'-2"	8	12"	8'-0"	8	12"	12'-6"	6	12"	10'-9"	24	18'-9"	7	12"	8'-6"	6	8	8"	9'-6"	7	2900	2460	8.62	4250	3660	7.93
20'	12'-0"	1'-9"	3'-3"	1'-10"	6'-11"	3'-4"	9	12"	9'-6"	8	12"	13'-3"	6	12"	11'-0"	26	19'-9"	7	12"	8'-9"	6	9	9"	10'-9"	7	3110	2660	8.91	4550	3940	8.20
21'	12'-6"	1'-10"	3'-6"	1'-11"	7'-1"	3'-6"	8	10"	9'-0"	8	10"	14'-3"	6	10"	11'-3"	26	20'-9"	7	10"	9'-0"	6	10	10"	11'-9"	7	3220	2760	9.25	4720	4100	8.49
22'	13'-0"	1'-11"	3'-6"	2'-0"	7'-6"	3'-8"	9	12"	10'-0"	9	12"	15'-9"	6	12"	11'-0"	28	21'-9"	8	12"	9'-6"	6	8	6"	10'-6"	7	3420	2950	9.54	5020	4390	8.76
23'	13'-6"	2'-0"	3'-9"	2'-2"	7'-7"	3'-10"	10	12"	12'-9"	8	12"	16'-3"	6	12"	11'-3"	30	22'-9"	8	12"	9'-9"	7	8	6"	10'-9"	7	3540	3060	9.89	5190	4550	9.05
24'	14'-0"	2'-2"	3'-9"	2'-4"	7'-11"	4'-0"	10	12"	11'-6"	9	12"	17'-9"	6	12"	11'-3"	30	23'-9"	8	12"	10'-3"	7	8	6"	11'-0"	8	3780	3280	10.13	5550	4870	9.27
25'	14'-6"	2'-4"	4'-0"	2'-6"	8'-0"	4'-2"	10	12"	12'-6"	9	12"	19'-0"	6	12"	11'-3"	32	24'-9"	8	12"	10'-6"	7	8	6"	11'-3"	8	3930	3410	10.43	5770	5070	9.51
26'	15'-0"	2'-6"	4'-0"	2'-8"	8'-4"	4'-4"	9	10"	11'-6"	9	10"	18'-6"	6	10"	13'-0"	34	25'-9"	8	12"	11'-0"	7	10	9"	13'-0"	9	4170	3630	10.68	6130	5400	9.73
27'	15'-6"	2'-9"	4'-3"	2'-10"	8'-5"	4'-6"	10	12"	12'-3"	10	12"	21'-3"	6	12"	11'-9"	34	26'-9"	8	12"	11'-6"	8	10	9"	13'-3"	9	4360	3790	10.94	6420	5650	9.93
28'	16'-0"	3'-0"	4'-3"	3'-0"	8'-9"	4'-8"	10	12"	13'-3"	10	12"	22'-0"	6	12"	12'-3"	36	27'-9"	8	12"	11'-6"	8	10	9"	13'-6"	9	4640	4040	11.14	6840	6030	10.10
29'	16'-6"	3'-3"	4'-6"	3'-3"	8'-9"	4'-10"	11	12"	16'-3"	9	12"	23'-0"	6	12"	12'-3"	38	28'-9"	8	12"	12'-0"	8	10	9"	13'-9"	9	4830	4200	11.40	7130	6280	10.29
30'	17'-0"	3'-6"	4'-6"	3'-6"	9'-0"	5'-0"	11	12"	15'-9"	10	12"	24'-0"	6	12"	12'-9"	38	29'-9"	8	12"	12'-6"	8	10	9"	14'-0"	10	5120	4460	11.61	7560	6670	10.46

CASE II			
H	Concrete C.Y./Ln.Ft.	Steel Lbs./Ln.Ft.	Steel (Horiz. Lap) Lbs./Splice
4'	.32	28	10
5'	.37	32	12
6'	.42	35	12
7'	.51	43	14
8'	.56	52	15
9'	.65	56	16
10'	.73	65	18
11'	.79	74	20
12'	.88	78	20
13'	.96	93	21
14'	1.05	105	24
15'	1.16	121	24
16'	1.29	127	25
17'	1.41	138	26
18'	1.55	162	28
19'	1.69	169	29
20'	1.83	195	30
21'	1.99	223	30
22'	2.15	233	32
23'	2.35	248	34
24'	2.60	264	34
25'	2.87	276	36
26'	3.14	305	38
27'	3.48	326	38
28'	3.83	337	40
29'	4.25	355	41
30'	4.68	383	42

Qtveu-SERV = Total equivalent uniform vertical bearing stress to be used only for the evaluation of settlement based on the Service I Limit State as per ADOT SF-1.

Qnveu-SERV = Net equivalent uniform vertical bearing stress to be used only for the evaluation of settlement based on the Service I Limit State as per ADOT SF-1.

B' SERV = Effective footing width to be used only for the evaluation of settlement based on the Service I Limit State as per ADOT SF-1.

Qtveu-STR = Total equivalent uniform vertical bearing stress to be used only for the evaluation of bearing resistance based on the Strength I Limit State as per ADOT SF-1.

Qnveu-STR = Net equivalent uniform vertical bearing stress to be used only for the evaluation of bearing resistance based on the Strength I Limit State as per ADOT SF-1.

B' STR = Effective footing width to be used only for the evaluation of bearing resistance based on the Strength I Limit State as per ADOT SF-1.

For other applicable limit states, perform project specific-analysis using the procedures in ADOT SF-1 (Spread Footing: Bearing Resistance and Settlement).

ADOT SF-1 memorandum is found on the Bridge Group website (Geotech Services LRF Design Memorandums).

QUANTITIES NOTE:

Quantities are shown for information purposes only. The pay item is measured per square foot of wall.

Quantities are for one L.F. of wall except for horizontal steel lap splices and footing steps.

Steel quantities for horizontal lap splices shall be added for wall segments greater than 30 feet, and add a splice for each additional wall segment greater than 30 feet. Horizontal 1'-0" lap splices occur at construction or contraction joints.

Steel and concrete quantities for footing steps shall be added to those shown in the table.

NOTES:

For General Notes, Typical Elevations, Sections and Details see SD 7.01 (1, 2, and 4).

For Structural Excavation Limits and Structure Backfill Limits, see SD 7.01 (4 of 5).

$\Phi$  Total number of bars in cross section.

\* Total number includes the sum of both faces.

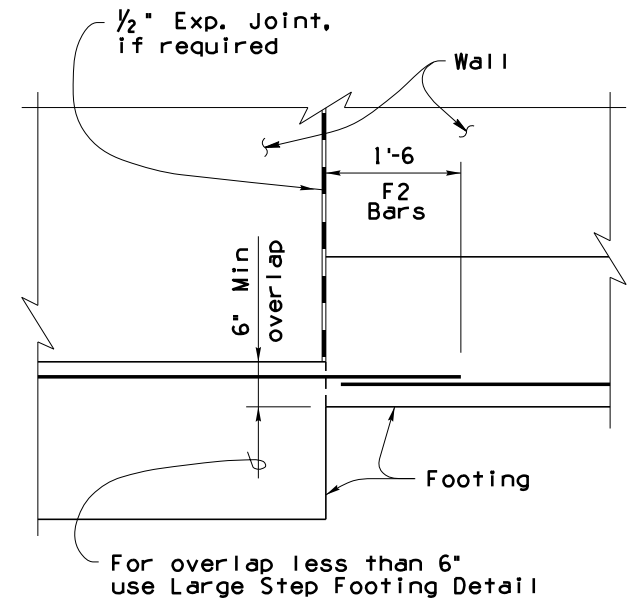

SMALL STEP FOOTING DETAIL

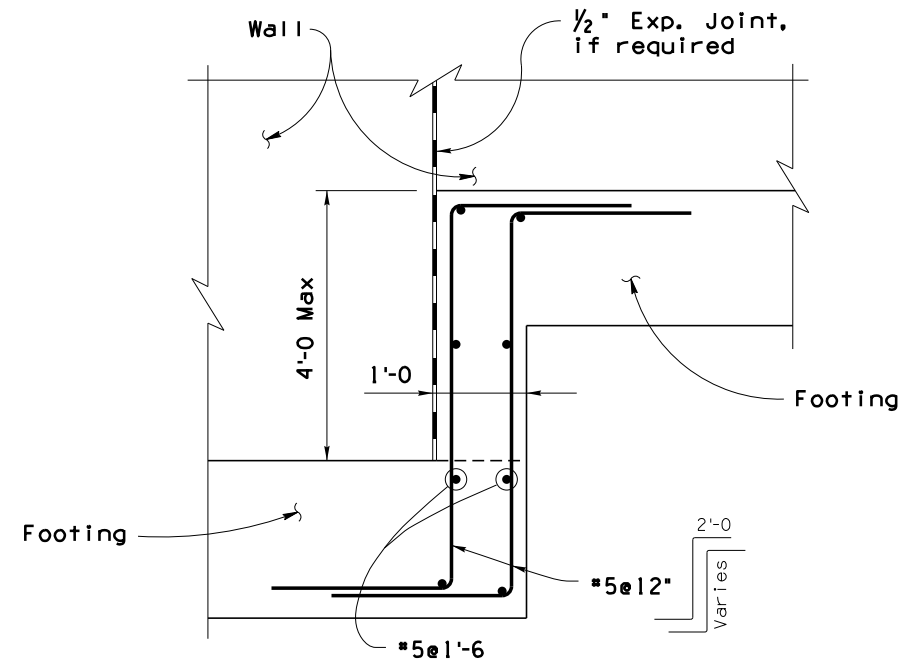

LARGE STEP FOOTING DETAIL

Note to Designer: The information presented in this Standard Drawing has been prepared in accordance with recognized engineering principles and is for general use. It should not be used for specific application without competent professional examination and verification of its suitability and applicability by a licensed professional engineer. Contents within the inner border line shall not be altered.

PRIOR DISTRIBUTION DATE 01/15

STANDARDS ENGINEER  
**A. ALZUBI**  
RECOMMENDED FOR APPROVAL  
GROUP MANAGER  
**D. EBERHART**  
APPROVED  
STANDARDS COMMITTEE APPROVED FOR DISTRIBUTION 12/21  
DATE

ARIZONA DEPARTMENT OF TRANSPORTATION  
INFRASTRUCTURE DELIVERY AND OPERATIONS DIVISION  
BRIDGE GROUP STANDARD DRAWING

RETAINING WALL  
REINFORCED CONCRETE CANTILEVER  
DRAWING NO.  
**SD 7.01**  
**(3 of 5)**

CASE III - 2:1 (MAX) SLOPING FILL

QUANTITIES

LIMIT STATE NOTES:

Dimensions							Steel List										Service Limit State			Strength Limit State											
H	W	B	C	F	E	X	S1			S2			S3			H	V	Y			F1	T			F2	Q <sub>tveu-SERV</sub> Lbs./Sq.Ft.	Q <sub>nveu-SERV</sub> Lbs./Sq.Ft.	B'SERV Ft.	Q <sub>tveu-STR</sub> Lbs./Sq.Ft.	Q <sub>nveu-STR</sub> Lbs./Sq.Ft.	B'STR Ft.
							Bar Size	Spacing	Length	Bar Size	Spacing	Length	Bar Size	Spacing	Length			Number	Length	Bar Size		Spacing	Length	Number							
4'	3'-0	1'-0	1'-0	10"	1'-2	1'-0	5	12"	5'-6						4	3'-9	5	12"	2'-0	2	5	12"	2'-6	3	960	600	2.52	1320	830	2.44	
5'	3'-6	1'-0	1'-0	10"	1'-8	1'-0	5	12"	6'-6						6	4'-9	5	12"	2'-6	2	5	12"	3'-0	3	1140	780	2.90	1570	1080	2.80	
6'	4'-2	1'-0	1'-0	10"	2'-4	1'-0	5	12"	7'-6						6	5'-9	5	12"	3'-3	2	5	12"	3'-9	3	1300	940	3.46	1810	1320	3.34	
7'	5'-0	1'-2	1'-2	10"	3'-0	1'-3	5	12"	8'-9						8	6'-9	5	12"	3'-9	3	5	12"	4'-3	4	1470	1090	4.19	2040	1530	4.05	
8'	5'-9	1'-2	1'-4	10"	3'-7	1'-6	6	12"	9'-9						10	7'-9	5	12"	4'-3	3	6	12"	5'-0	4	1600	1220	4.89	2220	1710	4.73	
9'	6'-6	1'-3	1'-6	1'-0	4'-0	1'-9	6	12"	10'-9						10	8'-9	5	12"	4'-9	3	6	9"	5'-6	5	1760	1370	5.55	2450	1930	5.37	
10'	7'-3	1'-3	1'-8	1'-0	4'-7	2'-0	7	12"	12'-0						12	9'-9	5	12"	5'-3	4	7	12"	6'-9	5	1890	1500	6.25	2640	2110	6.06	
11'	8'-3	1'-4	1'-10	1'-2	5'-3	2'-3	7	12"	13'-0						14	10'-9	5	12"	6'-0	4	8	12"	7'-9	6	2030	1630	7.25	2830	2290	7.04	
12'	9'-0	1'-4	2'-0	1'-2	5'-10	2'-6	7	12"	14'-0						14	11'-9	5	12"	6'-6	4	8	12"	8'-6	7	2170	1770	7.95	3020	2480	7.73	
13'	9'-9	1'-6	2'-2	1'-4	6'-3	2'-9	6	12"	6'-3	6	12"	15'-0			16	12'-9	5	12"	7'-0	5	8	9"	9'-3	8	2360	1940	8.58	3290	2730	8.34	
14'	10'-6	1'-8	2'-4	1'-4	6'-10	3'-0	7	12"	8'-6	6	12"	16'-3			18	13'-9	5	12"	7'-6	5	7	6"	9'-0	8	2550	2110	9.22	3560	2970	8.95	
15'	11'-3	1'-10	2'-6	1'-4	7'-5	3'-2	7	14"	6'-6	7	14"	17'-6			18	14'-9	6	14"	8'-3	5	8	7"	10'-9	9	2740	2280	9.86	3830	3210	9.56	
16'	12'-0	2'-0	2'-8	1'-6	7'-10	3'-4	7	12"	6'-9	7	12"	10'-3	5	12"	20	15'-9	5	12"	8'-9	6	8	6"	11'-0	9	2940	2460	10.49	4110	3460	10.18	
17'	12'-6	2'-2	2'-8	1'-6	8'-4	3'-6	8	14"	7'-9	8	14"	11'-0	6	14"	22	16'-9	6	14"	9'-3	6	9	7"	12'-0	9	3220	2720	10.72	4510	3840	10.37	
18'	13'-0	2'-4	2'-10	1'-6	8'-8	3'-8	8	12"	8'-3	8	12"	11'-6	6	12"	22	17'-9	6	12"	9'-6	6	9	6"	12'-6	10	3440	2920	11.02	4830	4130	10.64	
19'	13'-6	2'-6	2'-10	1'-8	9'-0	3'-10	9	14"	8'-9	9	14"	13'-6	6	14"	24	18'-9	6	12"	9'-9	7	9	6"	13'-0	10	3730	3190	11.24	5260	4530	10.83	
20'	14'-0	2'-8	3'-0	1'-10	9'-2	4'-0	9	14"	9'-6	9	14"	14'-3	6	14"	26	19'-9	6	12"	10'-3	7	10	7"	13'-6	11	3960	3400	11.53	5590	4840	11.10	
21'	14'-6	2'-10	3'-2	2'-0	9'-4	4'-2	9	12"	9'-6	9	12"	14'-9	6	12"	26	20'-9	6	12"	10'-6	7	10	6"	14'-0	11	4200	3620	11.82	5930	5150	11.36	
22'	15'-0	3'-0	3'-2	2'-2	9'-8	4'-4	9	12"	10'-3	9	12"	15'-9	6	12"	28	21'-9	7	12"	11'-0	8	10	6"	14'-6	11	4510	3910	12.04	6380	5570	11.54	
23'	15'-8	3'-4	3'-4	2'-4	10'-0	4'-6	9	12"	11'-3	9	12"	16'-9	6	12"	30	22'-9	7	12"	11'-6	8	10	6"	14'-9	12	4790	4150	12.48	6780	5920	11.96	
24'	16'-4	3'-8	3'-6	2'-6	10'-4	4'-8	10	14"	11'-9	10	14"	19'-0	6	14"	30	23'-9	7	12"	12'-0	8	11	7"	15'-9	12	5070	4390	12.93	7190	6270	12.37	
25'	17'-0	4'-0	3'-8	2'-9	10'-7	4'-10	10	12"	13'-0	9	12"	19'-3	6	12"	32	24'-9	7	12"	12'-6	8	11	6"	16'-6	12	5350	4630	13.38	7590	6620	12.79	
26'	17'-6	4'-4	3'-10	3'-0	10'-8	5'-0	10	12"	13'-9	9	12"	20'-3	6	12"	34	25'-9	7	12"	13'-0	9	11	6"	17'-0	13	5670	4910	13.59	8060	7030	12.96	
27'	18'-0	4'-8	4'-0	3'-3	10'-9	5'-2	10	12"	15'-0	9	12"	21'-3	6	12"	34	26'-9	7	12"	13'-0	9	11	6"	17'-6	13	6000	5200	13.81	8540	7460	13.14	
28'	18'-8	5'-0	4'-3	3'-6	10'-11	5'-4	10	12"	13'-9	10	12"	22'-9	6	12"	36	27'-9	7	12"	13'-6	9	11	6"	17'-9	13	6240	5400	14.29	8890	7760	13.59	
29'	19'-4	5'-4	4'-6	3'-9	11'-1	5'-6	10	12"	14'-9	10	12"	24'-0	6	12"	38	28'-9	7	12"	14'-0	10	11	6"	17'-9	13	6490	5610	14.77	9250	8060	14.03	
30'	20'-0	5'-8	4'-9	4'-0	11'-3	5'-8	10	12"	15'-9	10	12"	25'-3	6	12"	38	29'-9	7	12"	14'-6	10	11	6"	18'-0	13	6740	5820	15.25	9600	8360	14.48	

CASE III			
H	Concrete C.Y./Ln.Ft.	Steel Lbs./Ln.Ft.	Steel (Horiz. Lap) Lbs./Splice
4'	.30	27	10
5'	.35	31	12
6'	.41	34	12
7'	.50	40	14
8'	.56	50	16
9'	.68	57	16
10'	.74	71	18
11'	.88	84	20
12'	.96	89	21
13'	1.13	107	24
14'	1.28	123	25
15'	1.44	140	26
16'	1.65	154	28
17'	1.81	181	29
18'	1.97	213	30
19'	2.20	229	32
20'	2.44	248	34
21'	2.69	292	34
22'	2.96	314	36
23'	3.35	320	38
24'	3.77	353	38
25'	4.25	400	39
26'	4.72	417	42
27'	5.22	432	42
28'	5.77	459	43
29'	6.35	473	45
30'	6.95	487	45

Q<sub>tveu-SERV</sub> = Total equivalent uniform vertical bearing stress to be used only for the evaluation of settlement based on the Service I Limit State as per ADOT SF-1.

Q<sub>nveu-SERV</sub> = Net equivalent uniform vertical bearing stress to be used only for the evaluation of settlement based on the Service I Limit State as per ADOT SF-1.

B'SERV = Effective footing width to be used only for the evaluation of settlement based on the Service I Limit State as per ADOT SF-1.

Q<sub>tveu-STR</sub> = Total equivalent uniform vertical bearing stress to be used only for the evaluation of bearing resistance based on the Strength I Limit State as per ADOT SF-1.

Q<sub>nveu-STR</sub> = Net equivalent uniform vertical bearing stress to be used only for the evaluation of bearing resistance based on the Strength I Limit State as per ADOT SF-1.

B'STR = Effective footing width to be used only for the evaluation of bearing resistance based on the Strength I Limit State as per ADOT SF-1.

For other applicable limit states, perform project specific-analysis using the procedures in ADOT SF-1 (Spread Footing: Bearing Resistance and Settlement).

ADOT SF-1 memorandum is found on the Bridge Group website (Geotech Services LRF Design Memorandums).

QUANTITIES NOTE:

Quantities are shown for information purposes only. The pay item is measured per square foot of wall.

Quantities are for one L.F. of wall except for horizontal steel lap splices and footing steps.

Steel quantities for horizontal lap splices shall be added for wall segments greater than 30 feet, and add a splice for each additional wall segment greater than 30 feet. Horizontal 1'-0 lap splices occur at construction or contraction joints.

Steel and concrete quantities for footing steps shall be added to those shown in the table.

NOTES:

For General Notes, Typical Elevations, Sections and Details see SD 7.01 (1, 2, and 3).

For Structural Excavation Limits and Structure Backfill Limits, see SD 7.01 (4 of 5).

Note to Designer: The information presented in this Standard Drawing has been prepared in accordance with recognized engineering principles and is for general use. It should not be used for specific application without competent professional examination and verification of its suitability and applicability by a licensed professional engineer. Contents within the inner border line shall not be altered.

PRIOR DISTRIBUTION DATE 01/15

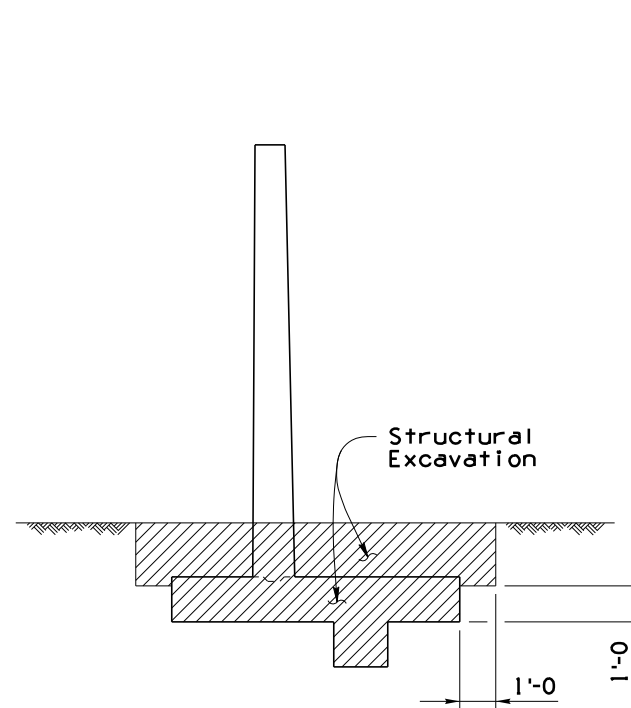

STRUCTURAL EXCAVATION LIMITS

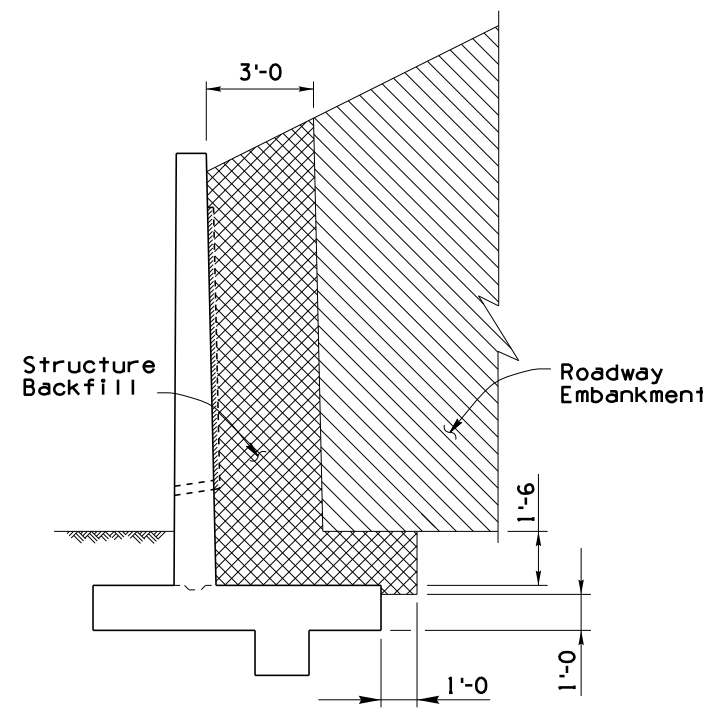

STRUCTURE BACKFILL LIMITS

STANDARDS ENGINEER <b>A. ALZUBI</b> RECOMMENDED FOR APPROVAL GROUP MANAGER	ARIZONA DEPARTMENT OF TRANSPORTATION INFRASTRUCTURE DELIVERY AND OPERATIONS DIVISION BRIDGE GROUP STANDARD DRAWING
APPROVED <b>D. EBERHART</b>	RETAINING WALL REINFORCED CONCRETE CANTILEVER
STANDARDS COMMITTEE APPROVED FOR DISTRIBUTION	DRAWING NO. <b>SD 7.01</b> (4 of 5)

12/21  
DATE

CASE IV - ADJACENT TRAFFIC BARRIER

QUANTITIES

LIMIT STATE NOTES:

Dimensions							Steel List										Service Limit State			Strength Limit State											
H	W	B	C	F	E	X	S1			S2			S3			H	V	Y			F1			F2	Qtveu-SERV Lbs./Sq.Ft.	Qnveu-SERV Lbs./Sq.Ft.	B'SERV Ft.	Qtveu-STR Lbs./Sq.Ft.	Qnveu-STR Lbs./Sq.Ft.	B'STR Ft.	
							Bar Size	Spacing	Length	Bar Size	Spacing	Length	Bar Size	Spacing	Length			Number	Length	Bar Size	Spacing	Length	Number								Bar Size
4'	5'-0	1'-0	1'-6	1'-0	2'-6	1'-0	5	12"	5'-6						4	3'-9	5	12"	4'-0	4	5	12"	3'-9	4	1970	1610	2.92	2450	1970	3.09	
5'	5'-0	1'-0	1'-6	1'-0	2'-6	1'-0	5	12"	6'-6						6	4'-9	5	12"	4'-0	4	5	12"	3'-9	4	1900	1540	3.27	2350	1860	3.49	
6'	5'-6	1'-0	1'-6	1'-0	3'-0	1'-6	5	12"	7'-6						6	5'-9	5	12"	4'-0	4	5	12"	4'-3	4	1610	1250	4.40	2030	1540	4.63	
7'	5'-6	1'-3	1'-6	1'-0	3'-0	1'-6	5	12"	8'-9						8	6'-9	5	12"	4'-0	4	5	12"	4'-3	4	1590	1200	4.91	1980	1450	5.22	
8'	6'-0	1'-3	1'-9	1'-0	3'-3	1'-8	5	12"	9'-9						10	7'-9	5	12"	4'-6	4	5	12"	4'-6	4	1520	1130	5.72	1950	1420	5.94	
9'	6'-6	1'-3	2'-0	1'-1	3'-5	1'-8	5	12"	6'-6	5	12"	10'-9			10	8'-9	5	12"	5'-0	4	5	12"	4'-9	4	1490	1100	6.50	2100	1570	6.12	
10'	7'-0	1'-3	2'-0	1'-1	3'-11	1'-10	5	12"	7'-6	5	12"	11'-9			12	9'-9	5	12"	5'-3	5	6	12"	5'-6	5	1670	1280	6.55	2370	1840	6.15	
11'	7'-6	1'-3	2'-3	1'-2	4'-1	2'-0	5	12"	8'-6	5	12"	12'-9			14	10'-9	5	12"	5'-6	5	6	12"	5'-9	5	1770	1380	6.82	2520	1990	6.38	
12'	8'-0	1'-3	2'-3	1'-2	4'-7	2'-0	6	12"	9'-6	5	12"	13'-9			14	11'-9	5	12"	6'-0	5	7	12"	6'-9	5	1950	1560	6.94	2790	2260	6.48	
13'	8'-6	1'-3	2'-6	1'-3	4'-9	2'-2	6	12"	7'-0	6	12"	10'-6	5	12"	5'-6	16	12'-9	6	12"	6'-6	5	8	12"	7'-9	5	2050	1660	7.24	2930	2410	6.74
14'	9'-0	1'-3	2'-6	1'-4	5'-2	2'-4	6	12"	8'-3	6	12"	11'-6	5	12"	5'-6	18	13'-9	6	12"	6'-9	5	9	12"	8'-6	6	2230	1840	7.41	3200	2680	6.89
15'	9'-6	1'-4	2'-9	1'-5	5'-4	2'-6	7	12"	5'-6	7	12"	12'-9	5	12"	5'-6	18	14'-9	6	12"	7'-0	5	9	12"	9'-0	6	2350	1950	7.69	3390	2850	7.13
16'	10'-0	1'-5	2'-9	1'-6	5'-9	2'-8	7	12"	5'-6	7	12"	13'-9	5	12"	5'-6	20	15'-9	6	12"	7'-6	5	8	9"	9'-0	6	2560	2150	7.85	3700	3140	7.27
17'	10'-6	1'-6	3'-0	1'-7	5'-11	2'-10	8	12"	7'-9	7	12"	15'-0	5	12"	5'-6	22	16'-9	7	12"	7'-9	6	8	8"	9'-3	7	2680	2260	8.15	3880	3310	7.52
18'	11'-0	1'-7	3'-0	1'-8	6'-4	3'-0	8	12"	8'-0	8	12"	13'-0	6	12"	9'-3	22	17'-9	7	12"	8'-6	6	8	6"	9'-6	7	2880	2450	8.40	4180	3600	7.75
19'	11'-6	1'-8	3'-3	1'-9	6'-6	3'-2	8	12"	10'-3	8	12"	13'-9	6	12"	9'-3	24	18'-9	7	12"	8'-6	6	8	6"	9'-9	7	2990	2550	8.74	4350	3760	8.04
20'	12'-0	1'-9	3'-3	1'-10	6'-11	3'-4	9	12"	10'-6	8	12"	15'-0	6	12"	9'-3	26	19'-9	7	12"	9'-0	6	8	6"	10'-3	7	3200	2750	9.01	4650	4040	8.29
21'	12'-6	1'-10	3'-6	1'-11	7'-1	3'-6	9	12"	10'-0	9	12"	16'-6	6	12"	9'-3	26	20'-9	7	9"	9'-6	6	8	6"	10'-6	8	3310	2850	9.35	4820	4200	8.58
22'	13'-0	1'-11	3'-6	2'-0	7'-6	3'-8	9	12"	11'-0	9	12"	17'-6	6	12"	9'-3	28	21'-9	7	9"	9'-9	7	9	6"	11'-6	8	3520	3050	9.62	5120	4490	8.83
23'	13'-6	2'-0	3'-9	2'-2	7'-7	3'-10	10	12"	12'-6	9	12"	19'-0	6	12"	9'-3	30	22'-9	8	12"	10'-0	7	9	6"	11'-9	8	3590	3110	9.98	5250	4600	9.14
24'	14'-0	2'-2	3'-9	2'-4	7'-11	4'-0	10	12"	13'-6	9	12"	20'-0	6	12"	9'-3	30	23'-9	8	12"	10'-6	7	9	6"	12'-0	8	3830	3330	10.21	5600	4930	9.34
25'	14'-6	2'-4	4'-0	2'-6	8'-0	4'-2	10	12"	14'-6	9	12"	21'-0	6	12"	9'-3	32	24'-9	8	12"	10'-9	7	9	6"	12'-6	9	4020	3500	10.50	5880	5170	9.58
26'	15'-0	2'-6	4'-0	2'-8	8'-4	4'-4	10	12"	14'-6	10	12"	22'-6	6	12"	9'-3	34	25'-9	8	12"	11'-0	7	10	9"	13'-3	9	4270	3730	10.74	6240	5510	9.79
27'	15'-6	2'-9	4'-3	2'-10	8'-5	4'-6	10	12"	15'-0	10	12"	23'-6	6	12"	10'-3	34	26'-9	8	12"	11'-6	8	10	9"	13'-3	9	4450	3880	11.00	6520	5750	9.99
28'	16'-0	3'-0	4'-3	3'-0	8'-9	4'-8	10	12"	15'-6	10	12"	24'-6	6	12"	11'-3	36	27'-9	8	12"	12'-0	8	10	9"	13'-6	9	4730	4130	11.20	6940	6130	10.16
29'	16'-6	3'-3	4'-6	3'-3	8'-9	4'-10	11	12"	16'-3	9	12"	25'-0	6	12"	12'-3	38	28'-9	8	12"	12'-6	8	10	9"	14'-0	9	4920	4290	11.46	7240	6380	10.36
30'	17'-0	3'-6	4'-6	3'-6	9'-0	5'-0	11	12"	17'-0	10	12"	26'-0	6	12"	12'-9	38	29'-9	8	12"	13'-0	8	10	9"	14'-3	10	5210	4550	11.66	7670	6780	10.52

CASE IV			
H	Concrete C.Y./Ln.Ft.	Steel Lbs./Ln.Ft.	Steel (Horiz. Lap) Lbs./Splice
4'	.40	32	12
5'	.44	35	14
6'	.50	37	14
7'	.58	41	15
8'	.64	44	16
9'	.71	53	16
10'	.77	62	19
11'	.85	67	20
12'	.91	79	20
13'	.99	95	22
14'	1.07	109	24
15'	1.19	119	24
16'	1.31	126	25
17'	1.43	150	28
18'	1.57	179	28
19'	1.71	190	29
20'	1.85	207	30
21'	2.00	232	31
22'	2.16	264	33
23'	2.35	289	34
24'	2.60	301	34
25'	2.86	315	36
26'	3.13	334	38
27'	3.46	345	38
28'	3.81	358	40
29'	4.21	365	41
30'	4.63	401	42

Qtveu-SERV = Total equivalent uniform vertical bearing stress to be used only for the evaluation of settlement based on the Service I Limit State as per ADOT SF-1.

Qnveu-SERV = Net equivalent uniform vertical bearing stress to be used only for the evaluation of settlement based on the Service I Limit State as per ADOT SF-1.

B'SERV = Effective footing width to be used only for the evaluation of settlement based on the Service I Limit State as per ADOT SF-1.

Qtveu-STR = Total equivalent uniform vertical bearing stress to be used only for the evaluation of bearing resistance based on the Strength I Limit State as per ADOT SF-1.

Qnveu-STR = Net equivalent uniform vertical bearing stress to be used only for the evaluation of bearing resistance based on the Strength I Limit State as per ADOT SF-1.

B'STR = Effective footing width to be used only for the evaluation of bearing resistance based on the Strength I Limit State as per ADOT SF-1.

For other applicable limit states, perform project specific-analysis using the procedures in ADOT SF-1 (Spread Footing: Bearing Resistance and Settlement).

ADOT SF-1 memorandum is found on the Bridge Group website (Geotech Services LRF Design Memorandums).

QUANTITIES NOTE:

Quantities are shown for information purposes only. The pay item is measured per square foot of wall.

Quantities are for one L.F. of wall except for horizontal steel lap splices and footing steps.

Steel quantities for horizontal lap splices shall be added for wall segments greater than 30 feet, and add a splice for each additional wall segment greater than 30 feet. Horizontal 1'-0 lap splices occur at construction or contraction joints.

Steel and concrete quantities for footing steps shall be added to those shown in the table.

NOTES:

For General Notes, Typical Elevations, Sections and Details see SD 7.01 (1 to 4).

For Structural Excavation Limits and Structure Backfill Limits, see SD 7.01 (4 of 5).

Note to Designer: The information presented in this Standard Drawing has been prepared in accordance with recognized engineering principles and is for general use. It should not be used for specific application without competent professional examination and verification of its suitability and applicability by a licensed professional engineer. Contents within the inner border line shall not be altered.

PRIOR DISTRIBUTION DATE 01/15

Case IV - Adjacent Traffic Barrier

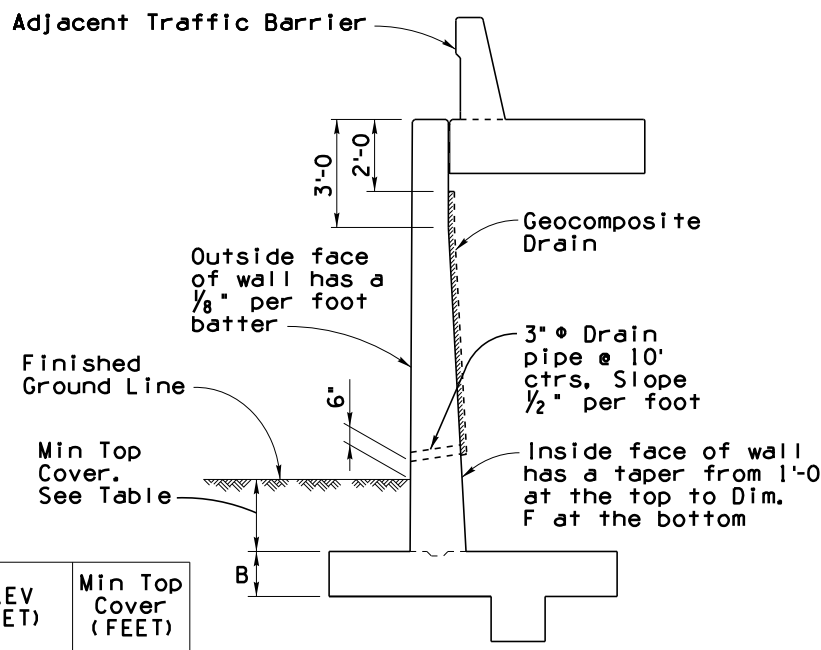

TYPICAL SECTION (Case IV)

ELEV (FEET)	Min Top Cover (FEET)
5000' and Below	1'-6
Above 5000'	2'-6

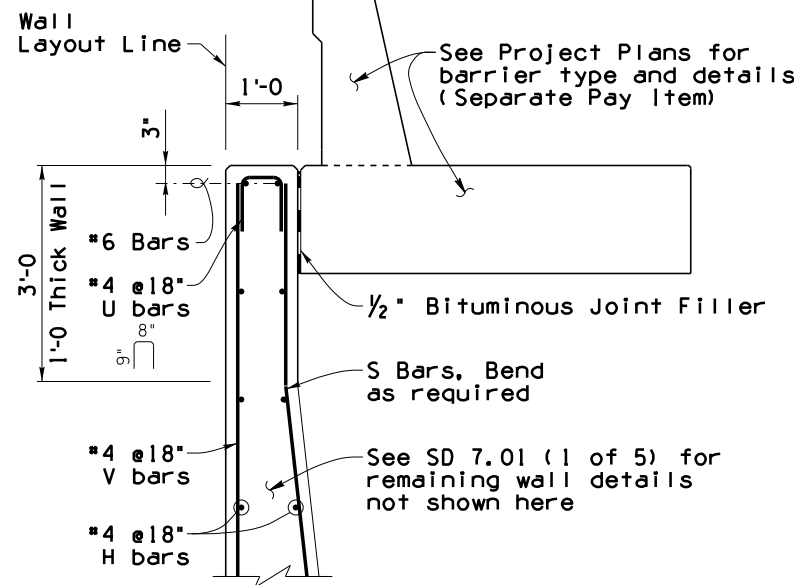

TYPICAL WALL DETAILS (Case IV)

STANDARDS ENGINEER  
**A. ALZUBI**  
RECOMMENDED FOR APPROVAL  
GROUP MANAGER

APPROVED  
**D. EBERHART**  
STANDARDS COMMITTEE APPROVED FOR DISTRIBUTION

DATE 12/21

ARIZONA DEPARTMENT OF TRANSPORTATION  
INFRASTRUCTURE DELIVERY AND OPERATIONS DIVISION  
BRIDGE GROUP STANDARD DRAWING

RETAINING WALL  
REINFORCED CONCRETE CANTILEVER

DRAWING NO.  
SD 7.01  
(5 of 5)