

Note to Designer: The information presented in this Standard Drawing has been prepared in accordance with recognized engineering principles and is for general use. It should not be used for specific application without competent professional examination and verification of its suitability and applicability by a licensed professional engineer. Contents within the inner border line shall not be altered.

PRIOR DISTRIBUTION DATE 02/23

**TABLE I NOTE:**

Welded wire reinforcement areas provided in Table I represent the largest reinforcement areas for each precast culvert span "S" and the corresponding vertical rise "R" for fill height of 2 feet to less than 10 feet.

**TABLE II NOTE:**

Welded wire reinforcement areas provided in Table II represent the largest reinforcement areas for each precast culvert span "S" and the corresponding vertical rise "R" for fill height of 10 feet to no more than 20 feet.

TABLE NO. I 2' TO LESS THAN 10' FILL HEIGHT										
Span "S"	Rise "R"	Slab "T"	Walls "W"	Haunch "H" **	Welded Wire Reinforcement Circumferential Areas Square inch / Foot					
					As1	As2	As3	As4		
6'	3'	7"	7"	7"	0.21	0.24	0.19	0.17		
	4'	7"	7"		0.19	0.27	0.21	0.17		
	5'	7"	7"		0.17	0.30	0.24	0.17		
	6'	7"	7"		0.17	0.32	0.26	0.17		
8'	3'	8"	8"	8"	0.35	0.29	0.28	0.19		
	4'	8"	8"		0.31	0.34	0.32	0.19		
	5'	8"	8"		0.28	0.37	0.35	0.19		
	6'	8"	8"		0.25	0.40	0.38	0.19		
	7'	8"	8"		0.23	0.43	0.41	0.19		
	8'	8"	8"		0.21	0.45	0.44	0.19		
10'	3'	10"	10"	10"	0.42	0.31	0.27	0.24		
	4'	10"	10"		0.38	0.35	0.30	0.24		
	5'	10"	10"		0.35	0.39	0.34	0.24		
	6'	10"	10"		0.32	0.42	0.37	0.24		
	7'	10"	10"		0.30	0.45	0.40	0.24		
	8'	10"	10"		0.27	0.47	0.43	0.24		
	9'	10"	10"		0.26	0.50	0.46	0.24		
	10'	10"	10"		0.25	0.52	0.48	0.24		
	12'	8'	12"		12"	12"	0.33	0.49	0.42	0.29
		9'	12"		12"		0.30	0.51	0.45	0.29
10'		12"	12"	0.29	0.54		0.48	0.29		
11'		12"	12"	0.29	0.56		0.51	0.29		
12'		12"	12"	0.29	0.59		0.53	0.29		

TABLE NO. II 10' TO NO MORE THAN 20' FILL HEIGHT										
Span "S"	Rise "R"	Slab "T"	Walls "W"	Haunch "H" **	Welded Wire Reinforcement Circumferential Areas Square inch / Foot					
					As1	As2	As3	As4		
6'	3'	7"	7"	7"	0.28	0.31	0.31	0.17		
	4'	7"	7"		0.24	0.34	0.35	0.17		
	5'	7"	7"		0.20	0.37	0.38	0.17		
	6'	7"	7"		0.18	0.38	0.39	0.17		
	8'	3'	8"		8"	8"	0.51	0.43	0.44	0.19
4'		8"	8"	0.44	0.48		0.49	0.19		
5'		8"	8"	0.39	0.52		0.54	0.19		
6'		8"	8"	0.36	0.55		0.57	0.19		
7'		8"	8"	0.33	0.57		0.60	0.19		
8'		8"	8"	0.31	0.59		0.62	0.19		
10'	3'	10"	10"	10"	0.68	0.48	0.49	0.24		
	4'	10"	10"		0.61	0.54	0.55	0.24		
	5'	10"	10"		0.55	0.59	0.61	0.24		
	6'	10"	10"		0.50	0.63	0.65	0.24		
	7'	10"	10"		0.46	0.67	0.69	0.24		
	8'	10"	10"		0.43	0.69	0.72	0.24		
	9'	10"	10"		0.40	0.71	0.75	0.24		
	10'	10"	10"		0.38	0.73	0.77	0.24		
	12'	8'	12"		12"	12"	0.57	0.78	0.81	0.29
		9'	12"		12"		0.53	0.81	0.85	0.29
10'		12"	12"	0.51	0.84		0.88	0.29		
11'		12"	12"	0.48	0.84		0.91	0.29		
12'		12"	12"	0.46	0.87		0.93	0.29		

\*\* In lieu of performing a special design, for the specific case where the actual haunch dimensions are larger than the standard dimensions and vertical and horizontal haunch dimensions are equal, the As1 steel area shall be increased by 1 percent for every 5 percent increase in the haunch dimension over that specified in Tables I and II.

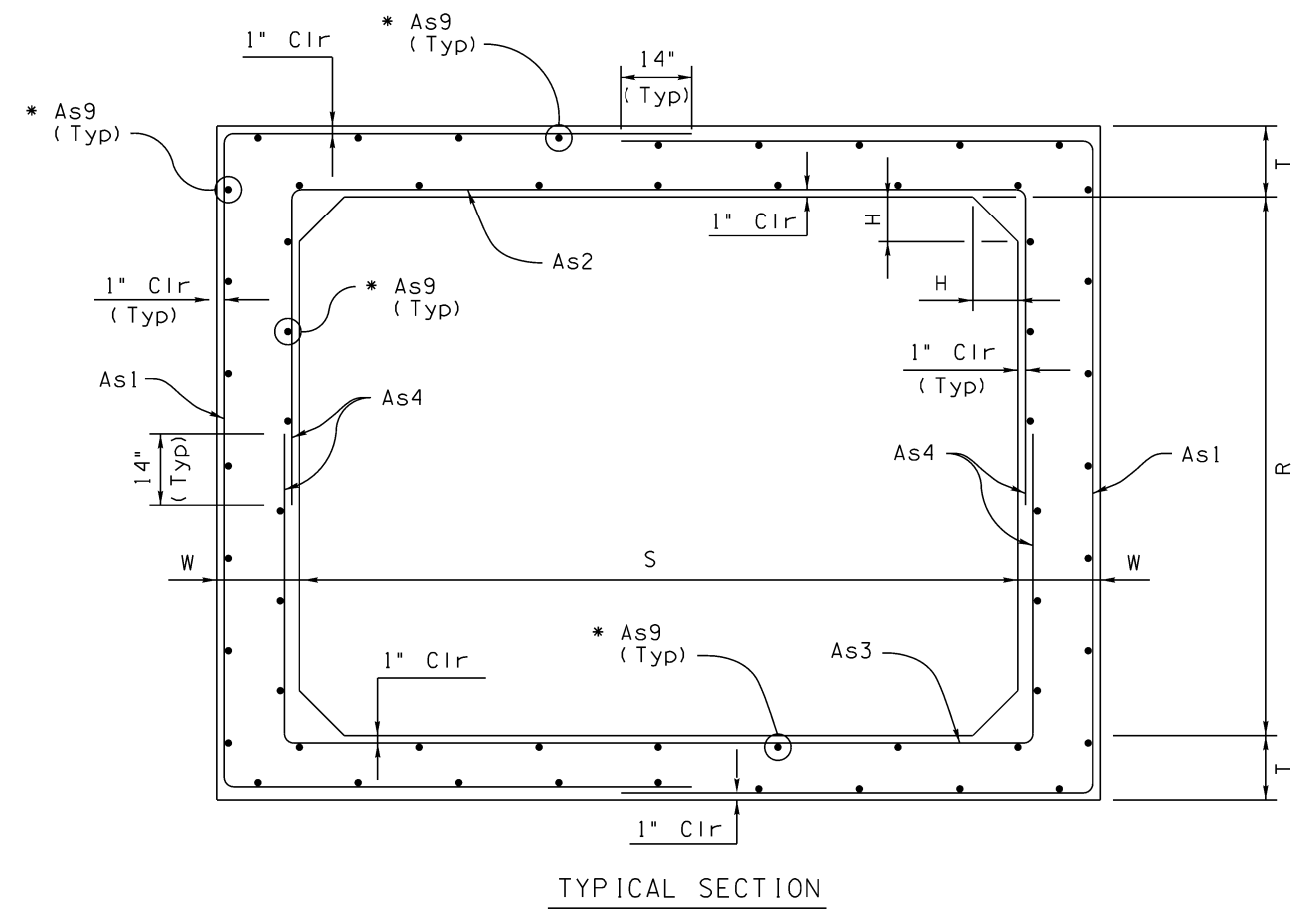

\* See General Notes for As9 spacing

**GENERAL NOTES:**

Construction Specification - Arizona Department of Transportation Standard Specifications for Road and Bridge Construction, latest Edition.

Design Specifications - AASHTO LRFD Bridge Design Specifications, 8th Edition 2017.

Precast reinforced concrete box culverts sections shown conform to ASTM C1577-20.

Sections shown in tables 1 and 2 were designed for combined earth, dead load, and HL-93 live load without Lane Load as permitted by the AASHTO LRFD Bridge Design Specifications, using either the design Truck or the design Tandem and taking the controlling case.

All Concrete shall be Class "S" (f'c = 5,000 psi).

All reinforcing steel shall consist of welded wire reinforcement conforming to ASTM A1064/A1064M (AASHTO M 336).

Circumferential reinforcement area shown in Tables I and II are based solely on the use of welded wire reinforcement with 4 inch spacing of the circumferential wires.

Longitudinal distribution reinforcement As9 is based on a D4.0 welded wire reinforcement with a 8" center to center spacing, and a minimum cross-sectional area of 0.06 in<sup>2</sup>/ft.

All circumferential reinforcing steel shall have a 1 inch clear cover unless noted otherwise.

Compact backfill for footing and wall base minimum 100 percent of ASTM D698 maximum dry density.

See Project Plans for wall layout, top of footing and finished grade elevations, footing step and wall joint locations. Construction Joints shall match the locations of weakened plane joints.

Shop Drawings shall be provided for Precast box culverts showing dimensions and details of each box section type, joint ends, seals, lifting devices, full layout plan, box section numbering, and placement sequence.

See Special Provisions for additional requirements for leveling course material, installation, structural excavation and structure backfill.

Pay item measure of linear foot of precast concrete culvert shall be along the central axis of the culvert per barrel, and shall include the length of joints and connections.

Dimensions shall not be scaled from drawings.

STANDARDS ENGINEER B. SINGH	ARIZONA DEPARTMENT OF TRANSPORTATION INFRASTRUCTURE DELIVERY AND OPERATIONS DIVISION <b>BRIDGE GROUP STANDARD DRAWING</b>	
RECOMMENDED FOR APPROVAL GROUP MANAGER D. BENTON	PRECAST REINFORCED CONCRETE BOX CULVERTS	DRAWING NO. SD 6.20
APPROVED	SINGLE BARREL NOTES & DIMENSIONS	(1 of 5)
STANDARDS COMMITTEE APPROVED FOR DISTRIBUTION	10/24 DATE	

Note to Designer: The information presented in this Standard Drawing has been prepared in accordance with recognized engineering principles and is for general use. It should not be used for specific application without competent professional examination and verification of its suitability and applicability by a licensed professional engineer. Contents within the inner border line shall not be altered.

PRIOR DISTRIBUTION DATE 02/23

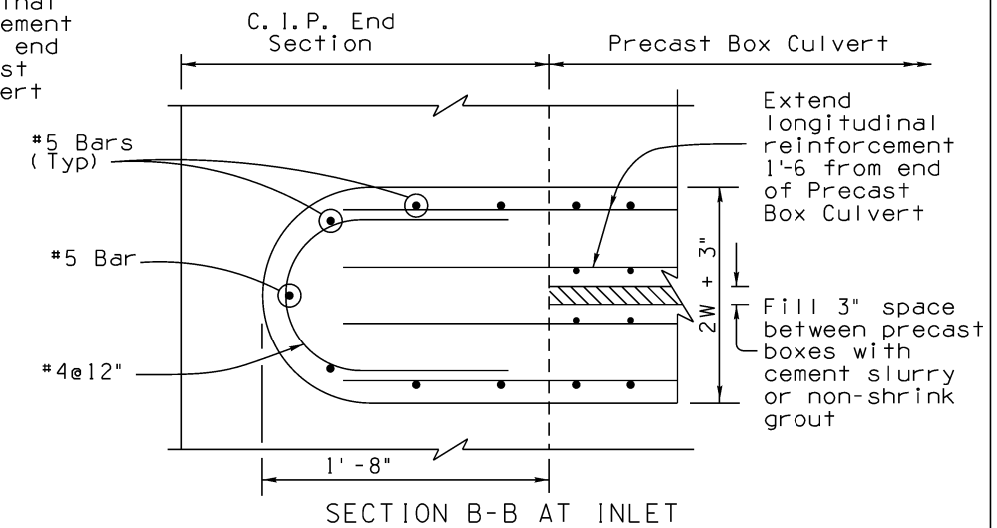
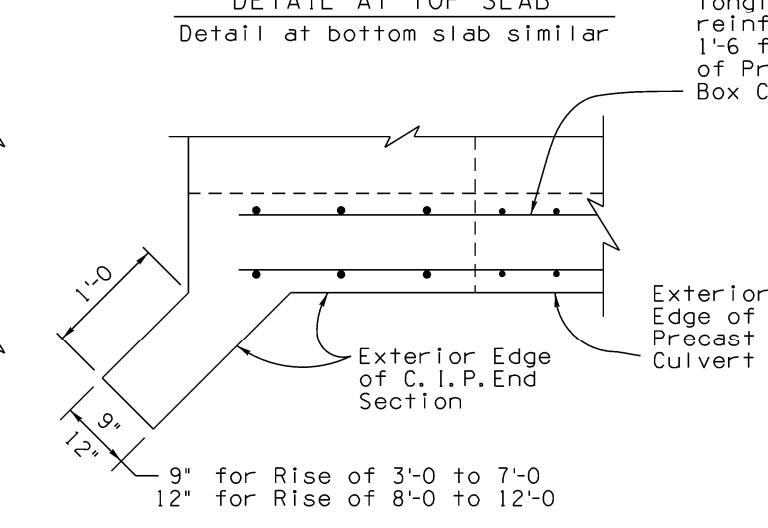
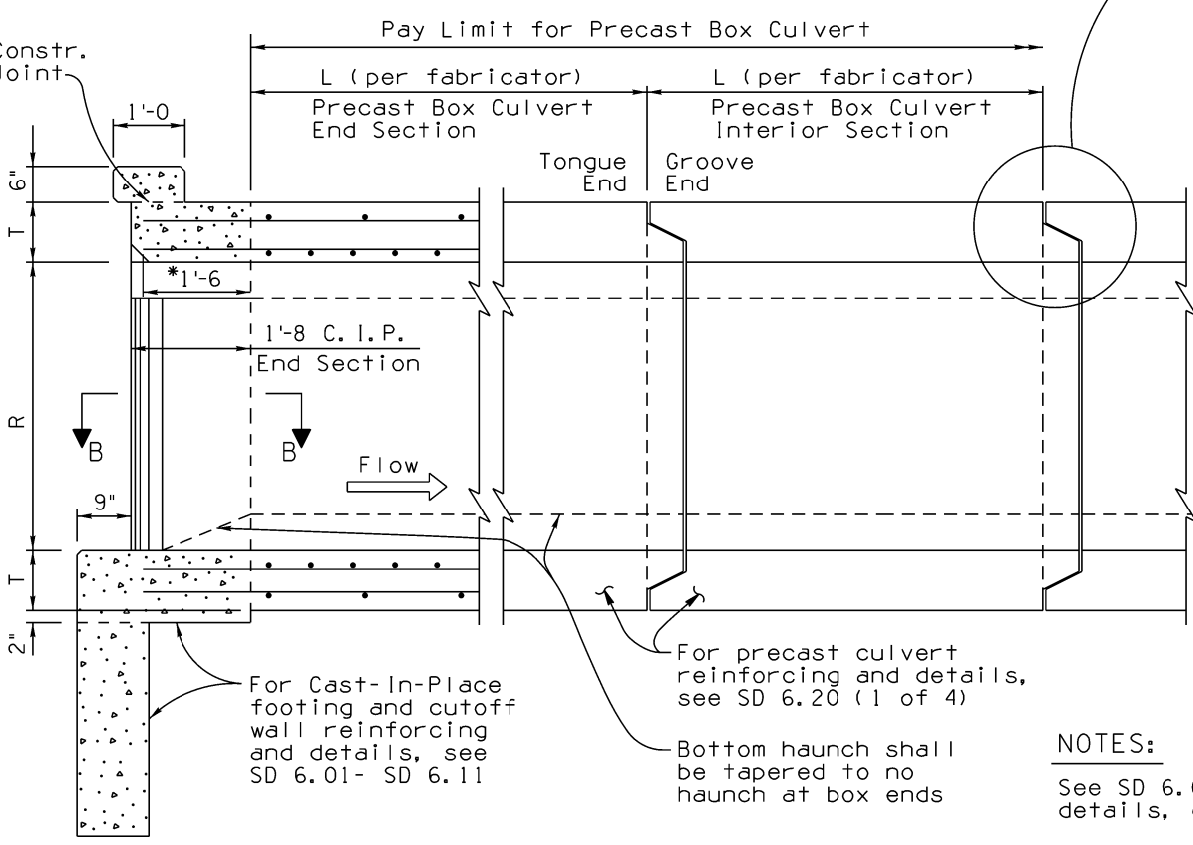
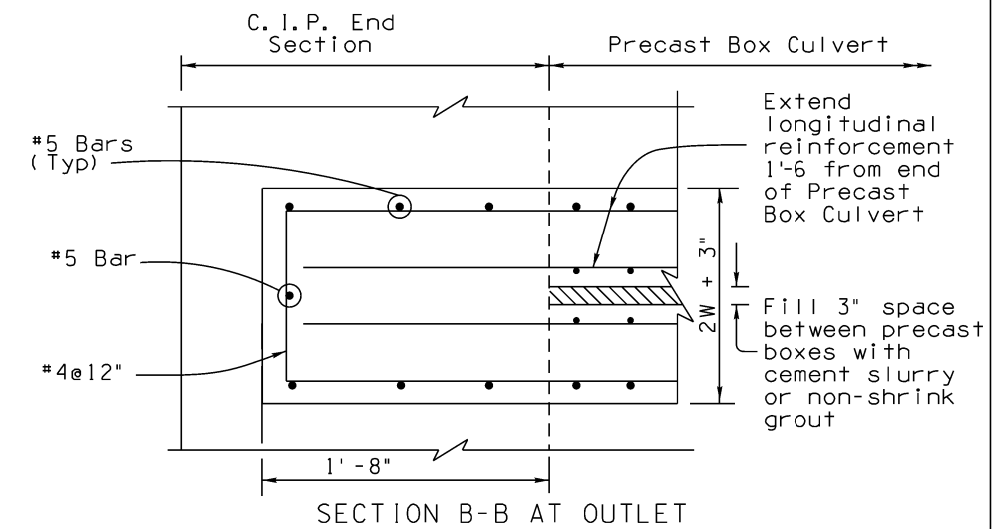
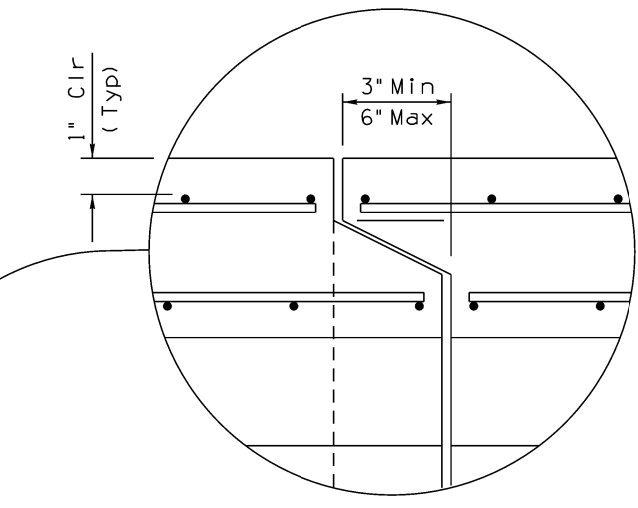
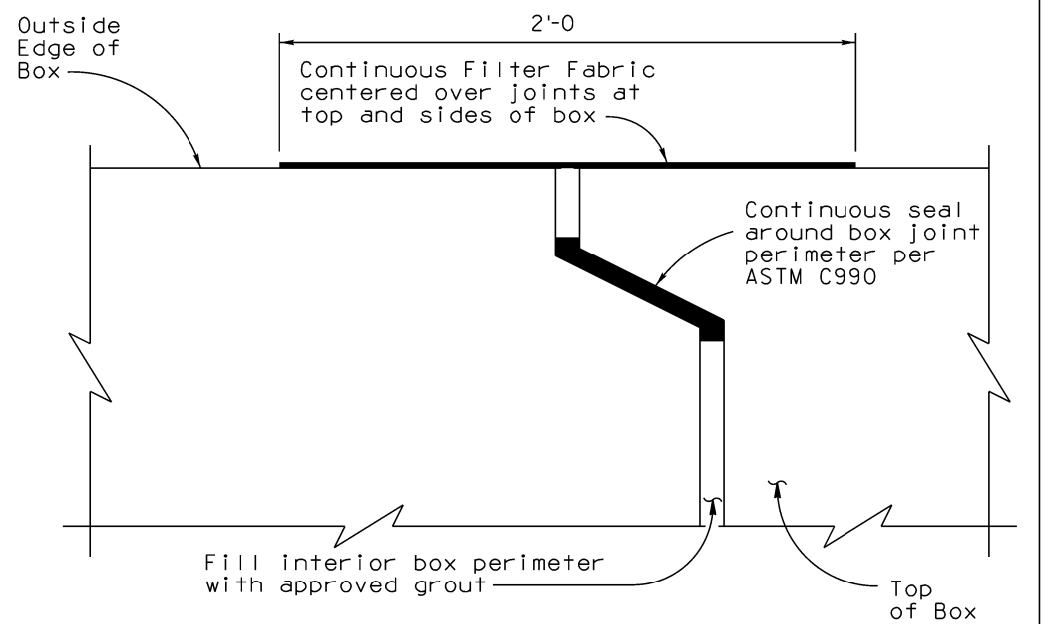
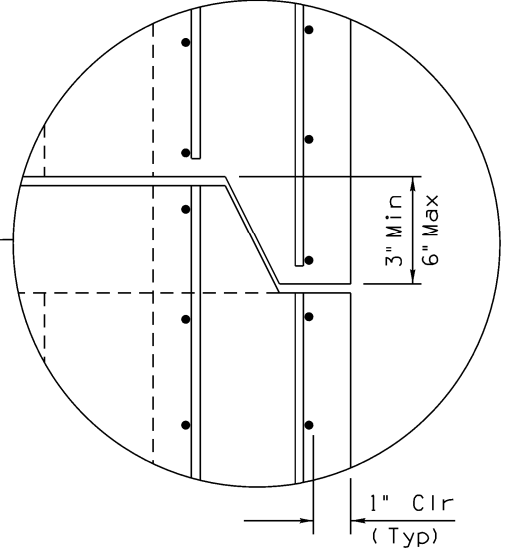
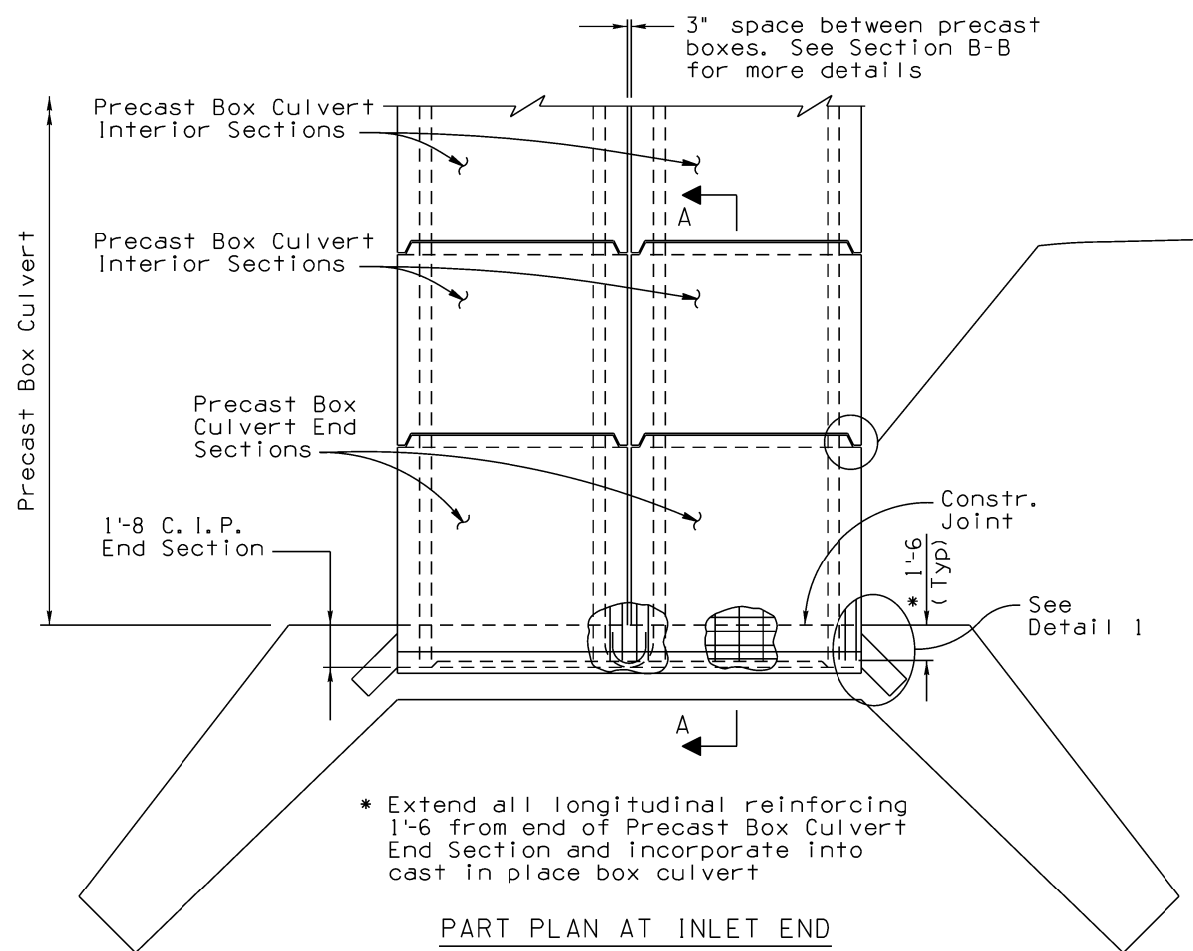

**NOTES:**

See SD 6.01-SD 6.11 for additional notes, details, dimensions, and quantities.

Footing for C.I.P. end section shall be continuous with no joints.

STANDARDS ENGINEER	B. SINGH
RECOMMENDED FOR APPROVAL	
GROUP MANAGER	D. BENTON
APPROVED	
STANDARDS COMMITTEE APPROVED FOR DISTRIBUTION	10/24 DATE

ARIZONA DEPARTMENT OF TRANSPORTATION INFRASTRUCTURE DELIVERY AND OPERATIONS DIVISION <b>BRIDGE GROUP STANDARD DRAWING</b>	
PRECAST REINFORCED CONCRETE BOX CULVERTS MISCELLANEOUS DETAILS 1	DRAWING NO. SD 6.20 (2 of 5)

Note to Designer: The information presented in this Standard Drawing has been prepared in accordance with recognized engineering principles and is for general use. It should not be used for specific application without competent professional examination and verification of its suitability and applicability by a licensed professional engineer. Contents within the inner border line shall not be altered.

PRIOR DISTRIBUTION DATE 02/23

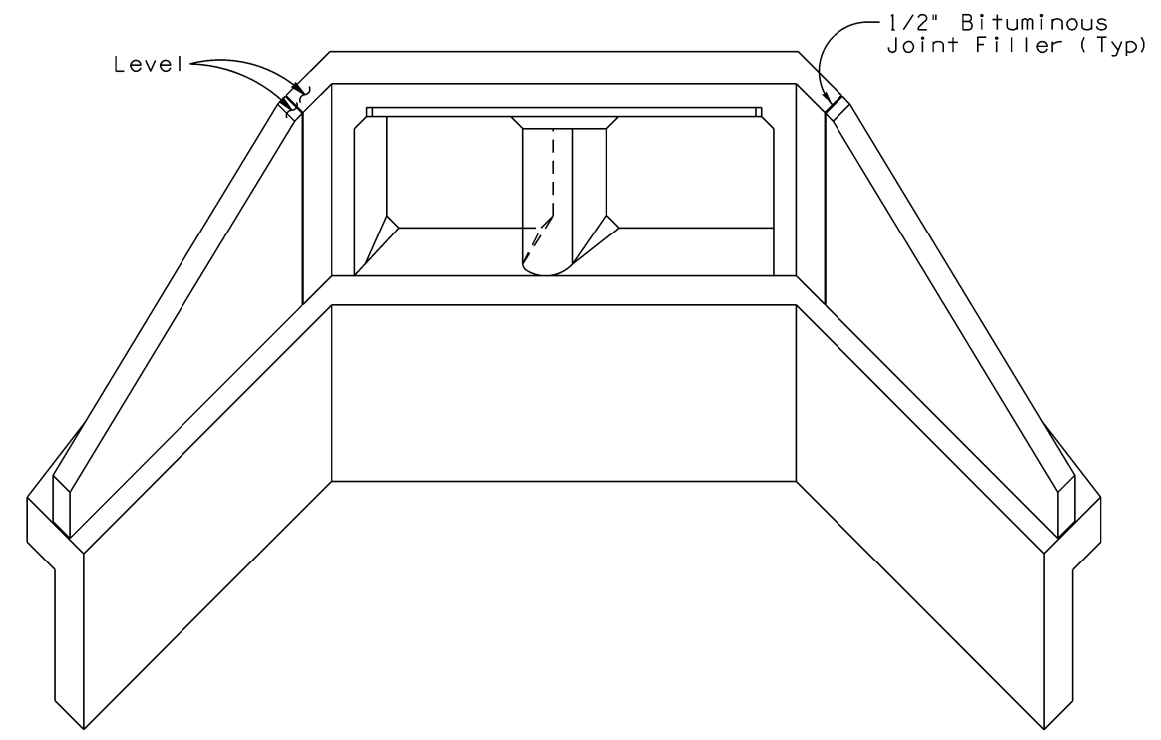

**3D VIEW OF CAST-IN-PLACE END SECTION**  
 (Double barrel culvert shown. Single or multiple barrels similar)

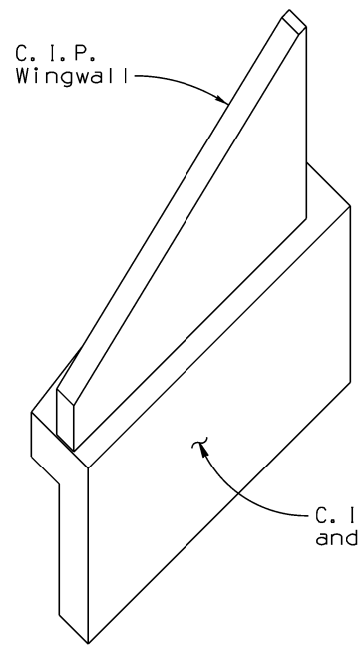

C. I. P. Wingwall  
 C. I. P. Footing and Cutoff Wall

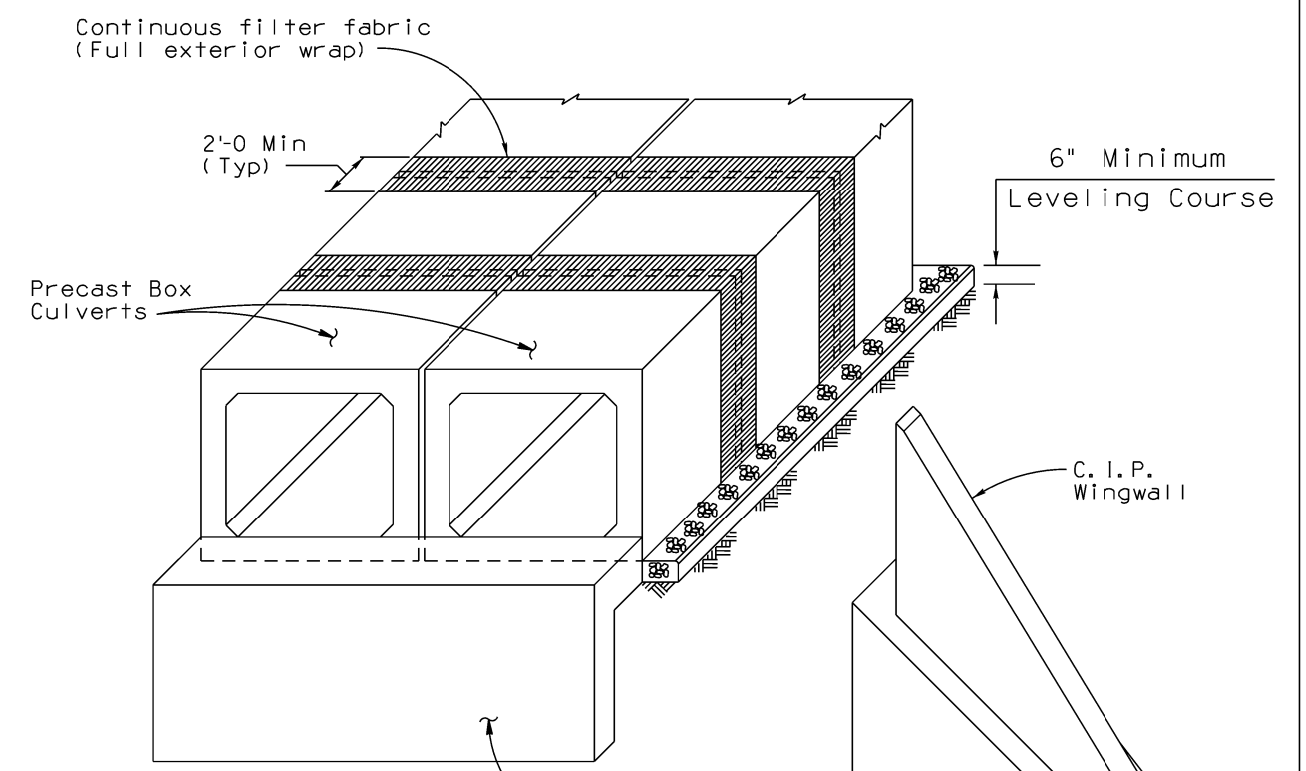

C. I. P. Footing and Cutoff Wall  
 C. I. P. Wingwall

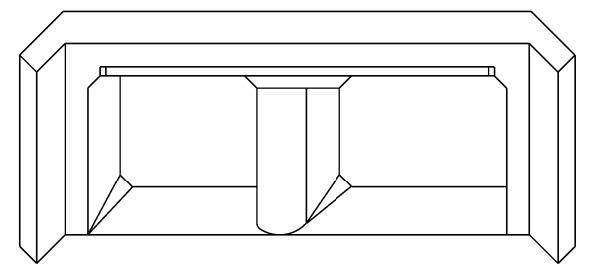

**C. I. P. END SECTION**  
 (OUTLET SHOWN, INLET SIMILAR)

**VIEW OF CONNECTIONS AT END OF CULVERT**

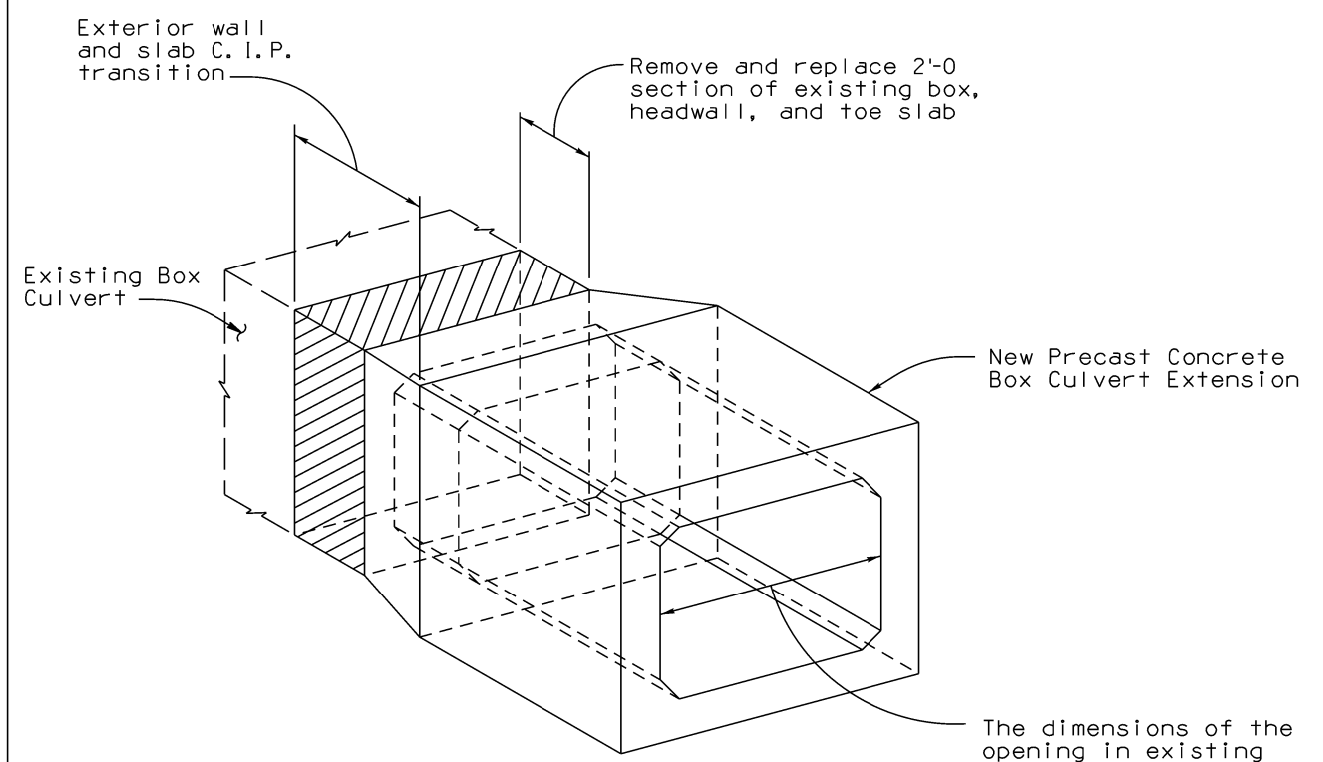

**PICTORIAL VIEW OF EXTERIOR WALL AND SLAB TRANSITION**

The dimensions of the opening in existing and new culverts are equal

STANDARDS ENGINEER	B. SINGH
RECOMMENDED FOR APPROVAL	GROUP MANAGER
APPROVED	D. BENTON
STANDARDS COMMITTEE APPROVED FOR DISTRIBUTION	10/24 DATE

ARIZONA DEPARTMENT OF TRANSPORTATION INFRASTRUCTURE DELIVERY AND OPERATIONS DIVISION <b>BRIDGE GROUP STANDARD DRAWING</b>	
PRECAST REINFORCED CONCRETE BOX CULVERTS END SECTION & CONNECTION DETAILS	DRAWING NO. SD 6.20 (3 of 5)

Note to Designer: The information presented in this Standard Drawing has been prepared in accordance with recognized engineering principles and is for general use. It should not be used for specific application without competent professional examination and verification of its suitability and applicability by a licensed professional engineer. Contents within the inner border line shall not be altered.

02/23

PRIOR DISTRIBUTION DATE

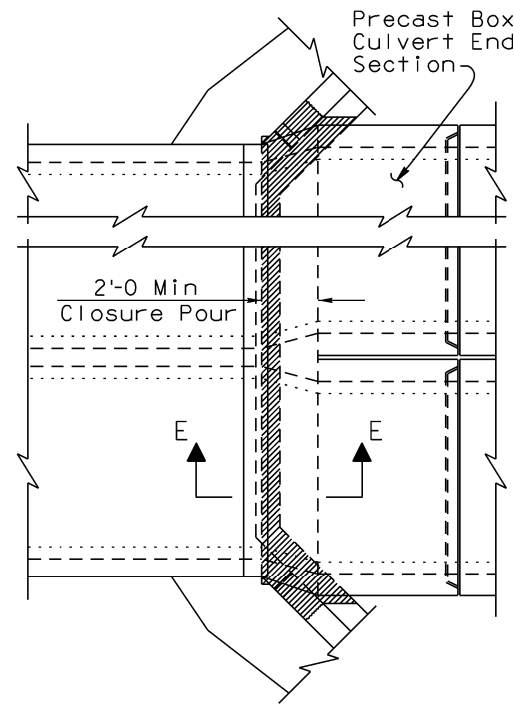

**PART PLAN CULVERT EXTENSION**  
(Showing Right Angle Culvert)

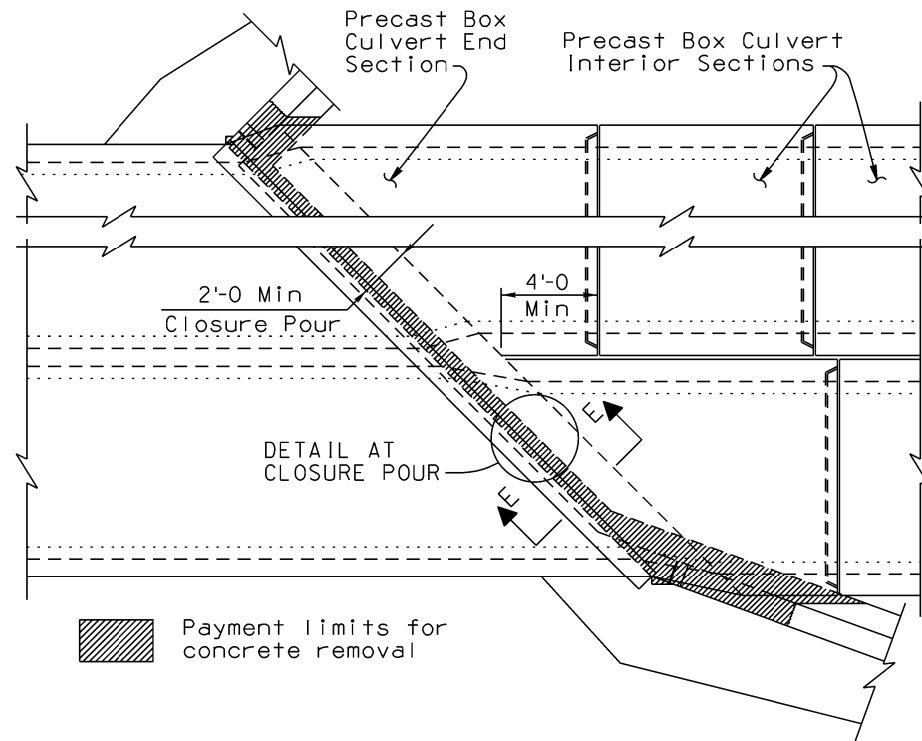

**PART PLAN CULVERT EXTENSION**  
(Showing Skewed Culvert)

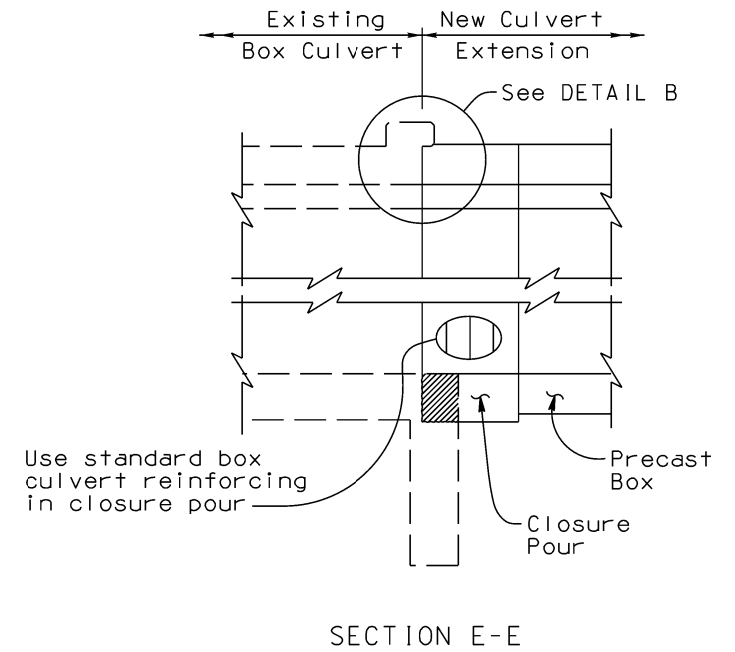

**SECTION E-E**

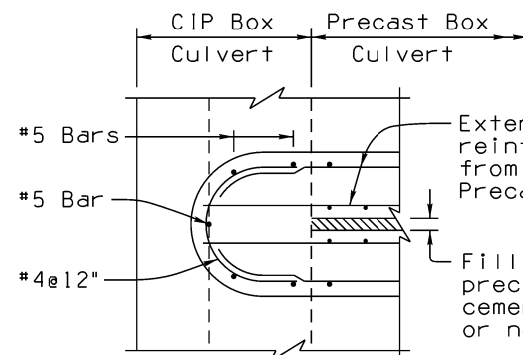

**SECTION B-B**

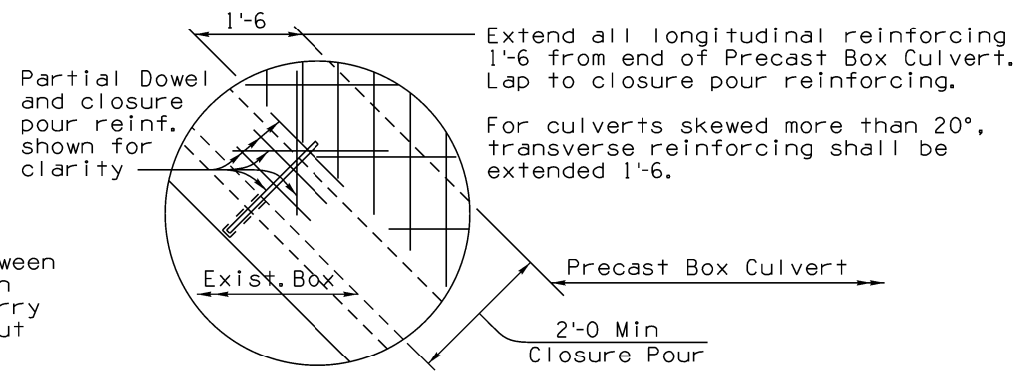

**DETAIL AT CLOSURE POUR**  
(Culvert Extension)

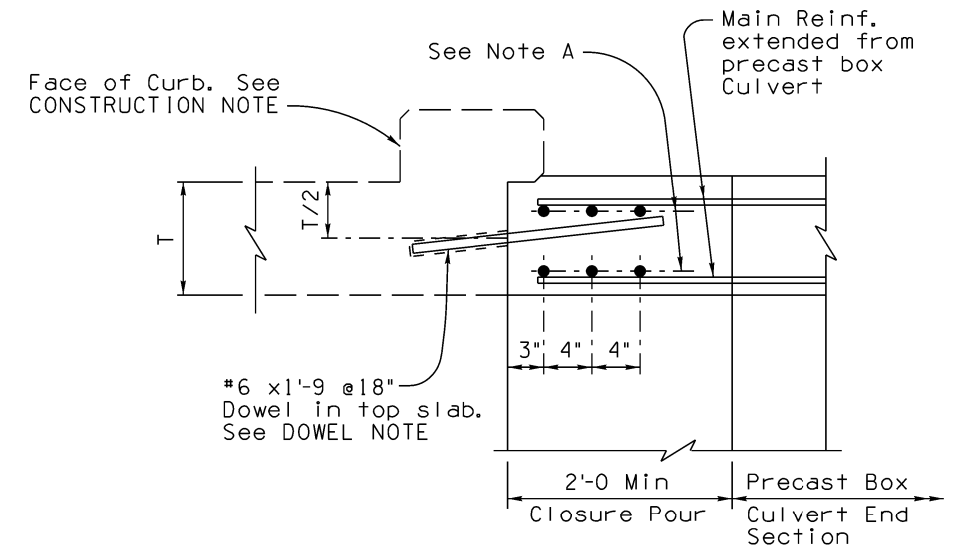

**DETAIL B**

**NOTES:**

For General Notes, Dimensions, Quantities and additional details, see SD 6.20 (1 of 4).

For Structure Backfill Details, see SD 6.01 (4 of 5).

**DOWEL NOTE:**

Drill 1"  $\phi$  hole, 8" deep, for #6 dowel. Epoxy dowel in hole with an approved epoxy adhesive. Epoxy anchorage shall develop a tensile pullout strength of 13 kips. Details of the Anchorage System shall be submitted to the Engineer for approval prior to installation.

**CONSTRUCTION NOTE:**

Remove existing headwall as required for new construction. The Curb to remain unless within 1'-0 of finish grade. If concrete headwall is removed to face of curb, use projecting reinforcing steel for bond in new concrete (no dowels are needed). Wingwalls shall be removed a minimum of 1'-6 to provide steel for bond. Any use of mechanical couplers shall meet the requirements of the standard specifications, the approved products list, and shall be submitted to the Engineer for approval.

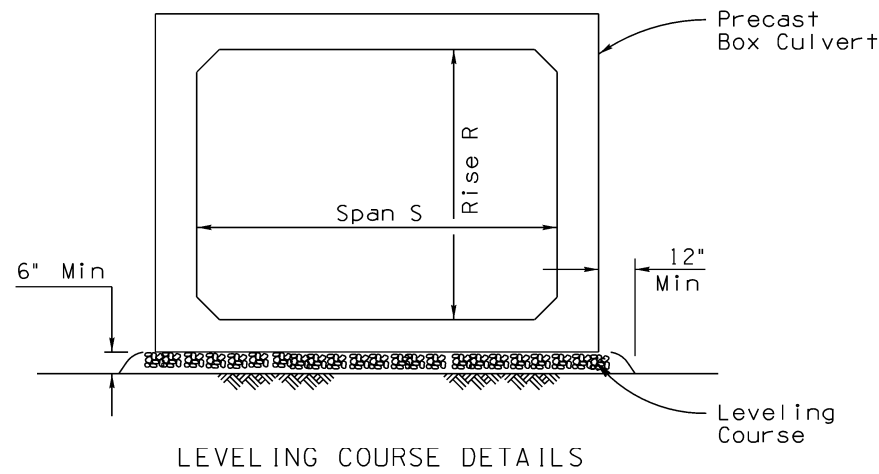

**LEVELING COURSE DETAILS**

**NOTE A:**

Use 3-#7 @ 4" spacing top and bottom bars for culverts skewed 6° to 30°.  
 Use 3-#8 @ 4" spacing top and bottom bars for culverts skewed 31° to 45°.  
 Culverts skewed more than 45° require a special edge beam design.  
 Edge beam reinforcing quantity shall be added to the quantity table.

STANDARDS ENGINEER B. SINGH	ARIZONA DEPARTMENT OF TRANSPORTATION INFRASTRUCTURE DELIVERY AND OPERATIONS DIVISION <b>BRIDGE GROUP STANDARD DRAWING</b>	
RECOMMENDED FOR APPROVAL GROUP MANAGER D. BENTON	PRECAST REINFORCED CONCRETE BOX CULVERTS MISCELLANEOUS DETAILS 2	DRAWING NO. SD 6.20 (4 of 5)
APPROVED STANDARDS COMMITTEE APPROVED FOR DISTRIBUTION	10/24 DATE	

Note to Designer: The information presented in this Standard Drawing has been prepared in accordance with recognized engineering principles and is for general use. It should not be used for specific application without competent professional examination and verification of its suitability and applicability by a licensed professional engineer. Contents within the inner border line shall not be altered.

PRIOR DISTRIBUTION DATE 02/23

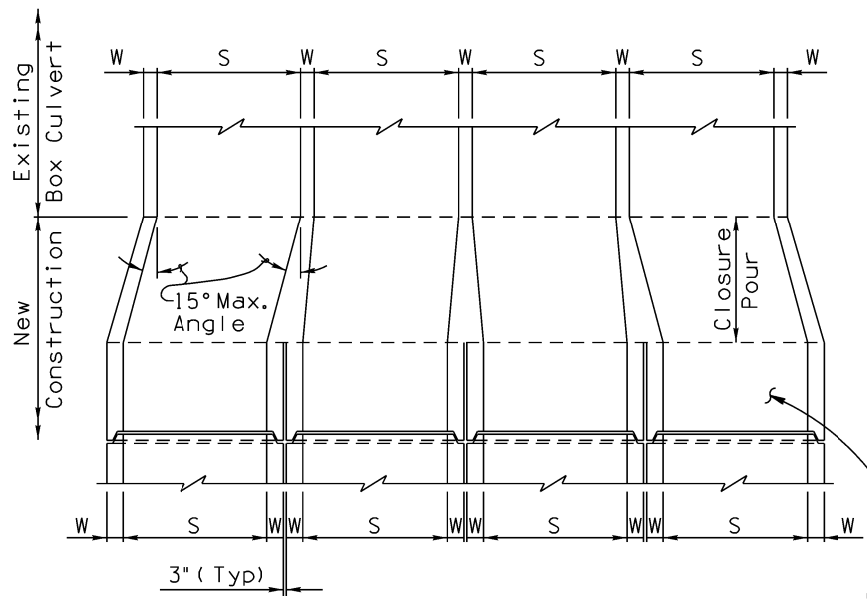

SECTION THRU CULVERT WALLS  
(Even number of cells)

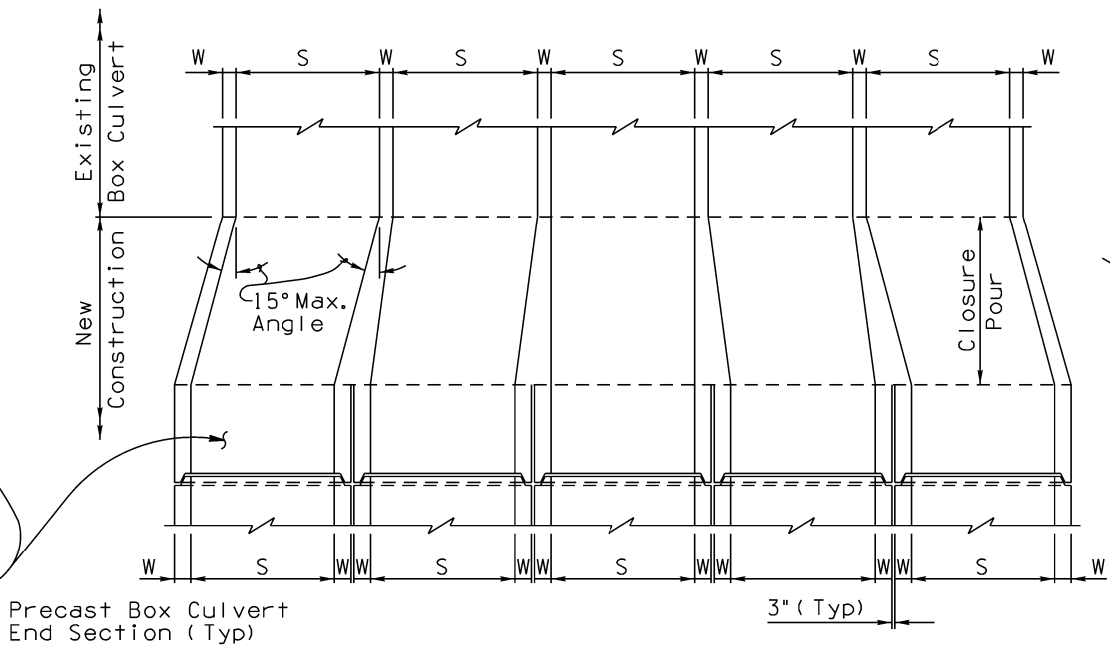

SECTION THRU CULVERT WALLS  
(Odd number of cells)

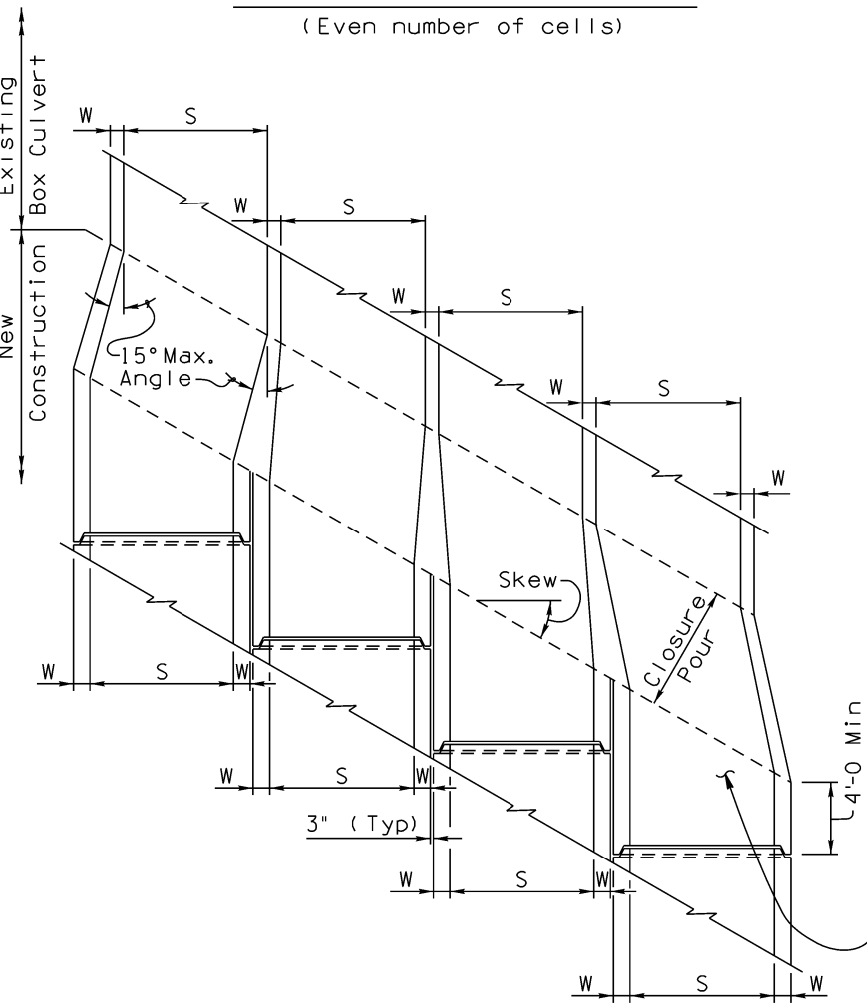

SECTION THRU CULVERT WALLS  
(Even number of cells)

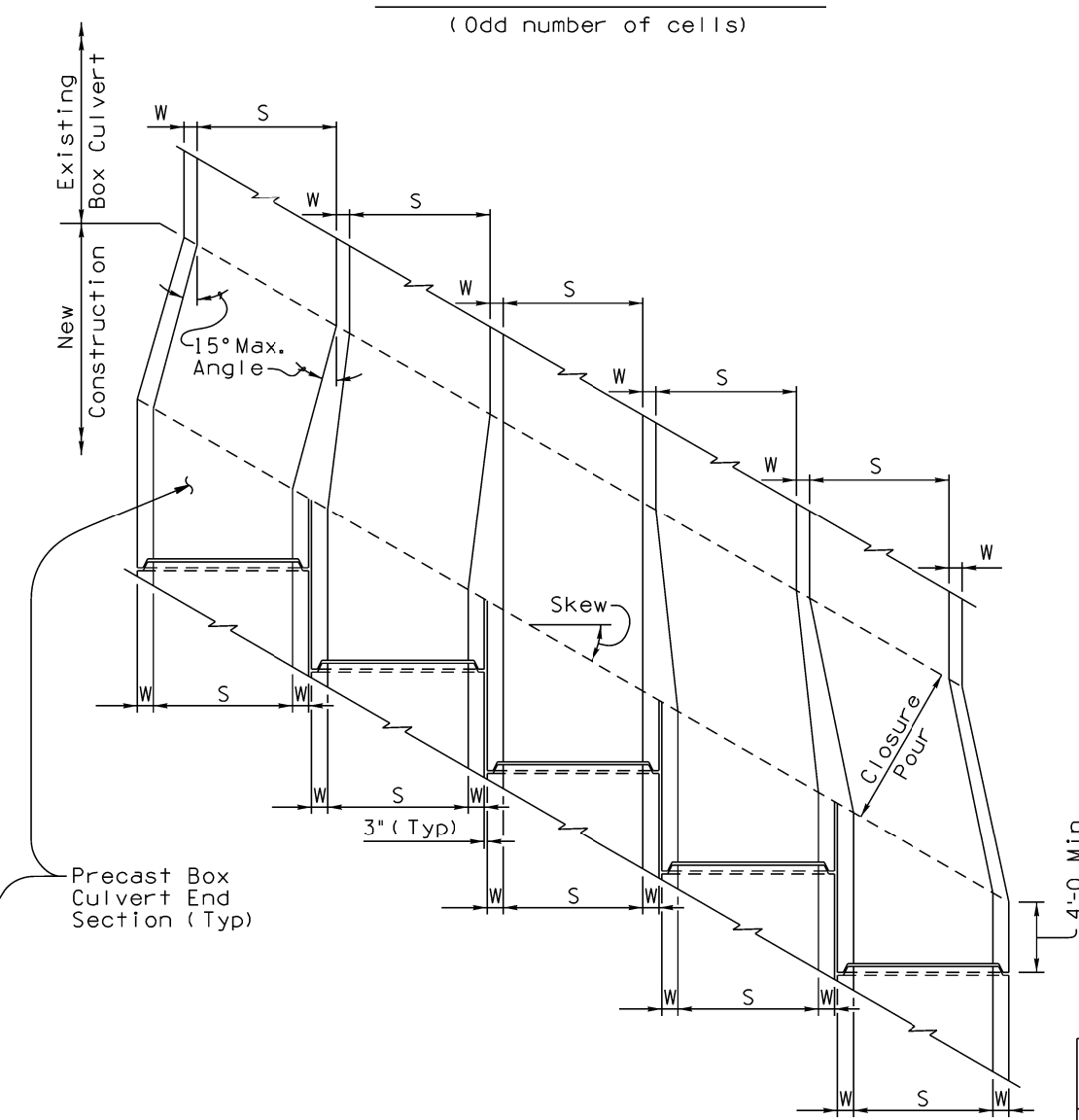

SECTION THRU CULVERT WALLS  
(Odd number of cells)

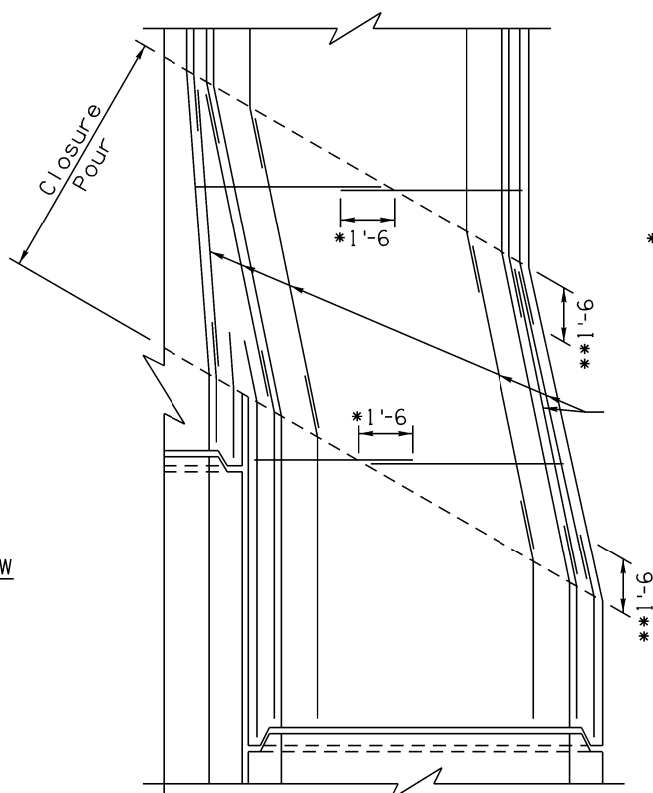

CLOSURE POUR REINFORCEMENT

For skewed ends <math>< 20^\circ</math>, Place transv. slab bars along skew.  
 \*For skewed ends  $\geq 20^\circ$ , Extend box transv. reinf. 1'-6 and lap transv. slab bars.  
 \*\*Extend box long. reinf. 1'-6, bend to wall angle.

Lap long. reinf. in walls and slabs to extended bars.

NOTE:  
Only partial reinf. shown for clarity.

For reqd. reinf. in closure pour area, See SD6.01 to SD6.06.

SPAN LENGTH	CLOSURE POUR LENGTH				
	NO. OF BARRELS				
6	2'-0	3'-9	5'-8	7'-6	9'-4
8	2'-4	4'-8	7'-0	9'-4	11'-8
10	2'-8	5'-4	8'-0	10'-7	13'-3
12	3'-0	5'-11	8'-11	11'-10	14'-10

CLOSURE POUR NOTES:

Closure pour length determined by 15° max. wall angle for exterior box offset (Min. 2'-0).

For skewed culvert ends, length of closure pour measured along  $\perp$  culvert is determined by dividing length in table by cosine of skew angle.

Culvert walls length and width varies within closure pour area to match adjoining walls. Top and bottom slab thickness may vary to match adjoining slabs.

NOTE:

For General Notes, Dimensions, Quantities and additional Details, see SD 6.20 (1 of 4).

STANDARDS ENGINEER  
 B. SINGH  
 RECOMMENDED FOR APPROVAL  
 GROUP MANAGER  
 D. BENTON  
 APPROVED  
 STANDARDS COMMITTEE APPROVED FOR DISTRIBUTION 10/24 DATE

ARIZONA DEPARTMENT OF TRANSPORTATION  
 INFRASTRUCTURE DELIVERY AND OPERATIONS DIVISION  
**BRIDGE GROUP STANDARD DRAWING**

PRECAST REINFORCED CONCRETE  
 BOX CULVERTS  
 MISCELLANEOUS DETAILS 3

DRAWING NO.  
 SD 6.20  
 (5 of 5)