

ARIZONA DEPARTMENT OF TRANSPORTATION

REPORT NUMBER: FHWA-AZ94-356-2

THE ENTERPRISE PROGRAM

EVALUATING NEW TECHNOLOGIES FOR ROADS PROGRAM INITIATIVES IN SAFETY AND EFFICIENCY

Final Report

Prepared by:
Christopher Hill
Neil Emmott
Castle Rock Consultants
18 Liberty Street, SW
Leesburg, Virginia 22075

April 1991

Prepared for:
Arizona Department of Transportation
206 South 17th Avenue
Phoenix, Arizona 85007
in cooperation with
U.S. Department of Transportation
Federal Highway Administration

Technical Report Documentation Page

1. Report No. FHWA-AZ-94-356-2		2. Government Accession No.		3. Recipient's Catalog No.	
4. Title and Subtitle ENTERPRISE Evaluating New Technologies for Roads Program Initiatives in Safety and Efficiency				5. Report Date April 1991	
				6. Performing Organization Code	
7. Author(s) Christopher Hill and Neil Emmott				8. Performing Organization Report No.	
9. Performing Organization Name and Address CASTLE ROCK CONSULTANTS 18 LIBERTY STREET SW LEESBURGH, VA 22075				10. Work Unit No.	
				11. Contract or Grant No.	
12. Sponsoring Agency Name and Address ARIZONA DEPARTMENT OF TRANSPORTATION 206 S. 17TH AVENUE PHOENIX, ARIZONA 85007				13. Type of Report & Period Covered Final Report 02/91-04/91	
				14. Sponsoring Agency Code	
15. Supplementary Notes Prepared in cooperation with the U.S. Department of Transportation, Federal Highway Administration					
16. Abstract This report defines the concept of a multi-state Intelligent Vehicle-Highway Systems (IVHS) coordination program known as the ENTERPRISE program. ENTERPRISE (Evaluating New Technologies for Roads Program Initiatives in Safety and Efficiency) is a proposal for a joint public-private sector program to research, develop and demonstrate selected IVHS technologies. This report identifies the needs, goals and objectives of ENTERPRISE and identifies why ENTERPRISE, as a consortium of interests, offers improved opportunities for IVHS research, development, testing and implementation. The report identifies likely project participants and summarizes the potential roles of both the public and the private sector. Through a worldwide review of the state-of-the-art IVHS initiatives and an inventory of proposed member initiatives, the report outlines specific projects which could be undertaken by the consortium. Finally, the report presents a proposed organizational structure of ENTERPRISE and identifies potential funding needs and resources.					
17. Key Words IVHS, ATMS, ATIS, AVCS, FMCS, ENTERPRISE, MIDAS			18. Distribution Statement Document is available to the U.S. public through the National Technical Information Service, Springfield, Virginia 22162		23. Registrant's Seal
19. Security Classification Unclassified		20. Security Classification Unclassified		21. No. of Pages	22. Price

LIST OF ACRONYMS

AA	U.K. Automobile Association
ABS	Antilock Braking System
ADOT	Arizona Department of Transportation
AHAR	Automatic Highway Advisory Radio
AHC	Automatic Headway Control
AHS	Automated Highway System
AIT	Alliance Internationale de Tourisme
ALI	Autofahrer Leit und Informationssystem
AMTICS	Advanced Mobile Traffic Information and Communication System
ARCS	Automatic Route Control System
ARI	Autofahrer Rundfunk Information
ARIAM	ARI aufgrund Aktueller Messdaten (translated as ARI with Actual Measurement)
ASC	Automatic Steering Control
ATIS	Advanced Traveler Information Systems
ATMS	Advanced Traffic Management Systems
ATSAC	Automatic Traffic Signal and Control
ATT	Advanced Transport Telematics
AVC	Automatic Vehicle Classification
AVCCS	Advanced Vehicle Command and Control System
AVCS	Advanced Vehicle Control Systems
AVI	Automatic Vehicle Identification
AVL	Automatic Vehicle Location
AVM	Automatic Vehicle Monitoring

CACS	Comprehensive Automobile Traffic Control System
Caltrans	California Department of Transportation
CCRTA	Cape Cod Regional Transit Authority
CCTV	Closed Circuit Television
CDOH	Colorado Department of Highways
CD-ROM	Compact Disk Read-Only Memory
CIS	Communication and Information System
CRC	Castle Rock Consultants
CTS	University of Minnesota's Center for Transportation Studies
DR	Dead Reckoning
DRIVE	Dedicated Road Infrastructure for Vehicle Safety in Europe
EBU	European Broadcasting Union
ENTERPRISE	Evaluating New Technologies for Roads Program Initiatives in Safety and Efficiency
ERGS	Electronic Route Guidance System
ERIC	European Road Information Center
ETC	Electronic Traction Control
EVA	Electronic Traffic Pilot for Motorists
FCC	Federal Communications Commission
FHWA	Federal Highway Administration
FMCS	Fleet Management and Control Systems

GALACTIC	Global Liaison and Coordination in Traffic Information and Control
GPS	Navstar Global Positioning System
GRID	Golden River Incident Detection
HAR	Highway Advisory Radio
HDA	Highway Driver's Assistant
HELP	Heavy Vehicle Electronic License Plate Program
HIDO	Highway Industry Development Organization
HOV	High Occupancy Vehicle
IADOT	Iowa Department of Transportation
INFORM	Information for Motorists
IRTE	Integrated Road Transport Environment
ITS	University of California's Institute of Transportation Studies
IVSAWS	In-Vehicle Safety, Advisory and Warning System
IVHS	Intelligent Vehicle-Highway Systems
IVHS America	Intelligent Vehicle-Highway Society of America
MIDAS	Motorist Information and Driver Automation Systems
MIS	Management Information System
MITI	Japanese Ministry of International Trade and Industry
Mn/DOT	Minnesota Department of Transportation
MOC	Japanese Ministry of Construction
MOVA	Modernized Optimized Vehicle Actuation
MPT	Japanese Ministry of Posts and Telecommunications

NCHRP	National Cooperative Highway Research Program
NCTRP	National Cooperative Transit Research Program
NMCS-2	National Motorway Communications System
NODS	Near Obstacle Detection System
NYSDOT	New York State Department of Transportation
OC Transpo	Ottawa-Carleton Regional Transit Commission
PACE	Plessey Adaptive Compass Equipment
PATH	Program on Advanced Technology for the Highway
PPD	Platoon Progression Diagram
PROMETHEUS	Program for European Traffic with Highest Efficiency and Unprecedented Safety
PWRI	Public Works Research Institute
RACS	Road-Automobile Communication System
RDS	Radio Data System
RDSS	Radio Determination Satellite Services
RF	Radio Frequency
SAW	Surface Acoustic Wave
SCOOT	Split, Cycle and Offset Optimization Technique
SHRP	Strategic Highway Research Program
SLG	Synchronous Longitudinal Guidance
SSVS	Super Smart Vehicle System

TBC	Time-Based Coordination
TDC	Transport Development Centre, Transport Canada
TIME	Traffic Information and Management Equipment
TIS	Travelers' Information Stations
TMC	Traffic Message Channel
TMS	Traffic Management System
TRANSCOM	Transportation Operations Coordinating Committee
TRANSYT	Traffic Network Study Tool
TRRL	Transport and Road Research Laboratory
TTC	Toronto Transit Commission
UTC	Urban Traffic Control
UTCS	Urban Traffic Control System
VICS	Vehicle Information Communication Systems
VSC	Variable Speed Control
VTIP	Visual Traffic Information Project
VTS	Vehicle Tracking System
WIM	Weigh-In-Motion

1. OVERVIEW

1.1 Introduction

This report defines the concept of a multi-state Intelligent Vehicle-Highway Systems (IVHS) coordination program to be known as the ENTERPRISE program. ENTERPRISE (Evaluating New Technologies for Roads Program Initiatives in Safety and Efficiency) is a proposal for a joint public-private sector program to develop and demonstrate selected IVHS technologies. The program will involve government and industry participants from a number of federal and state or provincial agencies in the U.S. and Canada.

This concept definition report has been prepared by Castle Rock Consultants (CRC) under contract to the Arizona Department of Transportation (ADOT). It is the second in a series of reports investigating opportunities for the advancement of IVHS technologies. The report covers the establishment of a coordinated IVHS research and development program involving both interstate and international cooperation.

The preparation of this report has built significantly on work previously undertaken by CRC in earlier studies. This work led to the definition of the Arizona MIDAS (Motorist Information and Driver Automation Systems) program. MIDAS is a proposal for a state IVHS initiative, covering a three-phase effort over a ten-year period. Each of these phases is divided into a number of individual projects and activities, providing an overall coordinated approach toward the development of a state IVHS program.

Other federal, state and provincial agencies are also actively developing IVHS program proposals. An excellent example is the Minnesota GUIDESTAR program. Introduction of IVHS in Minnesota started several years ago when Minnesota Department of Transportation's (Mn/DOT) new Commissioner, Leonard Levine, declared three top priorities for Mn/DOT:

1. stable, adequate funding;
2. safety for travelers and Mn/DOT employees;
3. dealing with rapidly growing congestion in the Twin Cities of Minneapolis and St. Paul.

Congestion currently costs Twin Cities motorists \$450 million per year, and congested freeway miles are projected to triple by the year 2000.

Within the first phase of MIDAS, the initial investigation focused upon the definition of a state IVHS initiative. The first element of the work involved preparation of an initial feasibility report. This reviewed a range of advanced technologies and systems that can be used to address the problems of highway congestion, safety and environmental impacts. The results of this review were used as the basis for the development of the technology research and development elements of the MIDAS program.

One of the major inputs from state representatives during this initial Phase #1A was that individual state IVHS developments should be set within a broader cooperative framework. It is for this reason that the collaborative initiative addressed by this report is now being defined. This broader program will provide a vehicle for practical coordination between interrelated programs addressing distinct areas of IVHS. Participating members will jointly plan, develop and demonstrate IVHS innovations in areas of mutual interest. Each organization will focus on an agreed area of excellence for in-depth systems research, demonstration and evaluation.

In order to ensure that maximum benefit is gained from a coordinated IVHS initiative, it is essential that full consideration is given to a number of important issues in the program development process. This has been the objective of Project #1B of the multi-state program, the results of which are reflected in this report. Project #1B has involved a concept definition study, building upon the work presented in the initial Project #1A feasibility report. The concept definition study has further examined the required IVHS research, development and demonstration activities, in the context of interstate and international collaboration and coordination. This provides a natural starting point for the detailed planning and implementation activities to be undertaken next.

The scope of this report includes potential program participants, their roles in the multi-state IVHS initiative, and program organizational issues. Early chapters review IVHS technologies and current IVHS initiatives. An outline of the proposed ENTERPRISE program structure comprises the key part of the work. Summaries are provided of potential state and private sector roles. The MIDAS program is then developed in more detail, as an example of a state IVHS initiative within the ENTERPRISE framework.

After this introduction, Section 1.2 of this chapter presents a problem statement, outlining the need for IVHS in the highway environment. This includes a brief definition of IVHS and an examination of its four major technology areas. Section 1.3 then goes on to define the key objectives of the IVHS research study addressed by this report. This covers the goals of the ENTERPRISE program and the rationale behind the definition of a multi-state IVHS initiative. The next section of the chapter outlines the approach adopted by the study team in carrying out the IVHS program definition study.

Following this initial overview, Chapter 2 of the report outlines the approaches taken by other major IVHS initiatives worldwide, and the lessons that can be learned. Chapters 3 through 6 then review the four accepted areas of IVHS technology. Each chapter sets out to identify current developments and highlight areas with major potential for IVHS breakthroughs.

Chapter 7 contains the key elements of this report, defining the multi-state program proposal from various aspects. It sets out the benefits of coordinating individual federal, state and provincial efforts under the umbrella of the ENTERPRISE initiative. The chapter identifies potential program participants and outlines their likely contributions within the broader cooperative framework.

Chapters 8 and 9 consider a typical state-level contribution within the ENTERPRISE program in greater detail. They set out the major reasons why a

participating agency should initiate an IVHS program, and describes typical state or provincial program elements or components. Definition of potential test sites and coordination with other advanced technology initiatives are also covered.

Organizational considerations for the ENTERPRISE program are presented in Chapter 10 of the report. This chapter includes definition of the bridging project known as GALACTIC, which will coordinate the various ENTERPRISE activities. Finally, Chapter 11 presents a short summary and the overall conclusions of this concept development study report.

1.2 Problem statement

Traffic congestion is rapidly becoming one of the most serious problems affecting the U.S. highway network. Urban travel in general is increasing at a rate of four percent per year, but construction of new facilities is expected to accommodate less than one-fourth of this additional demand. Today, the 37 largest metropolitan areas in the United States are annually experiencing 1.2 billion vehicle hours of delay on freeways alone. Current predictions are for nearly a 50 percent increase in travel demand on urban freeways between the years 1984 and 2005. This would result in more than a 200 percent increase in recurring congestion and over a 400 percent increase in delay. Therefore, increased congestion and a continued loss of mobility are expected.

The projected growth in traffic is so great that traditional methods of road construction, demand management, and traffic control will not in themselves be satisfactory solutions. Only through an approach that captures the synergistic benefits of these traditional methods can we ensure traffic mobility in the future. Application of advanced technologies in areas such as motorist information and navigation systems, improved traffic control systems, and vehicle guidance and control systems has significant potential for relieving traffic congestion.

What is meant by advanced technologies in the context of easing traffic congestion? Loosely, we can group them under:

- * Intelligent vehicles, in which advanced technology units operate independently on individual vehicles; and
- * Intelligent highways, involving the installation of advanced technologies within the highway infrastructure.

In combination, these two categories form the basis of the IVHS concept. IVHS also involves a significant degree of cooperation and integration of the on-vehicle units and the highway infrastructure.

A convenient way of grouping advanced technologies is by function. Four broad categories of advanced technology can be considered as follows:

- * Advanced Traveler Information Systems (ATIS);

- * Advanced Traffic Management Systems (ATMS);
- * Advanced Vehicle Control Systems (AVCS); and
- * Fleet Management and Control Systems (FMCS).

The following paragraphs briefly describe key features of the technologies included in the ATIS, ATMS, AVCS and FMCS areas which are expanded in later chapters of this report.

Advanced Traveler Information Systems

ATIS technologies aim to provide motorists with in-vehicle information on congestion, traffic, weather, and highway conditions, and navigation, location or routing advice. ATIS will also provide pretrip information, allowing drivers to plan their journey before leaving the home or workplace.

Many technologies exist which can provide the traveler with this information. Some systems rely on a direct communications link to an external infrastructure, such as vehicle location systems based on satellites, while others utilize radio broadcast transmissions. An alternative class of system is entirely self-contained in the vehicle and uses techniques like dead reckoning to compute vehicle position.

Specific types of ATIS include pretrip electronic planning systems. With these, a traveler enters his origin and destination into a computer and a set of routing directions is produced. These directions can be based on minimum time, minimum distance or minimum cost routes. These systems also have strong potential for integration with transit information systems.

Traffic information broadcasting systems provide motorists with information on current highway conditions providing an opportunity to alter a route. Some systems, like the U.S. highway advisory radio, utilize conventional AM car radios but require the driver to retune to a specific frequency. Others use FM transmissions and self-tuning in-car decoders such as the West German ARI system and the Europe-wide Radio Data System.

In-vehicle navigation and location systems provide information through in-car displays. The most sophisticated systems, termed externally-linked route guidance, provide real-time information on traffic, road and weather conditions and provide appropriate route guidance to the motorists. These displays may show the highway network and the location of the traffic problems, allowing drivers to change routes and make more informed decisions, or may provide specific routing instructions.

Advanced Traffic Management Systems

ATMS are assumed to differ from traditional traffic control systems in two major respects. First, they are responsive to actual traffic flows and second, they

operate in real-time. At present, control strategies react to congestion on the highway after it has occurred. An ATMS will incorporate algorithms that can predict when and where congestion will occur and will act to prevent it.

ATMS will include area-wide surveillance and detection systems. These provide information from the perspective of the overall highway network. ATMS will also integrate traffic control on the various facilities in an area. This implies collaborative management between the authorities responsible for managing both the freeways and the surface streets. Finally, ATMS will include rapid response incident management techniques, including incident detection, verification, and the implementation of appropriate response plans. Together this information is collected at a traffic control center, at which point truly optimal solutions to traffic problems can be developed for entire areas or regions.

A number of technologies already exist that will potentially provide the basis for future ATMS approaches. These include traffic signal control systems, ranging in complexity from fixed-time, isolated intersection control through to fully responsive control operating over an entire network. Much could be achieved through better use of these existing techniques, while there are also opportunities for the development of new signal control approaches with greater potential. In particular, adaptive traffic control technology could be integrated with real-time traffic monitoring, short-term forecasting and electronic route guidance. This would permit simultaneous optimization of signal coordination and vehicle route choice within the urban highway network.

Advanced Vehicle Control Systems

Vehicle control is complex because of the many interactions which exist between the driver and the vehicle. The driver's key roles can be defined as:

- * to observe the outside environment, including highway geometry, vehicles and obstructions;
- * to operate the vehicle's control system;
- * to feedback observations and compensate for changing situations; and
- * to decide and select an appropriate trajectory ahead.

One way to improve drivers' ability to cope with increasingly demanding traffic conditions more efficiently and safely is using intelligent driver support systems and automatic control devices. Automatic vehicle control systems can help drivers to perform certain vehicle control functions, and may eventually relieve the driver of some or all of the control tasks. The use of such technologies is likely to result in greater safety, more consistent driver behavior and improved traffic flow characteristics.

Fundamental research into automatic vehicle control technologies has been taking place for several years. However, recent technological advances mean that the stage has now been reached where these investigations should move into a more advanced, coordinated research, development and demonstration phase, targeted on

system implementation within a defined timeframe. This reality has recently been recognized within a major study conducted for the National Cooperative highway Research Program into the potential of advanced technologies to relieve urban congestion.

At the most basic levels, AVCS can provide the driver with useful information and warnings, for example when a vehicle is traveling with insufficient headway. The next stage is to assist the driver more directly, helping to avoid potentially dangerous situations. At this level, AVCS could be used to control travel speeds and maintain adequate vehicle headways. The third level would provide for system intervention during emergencies, illustrated by collision warning AVCS approaches. The final level would completely take over the driving task on automated highway sections. Though AVCS are least developed of the IVHS technologies, their potential for relieving urban traffic congestion and improving rural safety could be very high.

Fleet Management and Control Systems

The category of FMCS incorporates a range of technologies that are used to improve the efficiency, safety and convenience of vehicle fleet operations. Many FMCS technologies are also applicable to the other IVHS categories, particularly ATIS and ATMS, in the context of their use with individual vehicles. The FMCS category examines the application of these technologies to fleet operations, including trucks and other commercial vehicles, transit vehicles, and police and emergency service vehicles.

One approach that can be used to improve fleet operations is the application of computer software for design and planning activities. Software packages have been widely used in the transit industry, for example, providing increased convenience for service users and more efficient use of operators' resources. IVHS technologies can also provide an important input to fleet management activities, by collecting various data for historical analysis or input to operations software.

FMCS can additionally be used to provide more immediate feedback on fleet vehicles to a central control point. This can include real-time information on vehicle location, condition and schedule adherence. These data can permit fleet supervisors to initiate control strategies to ensure optimum fleet performance, convenience or security. A number of communication and location technologies have been developed that can support this real-time monitoring facility, in conjunction with on-vehicle sensors and processing equipment. Similar approaches can also be used to develop fleet dispatching systems for taxicabs, package delivery firms or emergency services.

1.3 Objectives

This section defines the primary objectives of this multi-state IVHS program definition study. The principal objective of this report is to delineate the potential and scope of a multi-state, coordinated initiative in the field of

IVHS. This has involved identification of potential participants and activities in the program, together with examination of organizational issues. To achieve the broad goals of the MIDAS and ENTERPRISE development efforts, the following specific objectives have been addressed through the IVHS research study:

1. Update existing literature reviews of IVHS technologies and the major national and international IVHS programs;
2. Consider the integration of existing or proposed advanced technology programs into broader IVHS initiatives for both individual program participants and for the multi-state consortium as a whole, in the context of the ENTERPRISE program;
3. Identify suitable locations for the operational testing of the most promising IVHS technologies in particular states, and consider potential test sites for the broader coordinated program participants;
4. Define proposed organizational structures for individual state IVHS programs and for the broader ENTERPRISE initiative, combining state and local government, private sector participation and interstate/international cooperation;
5. Identify initial outlines of potential projects to be undertaken by ENTERPRISE participants, as a basis for final definition of the program prior to detailed planning and implementation activities;
6. Define the reasons why specific states provide appropriate locations for developing and demonstrating IVHS technologies, and why these programs should be integrated within the broader ENTERPRISE initiative;
7. Detail a series of IVHS activities to pursue through a typical constituent state program. These cover research, operational testing and implementation activities from the full IVHS technology arena and progress from a short-term through a long-term timeframe;
8. Prepare a preliminary analysis of the benefits to be derived from the various projects proposed for inclusion in the ENTERPRISE program; and
9. Prepare outline proposals for funding representative elements of the IVHS program, describing the estimated resources for the various activities and potential sources for obtaining these funds.

This concept definition report represents Project 1B of the ENTERPRISE program. In accordance with Arizona's desires to fast-track the program definition process, the report makes maximum possible use of existing review material with only limited updating as required to reflect the rapid pace of IVHS developments. Acknowledgement is made of other CRC research sponsors, including the National Cooperative Highway Research Program (NCHRP) and the National Cooperative Transit Research Program (NCTRP), which provided substantial funding for the original compilation of much of the work presented in the review.

1.4 Research approach

This section outlines the approach taken by Castle Rock Consultants in investigating options for a multi-state IVHS initiative. The research approach builds on the objectives defined in the previous section and identifies a set of specific tasks that were performed to accomplish the overall goals.

Literature review

This initial task brought together a review of literature covering the major IVHS technologies and programs on an international basis. In order to accomplish this major activity within the extremely tight timeframe of the project, the work relied extensively on previous state-of-the-art reviews performed by CRC. The efforts in this project were focused on reviewing the most recent IVHS advances.

Identify ENTERPRISE participants

This task involved the identification of potential coparticipants for this cooperative IVHS effort. The study team contacted personnel in various proposed member organizations, identifying specific areas of interest in IVHS, available research and testing facilities and locations, and ongoing or planned advanced technology initiatives.

Define a proposed ENTERPRISE organizational structure

In this task, the study team prepared a proposed organizational structure for the ENTERPRISE initiative. This involved consideration of the responsibilities of the various participating organizations, and the mechanism for coordination and liaison between program members. The organizational structure development included definition of the bridging project known as GALACTIC, which will achieve the required coordination of individual ENTERPRISE activities.

Define why ENTERPRISE should be implemented

This task involved the preparation of a series of statements outlining why the ENTERPRISE program is an appropriate mechanism for IVHS research, development and operational evaluation. The task considered how a coordinated multiparticipant initiative offers improved opportunities over isolated efforts for rapid technological advancement.

Outline ENTERPRISE projects and initiatives

In this task, the study team outlined a series of IVHS projects and activities for potential inclusion within the ENTERPRISE program. These were based on the specified needs and interests of the program members, with activities selected to take full advantage of the strengths and unique situations which exist among

the various participants. The task also involved consideration of the benefits that will result from each of the proposed ENTERPRISE projects.

Integration with other advanced technology programs

This task considered the integration of activities to be performed in the proposed IVHS program with other advanced technology initiatives. Potential program participants are already recognized leaders in the practical application of new and emerging technologies. Several have major projects already underway that demonstrate this expertise. This task aimed to identify the synergistic gains that can be accomplished by incorporating current efforts into the proposed program plan.

Identify operational testing locations

The study team identified a number of locations that can potentially be used to perform operational tests of IVHS technologies. Possible locations identified for IVHS operational tests include Crescent test sites; freeway management and traffic controls centers; and motor company high-speed proving grounds.

Define state-level organizational structure

The fourth task prepared a proposed organizational structure for a typical state-level IVHS program. The proposed structure was developed to reflect the management, technical direction and administrative needs of the future multi-strand IVHS initiative. Key participants who are expected to play vital roles in the proposed structure include state and local government representatives and the private sector.

Define why ENTERPRISE participants should implement an IVHS program

In this task, the research team prepared a series of clear and concise statements defining why participating agencies can provide appropriate locations for an integrated IVHS program. These statements serve to highlight the strengths, experience and expertise resident in the states which will be important in the development and demonstration of IVHS technologies. Statements were also developed which describe the benefits that participants can expect to derive from the ENTERPRISE program.

Develop typical state-level projects and activities

Based on the products of the earlier tasks, the study team developed a series of recommended IVHS projects and activities to be pursued through Arizona's MIDAS program, representing a typical state-level element of the ENTERPRISE initiative. These projects cover research, operational testing and implementation activities in the ATMS, ATIS and AVCS areas.

Identify the benefits of the proposed state-level projects

This activity builds directly on the work of the previous task. The study team defined the benefits of the projects included in the recommended IVHS program plan.

Prepare state-level funding proposal

This task developed an outline funding plan for the recommended Arizona MIDAS program. The funding plan provides estimates of resource levels required for specific projects and activities, as well as for overall program management.

Prepare final report

As the concluding activity of the Phase 1B effort, the study team has prepared this concept definition report on the work undertaken. This has further developed the initial feasibility report, expanding its conclusions and placing them within the overall context of the broader ENTERPRISE initiative.

1.5 Recommendations

In accordance with the conclusions and recommendations of the earlier feasibility report, this report recommends the establishment of a multi-state IVHS initiative for cooperative IVHS developments within a coordinated framework. The overall goal of the ENTERPRISE program will be the development and demonstration of selected IVHS technologies. This section provides a brief summary of the recommended steps required to accomplish this goal.

The key recommendation of this study is that participating state IVHS developments should be set within a cooperative program to be known as ENTERPRISE. ENTERPRISE will operate as an umbrella program, under which each participating member will address distinct projects and areas of IVHS, based on individual needs. Minnesota's GUIDESTAR and Arizona's MIDAS programs would represent specific elements of the ENTERPRISE program, while other members in the U.S. and Canada will implement comparable programs in their own areas of interest.

In order to accomplish the overall liaison and coordination functions envisioned within the ENTERPRISE initiative, a bridging project is proposed under the title of GALACTIC (Global Liaison and Coordination in Traffic Information and Control). As the name indicates, GALACTIC will address both North American and worldwide IVHS liaison activities related to the ENTERPRISE program.

These two aspects of the GALACTIC project can be summarized as follows:

- * **Inter-Galactic**, addressing international cooperation and liaison between the ENTERPRISE program and other worldwide IVHS programs. These include DRIVE and PROMETHEUS in Europe, plus VICS and SSVS in Japan.

- * **Intra-Galactic**, dealing with the needs of joint planning, development and demonstration for the constituent North American IVHS programs of the ENTERPRISE initiative.

These summary recommendations for a multi-state collaborative program are expanded in later sections of the report. Prior to this, relevant IVHS technologies of the ENTERPRISE initiative are described in technical review chapters.

2. IVHS INITIATIVES

2.1 Introduction

This chapter describes the major current programs and initiatives being undertaken throughout the world which have particular relevance to the objectives of this study. Following this introduction, the chapter is divided into three sections, covering the three geographic areas in which the majority of IVHS research has occurred. The first of these is the U.S., where IVHS activities have included both state-level programs and broader cooperative projects. The next section focuses upon European efforts within the multinational DRIVE and PROMETHEUS programs. Japanese IVHS initiatives are discussed in the final section of the chapter.

2.2 U.S. initiatives

It is generally acknowledged that the U.S. has some catching up to do in order to compete with the Europeans and Japanese in the area of IVHS. Both Europe and Japan had implemented large-scale coordinated IVHS programs before U.S. efforts were underway. However, substantial progress has been made in the U.S. in recent years toward redressing this imbalance. Several states have organized independent IVHS projects and activities, while a number of cooperative activities are also underway on a broader scale. Principal U.S. IVHS initiatives and organizations include the following:

- * Mobility 2000;
- * IVHS America;
- * SMART Corridor;
- * PATHFINDER;
- * TRAVTEK;
- * TRANSCOM;
- * GUIDESTAR;
- * PATH; and
- * HELP.

Mobility 2000 is an ad-hoc coalition of transportation professionals drawn from government, universities and industry. The group is seeking to establish an agenda for research, development and demonstration of IVHS technologies. Mobility 2000 is promoting the need for a cooperative program involving federal,

state and local government and private sector organizations, to increase mobility, improve safety, and meet the needs of international competitiveness.

The development of the Mobility 2000 effort has involved the formation of several technical committees. Four of these have investigated the broad technology areas outlined earlier in this report, ATIS, ATMS, FMCS and AVCS. A fifth technical committee has been responsible for evaluating operational benefits in each of these areas. Mobility 2000 has also considered IVHS program milestones, research and development needs, field test requirements and funding levels.

Mobility 2000 has now been adopted as the technical arm of the recently-formed **IVHS America** (Intelligent Vehicle-Highway Society of America). IVHS America was officially incorporated in the District of Columbia in August, 1990. The nonprofit, public/private scientific and educational corporation aims to advance a national program for safer, more economical, energy efficient and environmentally sound highways in the U.S. Membership of the group is open to companies, corporations, associations, government agencies and universities with an interest in IVHS. In addition to receiving technical support from Mobility 2000, IVHS America will benefit from the administrative support of the Highway Users Federation.

The **SMART Corridor** is a cooperative demonstration project currently being implemented by a number of agencies in the Los Angeles area. Participants in the study include the Federal Highway Administration, the California Department of Transportation, the California Highway Patrol, the Los Angeles County Transportation Commission, the Los Angeles Department of Transportation and the Los Angeles Police Department. The aim of the study is to integrate traffic sensors, computers and communications links on a 15-mile section of the Santa Monica Freeway and five adjacent arterials. The system will provide information on current traffic conditions that will be used to assist highway agencies in making control decisions. In addition, the system will provide up-to-date information to motorists through a variety of media.

The SMART Corridor project is funded at a level of approximately \$50 million, and began in 1989 with a conceptual design study. Full implementation of the system is scheduled for 1992. One of the major focuses of the study will be the methods by which information can be communicated to and from motorists in the corridor. A number of alternative approaches will be evaluated, including variable message signs, highway advisory radio, cellular telephone systems, teletext and videotext.

Closely related to the SMART Corridor study is the **PATHFINDER** project. This is a cooperative field experiment involving Caltrans, the FHWA and General Motors, which aims to perform an initial assessment of the feasibility and utility of a real-time in-vehicle navigation and motorist information system. The project is being performed within the SMART Corridor demonstration area.

The in-vehicle equipment selected for the Pathfinder is the Bosch TravelPilot version of the ETAK Navigator, described in Chapter 3 of this report. In addition to conventional map display facilities, the system includes a special two-way, time-multiplexed communications element. This is used to send vehicle speed and location data to a control center, and to return pertinent traffic data

to the in-vehicle unit. Areas of congestion are identified on the map display, allowing the driver to select an alternative route if necessary.

Testing of the Pathfinder system began in June 1990, using Caltrans employees to evaluate the ability of the system to avoid congested areas. In a second phase of testing, hired drivers will be used to establish time savings achieved through use of the system between various origins and destinations. A final test phase will examine the acceptability and perceived utility of the system for commercial drivers.

TRAVTEK is a cooperative project currently being undertaken in Orlando, Florida by the FHWA, General Motors, the American Automobile Association, Florida Department of Transportation and the City of Orlando. The study will demonstrate the use of prototype in-vehicle equipment for the provision of up-to-date traffic condition, routing and tourist information. TRAVTEK will cost approximately \$8 million and will involve 75 GM rental cars and 25 vehicles used by high mileage local drivers.

The test vehicles will be equipped with navigation and driver information systems linked to information centers by radio data communications. The in-vehicle video monitor will be capable of displaying maps of the Orlando area, including areas of congestion and services, text information on traffic incidents or services, and route guidance instructions using simple graphical cues. A traffic management center will be responsible for combining and transmitting traffic information received from a variety of sources. A 12-month operational demonstration of the TRAVTEK system is scheduled to begin in 1992.

An organization that will potentially be undertaking a major IVHS initiative in the near future is TRANSCOM (the Transportation Operations Coordinating Committee). This is a consortium of transportation agencies in the New York/New Jersey metropolitan area. TRANSCOM is responsible for coordinating regional traffic management through increased interagency cooperation, review of procedures and programs, formulation of mutual assistance programs and coordination of planned construction and maintenance activities.

The TRANSCOM IVHS study will seek to investigate the use of automatic vehicle identification (AVI) technology for traffic monitoring and management. AVI equipment is already being used in the New York/New Jersey area for automated toll collection on facilities operated by the Port Authority of New York and New Jersey and the Triborough Bridge and Tunnel Authority. The TRANSCOM study will therefore aim to use the same AVI technology in an integrated system with subsequent cost sharing benefits.

The first stage of the TRANSCOM study will focus on the design of an area-wide traffic management system. This will examine issues such as the required density of AVI readers, the number of equipped vehicles, and communications and software needs. Following completion of the design stage, equipment will be purchased and installed in the New York/New Jersey area. TRANSCOM will then evaluate system performance from the perspectives of traffic surveillance facilities, incident detection and response capabilities, and clarity of data. TRANSCOM will also examine the cost sharing options for the system and the market for traffic data collected by the AVI technology.

Among individual state initiatives, GUIDESTAR is perhaps the most important program currently being undertaken in the U.S. GUIDESTAR is a cooperative effort between the Minnesota Department of Transportation (Mn/DOT) and the University of Minnesota's Center for Transportation Studies (CTS), in partnership with other public and private organizations. The initiative has a high national profile and was the only IVHS program specifically referred to in the Secretary of Transportation's recent National Transportation Policy.

GUIDESTAR has been envisioned as a mechanism for coordinating current Mn/DOT and CTS advanced technology applications with a view toward future IVHS deployments. In the first year of the program, GUIDESTAR will review IVHS technologies and initiatives, resulting in the development of a six-year strategic plan for IVHS research and development. One aspect of GUIDESTAR will be a joint venture between Mn/DOT and CTS to test a video-based real-time traffic information system called Autoscope. This will use video cameras and processing equipment to measure traffic volumes, speeds and congestion levels. A \$1.4 million evaluation of Autoscope is due to start in 1991 using 20 cameras installed on Interstate 394 in Minneapolis.

PATH (Program on Advanced Technology for the Highway) is the main element of the California Department of Transportation's new technology development program. The initiative has a proposed budget of \$56 million over a six-year period, with sponsorship from Caltrans, the FHWA and the National Highway Traffic Safety Administration. PATH research is conducted primarily by the University of California's Institute of Transportation Studies (ITS) at Berkeley.

The main focus of PATH is vehicle and highway automation, with the ultimate goal of completely automated vehicle operations. A major element of the research is investigation of roadway electrification, continuing previous work undertaken in the Santa Barbara Electric Bus Program. PATH is also conducting research into longitudinal and lateral control of vehicles based on a number of alternative technical approaches. In addition, PATH is performing research on traffic management and driver information systems, including consideration of driver behavior and safety aspects.

The main U.S. initiative in the area of FMCS is HELP - the Heavy Vehicle Electronic License Plate program. HELP is a \$20 million program funded and directed by a group of 14 states, the Port Authority of New York and New Jersey, various motor carrier organizations and the FHWA. The aim of the program is to research and develop an integrated heavy vehicle management system combining AVI, weigh-in-motion and automatic vehicle classification technologies with a networked data communications system, comprising roadside stations linked to regional and central computers. Arizona is the lead state of the HELP program, providing valuable opportunities for cooperation and integration with other IVHS initiatives in the state as described in Chapter 7 of this report.

2.3 European initiatives

In Europe, a number of large-scale IVHS programs have been implemented. These are generally multinational initiatives, in contrast to some of the individual

state activities being undertaken in the U.S. Most of the European programs are organized and coordinated under the control of the Commission of the European Communities, a group of 12 member countries working toward economic unification in 1992, or as part of EUREKA, an industrial research initiative involving 19 countries. Two programs that are of particular interest in the context of this study are PROMETHEUS and DRIVE.

PROMETHEUS (Program for European Traffic with Highest Efficiency and Unprecedented Safety) is a \$700 million research program to define and develop road traffic of the future based on advanced technologies. Organized under the EUREKA umbrella, PROMETHEUS is a collaborative effort between European automobile manufacturers and their respective governments. The objective is to create concepts and solutions which will make vehicles safer and more economical, with less impact on the environment, and will render the traffic system more efficient.

The program was initiated in 1986 by the European automotive companies, to respond to increasing competition from Japan and North America in the field of information and communication technologies. In addition to strengthening European competitiveness through coordinated concepts, the program aims to produce a totally integrated highway transportation system throughout Europe. The time span for developments emerging from the program is expected to cover a period of more than twenty years.

The PROMETHEUS project combines both scientific basic research conducted by universities and research institutes, and applied research conducted by industry. This cooperation is being accomplished by the support of government agencies responsible for highway transportation and telecommunications. To ensure integration of national and European interests, a PROMETHEUS Council has been formed under the chairmanship of the Federal Ministry for Research and Technology in Germany.

PROMETHEUS has been subdivided into seven program areas. Three are being undertaken primarily by the automobile industry and the remainder primarily by research agencies and government. The industry-related areas are as follows:

- PRO-CAR: The objective of this program area is to develop systems which will assist or support the driver in performing the driving tasks. Using onboard computers, these systems will take inputs from sensors and actuators on the vehicle, interpret them and then take appropriate actions. Impending critical situations can be recognized and the systems can instigate emergency action to prevent accidents.
- PRO-ROAD: The second area of research for industry concerns the development of communication and information systems between roadside and onboard computers. This will enable drivers to receive information upon which they can individually optimize their driving patterns.
- PRO-NET: The final aspect being performed by the industrial participants concerns the development of a communication network between vehicle computers. The implementation of such a network would allow vehicles

to be operated . . . "electronic sight," enhancing the perceptive range of the driver beyond his own range of vision.

The remaining subprograms concern basic research. The four areas are outlined below:

- PRO-ART: This subprogram is examining and developing the principles of systems which use artificial intelligence. Methodological investigations and studies of problem areas and experimental systems are included in this research.
- PRO-CHIP: The aim of this area is primarily the development of microelectronics required for artificial intelligence systems, of a size and reliability for incorporating within vehicles. Other microelectronics required by PROMETHEUS are also being addressed in this subprogram.
- PRO-COM: The field of communication is being considered in PRO-COM. Architecture and general protocols are being developed to optimize data communication between vehicles, road and environment.
- PRO-GEN: The final subprogram of PROMETHEUS is aiming to develop scenarios in the area of traffic engineering, which adapt the road system to the technical developments.

DRIVE (Dedicated Road Infrastructure for Vehicle Safety in Europe) is a program coordinated by the Commission of the European Communities. DRIVE consists of approximately 60 projects in a \$150 million research program linking information technology and transportation. Individual projects are being undertaken by international consortia consisting of private firms, government agencies and research institutions. DRIVE is focusing on infrastructure requirements, operational aspects and technologies of particular interest to public agencies responsible for transportation systems.

The general objectives of DRIVE are:

- * to enable the timely adaptation of the highway infrastructure and services to take advantage of the opportunities opened up by technological advance;
- * to exploit the opportunities for synergy between road and telecommunications infrastructure developments;
- * to promote the consistent development of IVHS technologies so as to facilitate the development of an internal European market;
- * to contribute to the international competitiveness of the equipment and service industries;
- * to stimulate collaboration between government and industry in analyzing opportunities and requirements, basic research and development of

infrastructure technologies, and the development of specifications and initial system testing;

- * to support international standardization in IVHS and for related equipment and services; and
- * to contribute to the timely common adaptation of an appropriate regulatory framework for advances in IVHS.

Within these general objectives, the overall goal of DRIVE is to make a major contribution to the introduction of an Integrated Road Transport Environment (IRTE) offering, by 1995, improved transportation efficiency and a breakthrough in road safety.

Sixty DRIVE projects began in January 1989. Many of these were completed at the end of 1990, though some projects involve a further year of work, running through 1991. Planning is now in progress for a further round of projects within a DRIVE-II program. This would take many of the systems from the preliminary research stages of DRIVE through to large-scale field trials. Funding for the DRIVE-II effort is currently proposed at a level of approximately \$250 million.

The Advanced Transport Telematics (ATT) program, the official name for DRIVE-II, is almost fully defined. It is envisioned that the call for proposals will be approved by the European Commission in early 1991. Proposals will be due by the fall for work to start before the end of the year. The program will be completed by the end of 1995.

The ATT workplan identifies seven areas for pilot projects based mainly on the results of the initial DRIVE program. These are:

- * demand management;
- * traffic and travel information;
- * integrated urban traffic management;
- * integrated interurban traffic management;
- * driver assistance and cooperative driving;
- * truck fleet management; and
- * public transit management.

Within the framework of these seven areas, the main emphasis will be on pilot projects. Other aspects of the new program, however, will also be devoted to systems engineering and evaluation, and technical development.

Two further European initiatives have already started in order to involve so-called infrastructure owner-suppliers. The first of these is POLIS, which is coordinating fifteen major European cities with a further eighteen involved as observers. The intention is that through POLIS, the appropriate city authorities

will coordinate their own IVHS activities and prepare proposals for EC funding. CORRIDOR, the sister initiative, will examine interurban areas suitable for use as IVHS operational test sites.

2.4 Japanese initiatives

Japanese researchers have been investigating a range of advanced transportation technologies since the 1960s. Early work examined traffic management systems, prior to a shift of emphasis toward development of driver information technologies. More recently, automated vehicle control projects have been undertaken in Japan. The main Japanese IVHS initiatives currently being carried out or proposed include RACS, AMTICS, VICS and SSVS.

RACS (Road-Automobile Communication System), described in more detail in Chapter 3 of this report, has involved the development of a short-range, high data rate microwave communications system. This will be used for a number of road-vehicle communication applications. These include beacon transmissions for the correction of positional errors in vehicle location systems; the provision of a communications link for an externally-linked route guidance system; and the ability to pass individual messages or data for display on in-vehicle units.

AMTICS (Advanced Mobile Traffic Information and Communication System), also described in Chapter 3 of the report, is an integrated traffic information and navigation system, being developed in Japan under the guidance of the National Police Agency. The system will display on screen in each vehicle traffic information gathered at Traffic Control and Surveillance Centers managed by the police in 74 cities. The major benefit of AMTICS will be its ability to display in real time, not only the vehicle's current position and route, but also information on traffic congestion, regulation, road work and parking.

Both RACS and AMTICS are now entering their final implementation stages. These systems are currently being coordinated within an initiative known as VICS (Vehicle Information Communication Systems). VICS is a joint effort between the Ministry of Construction, the National Police Agency, and the Ministry of Posts and Telecommunications.

One of the major IVHS programs currently being planned is the Japanese SSVS (Super Smart Vehicle System) initiative. This aims to promote the research and development of IVHS technologies, particularly those concerned with highway safety. The initiative is targeted toward technologies for implementation in the highway environment within the next 20 to 30 years. SSVS will address a number of factors, including the following:

- * technical, social and economic issues concerned with the development and introduction of IVHS technologies;
- * evaluations of the needs of IVHS in terms of safety, efficiency and convenience;

- * analysis of the fundamental characteristics of in-vehicle units based on technological capabilities;
- * investigation of man-machine interfaces and human factors issues; and
- * policies concerning technology research, development and evaluation.

Current proposals for SSVS suggest that it will initially be a two-year research effort. During this period, the program will investigate future socioeconomic conditions and vehicle requirements, as well as planning research and development projects and related activities. After two years of preliminary study, the Japanese Ministry of International Trade and Industry will decide whether SSVS should be adopted as the country's major IVHS project.

Prospective participants in SSVS cover a range of Japanese academic institutions and industrial firms, including the majority of the large automobile manufacturers. The initiative will also involve the participation of the Japanese subsidiaries of two European car makers, Volvo and Mercedes-Benz.

2.5 Recommendations

Two major lessons can be learned from this brief review of IVHS initiatives elsewhere in America, in Japan and in the European Community. These two main factors which emerge can be summarized as follows:

1. Like electronics and automobile manufacture, IVHS is a single world market. It makes no sense at all to think in terms of unique systems for Phoenix, for Arizona, for the western states or for the U.S. Not even North America as a whole can constitute a trading block of sufficient weight to dominate the development of new IVHS technologies. Thus, effective, well coordinated and meaningful links to overseas efforts, leading to open, non-proprietary international standards, are an essential base for economically effective state and national IVHS programs.
2. The European Community's DRIVE and PROMETHEUS programs have set the pace in IVHS, ahead even of the Japanese who are now responding with innovative programs like SSVS. DRIVE and PROMETHEUS are characterized by their multi-center cooperative frameworks, set within genuine public-private sector joint research programs. Separate and inevitably partial state programs will not be as effective in meeting the challenge of IVHS. Thus, interstate and international cooperation and joint working is an essential requirement at a high level of the Arizona IVHS program, ensuring synergistic gains through technology transfer at all levels of the development process.

These two principles have been major factors in developing the program and organizational proposals of the remaining chapters. They are also recommended as a focus for continued work on Arizona's program and on broader, cooperative IVHS development efforts over the months ahead.

3. ADVANCED TRAVELER INFORMATION SYSTEMS

3.1 Introduction

This chapter describes systems designed to provide drivers with information on highway conditions and route availability. Driver information systems can assist motorists in making decisions on appropriate route choice and in following the chosen route for a particular trip. Improved motorist route selection and route following should lead to more efficient utilization of the highway network, and consequent benefit to traffic as a whole.

Research studies carried out in the U.S. and Europe [1, 2, 3, 4, 5] have shown that many drivers are currently inefficient in selecting and following a route, for a variety of reasons. This inefficiency leads to excess travel, contributing to unnecessary congestion of certain routes and consequent wastage of resources which can amount to many millions of dollars every year in a large metropolitan area. Excess travel can generally be defined in terms of time, distance or cost, or some combination of these criteria.

Providing drivers with accurate information can help remove a proportion of excess travel caused by driver inefficiency in carrying out the three key trip activities of route planning, route following and trip chain sequencing.

Route planning takes place largely at the pretrip stage. Conventionally, drivers plan their journeys either using maps or from information held in memory. Drivers can use any of a variety of route selection criteria, and are typically considered to allocate an "impedance" to each route, based on their personal criteria. The minimum impedance route is then selected for the trip being planned. Re-planning may take place en route as drivers become aware of traffic conditions, causing a conceptual change in the relative impedance of alternative routes. Inefficiency in route planning can be caused by inadequate attention to alternatives, or planning on the basis of inadequate or inaccurate information.

Route following involves implementation of the trip plan. This activity is conventionally aided by road signs and maps, to supplement drivers' recognition of their surroundings and sense of direction. Inefficiency in the route following task generally results in drivers losing their way, taking unplanned detours, or making other unnecessary deviations from their planned progress along a route.

Trip chain sequencing concerns complex trips which have multiple stops or multiple purposes [2]. Such a trip chain can incur significant excess travel if the sequencing of stops or trip segments is not optimized. Similarly, use of several single trips rather than a single, complex trip can result in a considerable amount of excess travel.

A number of approaches exist for assisting drivers in one or more of these activities by providing improved information. The remainder of this chapter covers the main approaches and describes previous experience of their use.

3.2 Electronic route planning

Sources such as maps or memory can, at best, only supply historic data on which routes are available. Supplementary information is required to describe transient road and traffic conditions, and to show which route is 'best' at any particular time. One possible solution to this need for additional real-time pretrip information lies in the development of electronic route planning and information systems [6].

Electronic route planning systems link minimum path computer algorithms to highway network databases. Minimum paths can be determined in terms of journey time, distance or cost. Users access the route planning computer either directly or over a phone line, and see details of their optimum route displayed or printed out. Development of most electronic route planning systems has taken place within the last ten years. Some of the significant developments are described below.

In the U.S., an electronic route planning system has been developed by Navigation Technologies, Inc. (Figure 3.1). This selects destinations from a structured database, using a look-up table. The system has been used by rental car firms to provide customer directions.

In the U.K., a system known as AUTOROUTE is currently being marketed for route selection [7]. AUTOROUTE is a prejourney route planner for microcomputers based around standard U.K. road maps. A route optimization module enables the system to identify a user's optimum route between a specified origin and destination. Optimization is based upon time, distance and operating cost according to parameters specified by the user. An abnormal routing module capable of considering traffic data from several sources is also currently being developed.

Electronic route planning facilities are also receiving attention elsewhere in Europe [8, 9]. The French TELETEL videotext system [10] comprises many interactive services including a route planning service called ROUTE. The service is accessed through remote videotext terminals which are connected by phone to service suppliers. The database for ROUTE contains network information, together with current data on highway maintenance and construction activities, road conditions and weather.

Also in France, the ANTIOPE service provides up-to-date traffic information which can be used by motorists in planning routes. ANTIOPE is not an interactive system, but collects and displays 30-40 pages of traffic information on a regional basis via a teletext TV service. ANTIOPE contains maps showing the congestion on major roads in selected areas which are updated at hourly intervals based on data collected by the highway patrol.

The U.K. Automobile Association (AA) has developed a similar service called ROADWATCH [11] which provides traffic information to radio stations, TV and teletext services. This networked system operates around a database which is kept up-to-date with the latest details of variations in road conditions due to weather, highway maintenance or accidents.

DriverGuide
ELECTRONIC DRIVING DIRECTIONS



DriverGuide
ELECTRONIC DRIVING DIRECTIONS



DriverGuide
ELECTRONIC DRIVING DIRECTIONS



--FROM THIS LOCATION AT 1301 S 46TH ST RICHMOND
--TO SAN FRANCISCO INTERNATIONAL AIRPORT AT I SF
AIRPORT TERMINAL LOOP SAN FRANCISCO
--ABOUT 26.8 miles, 44 MINUTES--
-----Copyright 1987 K & C (SF2.0.7, 2.4.c)

Proceed E on 46TH ST.

Drive 0.1 miles on 46TH.
Turn RIGHT onto MEADE ST.

Drive 0.4 miles on MEADE.
Take I-580 SOUTH ramp to the LEFT.
Merge onto I-580 FRWY.

Drive 1.6 miles on I-580.
Take I-80 WEST exit.
Merge onto I-80 FRWY.

Drive 5.4 miles on I-80.
Continue onto SAN FRANCISCO-OAKLAND BAY BRIDGE .

Drive 3.2 miles on SAN FRANCISCO-OAKLAND BAY BRIDGE.
Continue onto I-80 FRWY.

Drive 1.7 miles on I-80.
Turn SLIGHT RIGHT onto US-101 FRWY.

Drive 11.3 miles on US-101.
Take SAN FRANCISCO AIRPORT exit.
Turn SLIGHT LEFT onto AIRPORT ACCESS RD.

Drive 1.3 miles on I-580.
Take BAYVIEW AV exit.
Turn SHARP LEFT onto BAYVIEW AV.

Drive 0.3 miles on BAYVIEW.
Turn SLIGHT RIGHT onto MEADE ST.

Drive 0.4 miles on MEADE.
Turn LEFT onto 46TH ST.

Drive 0.1 miles on 46TH to 1301 S 46TH ST RICHMOND.

Figure 3.1 Electronic Route Planning

At a pan-European level, there is a developing system known as ATIS which aims to provide pretrip information, both on road traffic conditions and on other aspects important to tourists. ATIS is based around the existing ERIC (European Road Information Center) facility, which is coordinated by the AIT (Alliance Internationale de Tourisme) in Geneva, Switzerland. Important traffic information is reported to the Geneva center by the police and motoring organizations in each of 12 European countries. Here it is processed and the resulting information transmitted back to each country, for dissemination via the motoring organizations.

3.3 Traffic information broadcasting systems

Traffic information broadcasting systems can potentially play an important role in keeping the motorist updated on current network traffic conditions, enabling drivers to adapt and replan routes as necessary. Systems can be used to warn drivers of various conditions including recurring congestion, short-term holdups caused by a traffic incident, or preplanned activities liable to cause congestion such as highway construction and maintenance.

In the U.S. and Japan, traffic information broadcasting is provided by highway advisory radio (HAR). HAR is a short-range broadcast service provided to the motoring public through standard AM car radios [13, 14]. In the U.S., travelers' information stations (TIS) have been authorized to provide this service since 1977. HAR is operated by local and federal government agencies under rules that limit location, extent of coverage, and message content. This authorization and the rules covering HAR services are contained within Docket 20509 of Part 90 of the Federal Communications Commission (FCC) Rules and Regulations.

HAR stations can be authorized to broadcast on either 530 kHz or 1610 kHz, which are just below and above the standard AM broadcast band, respectively. Transmissions on these frequencies can be received by most standard AM car radio receivers, and the system therefore has the advantage that motorists do not have to purchase any special in-vehicle equipment. However, because of the localized nature of the service, motorists must be notified by appropriate signing when approaching an area serviced by HAR in order to tune their radios to the appropriate frequency (Figure 3.2).

In 1980 the Federal Highway Administration (FHWA) initiated a program to develop automatic highway advisory radio (AHAR) [15]. AHAR avoids the need for roadside signing and manual tuning by using a subsidiary FM receiver. This automatically mutes the car radio and tunes to the correct frequency (45.80 MHz) on entering the coverage area of the AHAR transmitter. The radio is retuned to its normal state after the message has been repeated and received twice. The system prototype was developed to the stage where it was technically proven, though institutional barriers have so far prevented the transition from HAR to AHAR.

Other traffic information broadcasting systems include the West German system known as ARI (Autofahrer Rundfunk Information) [16, 17], developed by Blaupunkt. ARI is widely used in Germany and parts of Austria, Switzerland and Luxembourg.

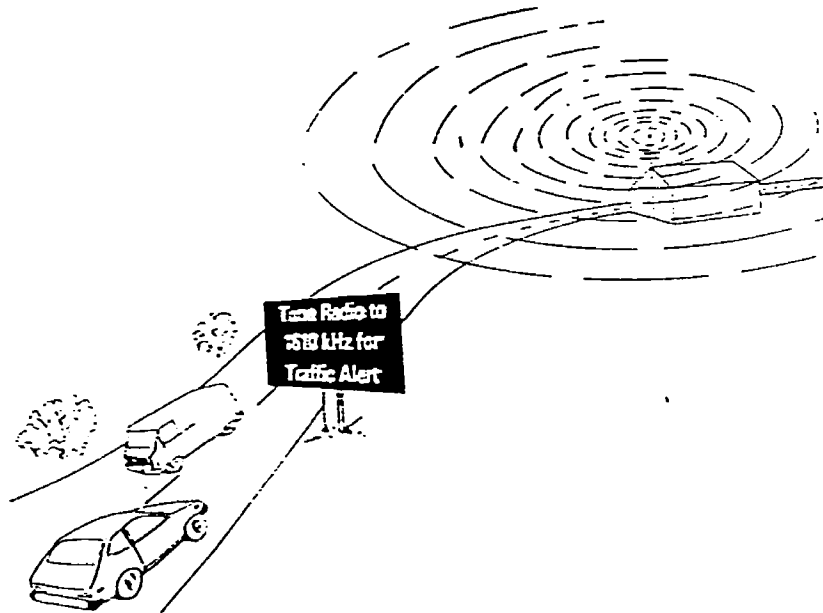
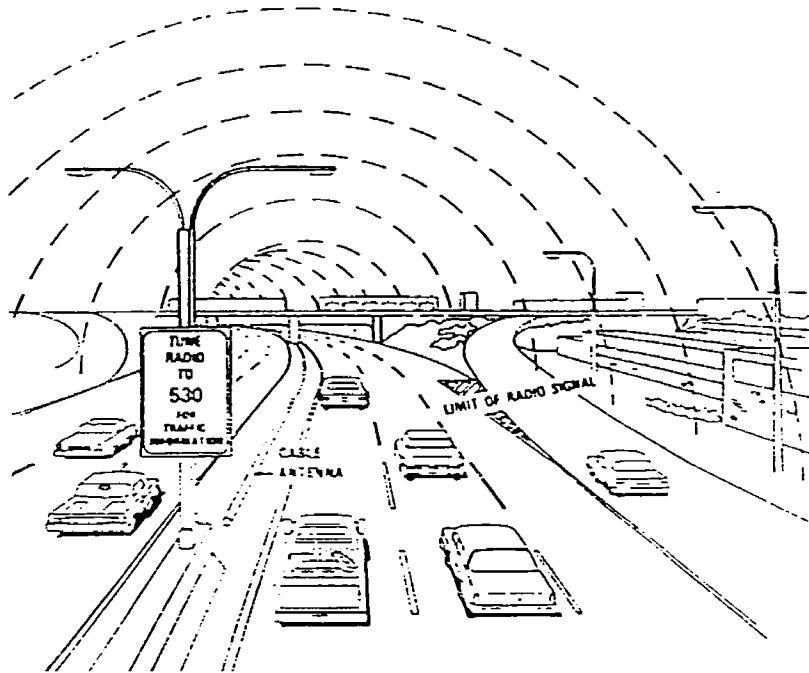

Figure 3.2 Highway advisory radio
(Source: Reference 13)

A modified version known as ARI-2 has also been implemented in parts of the U.S. [18].

In West Germany, traffic information is broadcast at specified times over a network of about 40 conventional FM radio stations, each transmitting on its own frequency. Because of the characteristics of FM transmissions, the range of each station is limited. With such a system using a large number of short range stations, it is important to provide a tuning aid to select the frequency of the station covering the area in which the motorist is traveling. The principal function of the ARI system is therefore to assist the motorist in tuning to a station which is providing traffic information, and to alert the driver when a traffic broadcast is imminent. To decode and utilize these ARI signals, vehicles need to be fitted with a specialized form of receiver. In West Germany, more than 80 percent of car radio receivers have an ARI capability.

The sources of traffic information for ARI are made up mostly of observations by police and highway agencies. The information flow process necessarily involves detection of a major change in traffic conditions and its cause; transmission to a radio station; and broadcasting to the motorist. This inevitably involves a significant delay, which can result in the information being out-of-date by the time it is received.

In an attempt to reduce this delay, an enhanced version of ARI has been developed called ARIAM [19, 20]. ARIAM stands for "ARI aufgrund Aktueller Messdaten," which can be translated as ARI with Actual Measurement. The objective of ARIAM is to automate the process of detecting changes in traffic conditions, disseminating that information to the public using the established ARI network. ARIAM uses automatic incident detection equipment as the main basis for detecting these changes. Initial tests of the system have shown that information about road and traffic conditions can be made available to the traffic control center and the motorist around 10-15 minutes earlier than a system relying on non-automated information collection.

A system which will eventually supersede ARI is the Radio Data System (RDS) of the European Broadcasting Union (EBU). This is a system which enables digitally-encoded data to be inaudibly superimposed on the stereo multiplex signal of a conventional FM broadcast. These data are decoded by a suitably-adapted car radio, which can automatically select the strongest of several traffic announcement programs when a driver leaves the reception area of one transmitter [21].

The Radio Data System has been under development by the EBU since 1974. It provides a unified standard for automated tuning, station identification and other receiver functions. The RDS Specification [22] was finalized in 1983, after coordination with radio receiver manufacturers confirmed that RDS objectives had been achieved. International efforts are currently taking place to develop standards for the RDS Traffic Message Channel (TMC). A specialized receiver is required to decode the traffic information, which can then be displayed either as text or synthesized speech. Such a system is particularly attractive from a European perspective because digital transmissions can be interpreted in the language of the driver's choice.

Studies are also being undertaken in countries outside Europe to investigate the possibilities of implementing RDS-TMC. These include Canada and Hong Kong. In the U.S., Chrysler has been carrying out trials of RDS traffic information in the Detroit metropolitan area.

Another traffic information broadcasting system of interest is EMERAUDE, developed in France [7]. This is based around the cellular radio-telephone system which will be installed over the entire French road network during the next ten years. The cellular system has been designed primarily for the transmission of personal voice communications, but has some spare capacity which will be used by EMERAUDE to transmit numeric data. This will include weather conditions, road passibility, traffic conditions and alternative route recommendations. Data will be collected by the police and road authorities, and will be updated on an hourly basis.

The onboard EMERAUDE equipment is a dedicated unit which receives, decodes and stores data. The driver can program the onboard unit according to the geographical areas in which traffic data are required. Data are passed on to the driver using a voice synthesizer, or can optionally be represented on an in-vehicle map display. The French telecommunications authority is currently in the process of implementing a trial of the EMERAUDE system in Paris.

While systems such as RDS-TMC and EMERAUDE are currently entering demonstration and field trial stages, however, a real-time in-vehicle traffic information system has already been made commercially available in London, U.K. [23]. The system, known as Trafficmaster, collects traffic information on major roads within a 35-mile radius of London using 115 sets of bridge-mounted infrared sensors. Detected congestion is broadcast to a portable in-vehicle unit using a VHF paging network. The screen on the receiver unit displays the motorway network with holdups pinpointed in red to allow the driver to make rerouting decisions. System portability allows the unit to be operated in the home or workplace to provide pretrip planning facilities.

The system manufacturer plans to extend Trafficmaster's area coverage to the British Midlands in 1991 and the complete U.K. motorway network by 1993. Receiver units can be purchased by users for approximately \$860 with a \$35 per month subscription charge. Message paging facilities can be provided for an additional \$33 per month.

In the U.S., work is currently being undertaken by the Federal Highway Administration into the development of an in-vehicle safety, advisory and warning system (IVSAWS) [24]. This will provide an electronic extension of the driver's line of sight to warn of signs or hazards that are not clearly visible due to roadway curves, vegetation, poor visibility or other obstructions. The IVSAWS concept involves the use of radio transmitters mounted on regulatory and safety warning signs, on emergency or maintenance vehicles, or temporarily placed at roadway hazards. Upon activation, these would transmit short-range encoded messages to approaching motorists. Messages would be decoded by in-vehicle receivers and displayed to the driver, providing sufficient time for precautionary action to be taken.

3.4 Onboard navigation systems

Onboard navigation and location systems are a further area of motorist information technology. These systems provide the motorist with information on his current location and how this relates to his destination. In some cases, onboard navigation systems also provide advice on the best route to take. This information is calculated and presented by a self-contained vehicle unit, which does not require any external link to a roadside infrastructure.

Onboard navigation systems are generally of most use to the motorist in conducting the route following task. Systems which provide actual guidance information can also be used for the route planning task. However, without any information about real-time conditions on the traffic network, onboard navigation systems can only reduce motorist inefficiency which occurs under steady-state conditions.

A large number of self-contained vehicle navigation systems have been developed by manufacturers in the U.S., Europe and Japan. Several of these have passed through development stages but have not yet been implemented. Others have been tested on the highway and some are currently commercially available to motorists. The systems can be divided into the following three categories:

- * directional aids;
- * location displays; and
- * self-contained guidance systems.

Directional aids typically use dead reckoning (DR) to provide navigational information to the motorist. DR utilizes measurements made by distance and heading sensors to continuously compute a vehicle's location relative to a known starting point. Several different technologies can be used to monitor both distance traveled and vehicle heading [25]. The odometer is the most common approach for distance measurement. Heading sensors for DR include the magnetic compass and the gyrocompass.

Even the most precise DR systems accumulate error with distance traveled, and therefore require periodic reinitialization. Accuracies of around 2 percent of distance traveled are normally achieved. Reinitialization can be achieved in a number of ways, such as through a network of roadside proximity beacons, or by manual adjustment.

Proximity beacons work by local transmission of a location code, which enables a vehicle to learn its true current position. In practice, it may be uneconomic to deploy large numbers of such beacons purely for compensation of DR errors, and this approach is therefore not generally favored. Manual correction of the system position is required by some systems and has the advantage of being a low-cost approach. However, it reduces the utility of the system to the driver.

In-vehicle equipment for directional aids generally consists of a microcomputer, a keypad and a display unit [9, 26]. The motorist is required to enter position

coordinates for his trip origin and destination. The vector connecting the two positions is then calculated and its characteristics (direct distance and heading) are displayed in the vehicle. Heading is usually displayed as an arrow symbol which identifies the direction the motorist should take in order to reach his destination.

The system continuously updates the vehicle position and recomputes the vector as the vehicle progresses on its journey. New headings and remaining distances are then displayed to the motorist. Therefore, as the motorist approaches each intersection on his journey, he has available both a measure of how near he is to his required destination and the direction he should take to reach it.

Location displays show the motorist his current position on an in-vehicle display unit, frequently in the form of a point on a map display. These systems have the distinct advantage over directional aids that the actual road network is indicated by the system. However, location display systems only show the driver where he is in relation to an intended destination, and do not offer advice on the best route to take.

Vehicle position in location display systems is calculated using initial coordinates updated through use of DR or trilateration techniques. Trilateration involves the detection of radio frequency (RF) transmissions from three or more fixed points. Ranges to those fixed points are then calculated, effectively fixing the position of the vehicle.

Land-based trilateration techniques include use of systems such as Loran-C [27] and Decca [28]. Loran-C has shown potential for vehicle navigation systems in the U.S. However, problems with Loran-C for this application include lack of coverage of the central U.S. (known as the mid-continent gap), as seen in Figure 3.3. Also, problems are encountered in receiving Loran-C transmissions in urban areas due to multi-path reflections and obscuration of the signals. Additionally, positioning accuracies are only of the order of 600 feet, which may be inadequate, particularly in urban areas.

Satellite trilateration techniques are currently based around the U.S. Navy TRANSIT system or the Navstar Global Positioning System (GPS). TRANSIT is a radio positioning system based on four or more satellites in approximately 600 nautical mile polar orbits, together with four ground-based monitoring stations [29, 30]. Ford's prototype TRIPMONITOR [31] system fitted in the "Concept 100" car in 1983 utilized TRANSIT, with a receiving antenna located in the trunk of the car.

TRANSIT, however, will shortly be superseded by Navstar GPS [32]. Navstar GPS is a space-based radio positioning, navigation, and time-transfer system that will become fully operational in the early 1990s. GPS has the potential for providing highly accurate three-dimensional position and velocity information along with Coordinated Universal Time to an unlimited number of suitably equipped users.

However, GPS is not without problems [33]. First, GPS receivers are complex and costly. Second, signal disruption caused by tall buildings, tunnels and bridges leads to positioning discontinuities, particularly in built-up urban areas. Augmentation of GPS-based systems with DR capability is therefore necessary for a continuously effective onboard navigation system.

GPS has been considered as the basis of onboard location display systems by several manufacturers, including Chrysler, General Motors and Ford. Chrysler demonstrated its CLASS prototype system based on GPS at the 1984 World Fair [34].

At present, however, the market place for location-display onboard navigation systems is dominated by systems which are based primarily on DR. One of the earliest successful attempts at producing a DR-based location display system is the Japanese Honda ELECTRO-GYROCATOR [35]. This device relies on a helium rate gyro to sense heading and an electronic odometer to dead reckon the position of the vehicle.

More sophisticated DR-based location display systems include the ETAK NAVIGATOR, Car Pilot and Philips CARIN. The ETAK system [36, 37] is the only onboard navigation system which has been actively marketed in the U.S. This uses DR augmented by map-matching to track vehicle location on a CRT map display. The ETAK system incorporates a flux-gate magnetic compass as well as differential odometry for DR inputs, and uses compact disks or tape cassettes to store digital map data.

The map-matching augmentation of the DR system is based on the fact that vehicles are generally constrained to travel on the highway network. This makes it possible for algorithms to use a map as the basis for matching the pattern of the vehicle's indicated path (from DR) with that of the feasible path on the map, and so determine vehicle position at specific points where the pattern clearly changes, such as at a turn in the road.

In Europe, the ETAK system is currently being sold under license by Bosch-Blaupunkt, using the name Travelpilot. The system was launched in West Germany in May, 1990, and reportedly sold over 1,000 units within its first year. However, plans to introduce the system in France and the U.K. have been delayed after feedback from German users indicated insufficient network coverage. The German system contains only the autobahns, main routes and large towns. In contrast, the Travelpilot version available in the Netherlands has digitized maps for the entire Dutch highway network.

Competition for the Bosch Travelpilot will soon be provided in the form of the Dutch Car Pilot system. This is scheduled for official launch in the European market in January, 1991. Car Pilot will use wheel sensor-based DR and map matching techniques to establish vehicle location and desired destination. Road networks will be stored on CD-ROM, digitized from 1:10,000 maps and augmented by in-depth video data collection. CDs will need to be updated approximately every 6 months to reflect changes in the highway network.

The likely cost for the Car Pilot system is estimated at around \$5,000. Optional enhancements will provide automatic vehicle location and route logging. This

latter facility will enable vehicle location to be recorded for every map-match. The data will then be stored on floppy disk for subsequent route reconstruction.

The Philips CARIN system [38, 39] currently exists as a prototype version. This system uses a compact disk capable of storing 600 Mbytes of data, sufficient to hold a digital map of a very large area. For the future, Philips proposes that the system will provide actual routing instructions, and will be capable of using GPS for positioning as well as its current DR capability. Further development of CARIN is being undertaken as part of the European CARMINAT project within the Eureka framework, in a cooperative effort between Philips, Renault and Sagem of France.

Self-contained guidance systems provide the motorist with actual routing advice, as well as vehicle location information. To provide this routing advice, a more comprehensive description of the road network must be stored in the vehicle unit, together with an algorithm which can compute an optimum path through the network.

In some systems, such as ROUTEN-RECHNER, EVA, and ROESY, a description of the highway network is stored in memory in terms of the intersections (nodes) and the impedance of the road links which connect them. A suitable algorithm can then be used to compute the minimum impedance path between any two intersections. Distance is most commonly used as a measure of impedance, because it is the easiest to establish, but time or cost can be used as criteria for route selection if sufficient data are collected.

In other systems, the network description is precompiled to provide signpost data for each intersection, with the resolution needed to give guidance to every other intersection in the network. This precompilation process can employ a distance, time, or cost criterion.

Self-contained route guidance systems can again use DR or a trilateration technique as the basis for fixing the vehicle location. In each case the motorist must initialize the system by keying in codes for his required destination using a keypad. The system then computes the best route through the network using an appropriate minimum path algorithm.

Presentation of the routing advice to the motorist may be achieved through a variety of interfaces. These include alpha-numeric displays, graphic displays, speech synthesis units or other audio signals. Visual displays may either be located at dash panel level or may take the form of head-up displays, similar to those used in aircraft.

One of the earliest successful attempts at providing routing instructions to motorists via an in-vehicle system was ARCS (Automatic Route Control System), developed in the U.S. by French [40] during the early 1970s. This used DR augmented with map-matching to track the vehicle location. Routing advice was provided by preprogrammed audio instructions which were developed off-line during a pretrip route planning process.

ROESY may have been the first system to develop routing instructions in the vehicle. This prototype allowed the user to specify a network of up to 300 nodes and 450 links, and to define both the lengths and impedances of the links.

Origin and destination codes were then entered on the keyboard, and a speech synthesis unit was used to give routing instructions to the driver as he progressed on his journey. The device was not developed beyond the demonstration phase.

A similar principle was used by the German ROUTEN-RECHNER from Daimler-Benz [41]. This was primarily aimed at providing route guidance on the German autobahn network. ROUTEN-RECHNER used minimum distance as its criterion for optimum route selection and stored details of intersections and connecting roads in memory. The routing advice was presented to the motorist via audio messages or on an alpha-numeric display. As with ROESY, it was assumed that the driver followed the instructions implicitly, as measurement of distance traveled dictated the timing for displaying instructions.

Also in Germany, the EVA (Electronic Traffic Pilot for Motorists) system developed by Bosch-Blaupunkt [42] was developed specifically for metropolitan areas. EVA used DR and digital map-matching techniques to determine the vehicle position, and utilized this positioning information in giving appropriate instructions. Instructions were presented aurally via a speech synthesizer unit and also visually by a liquid crystal display unit.

In France, a prototype in-vehicle map display and routing system called DANA has been developed [7]. This uses road network data stored in an onboard computer to make recommendations on the shortest path to a desired destination. A visual display is used to provide turning instructions during a journey. DANA's location subsystem uses DR, with computer algorithms employed to minimize the deviation between the measured and the actual vehicle position.

Finally, Plessey has developed a self-contained route guidance system known as PACE (Plessey Adaptive Compass Equipment). PACE [43, 44, 45] is based on DR using an electronic compass to sense vehicle heading. This is coupled to a map database and minimum path software, with routing instructions presented on a small visual display panel. Plessey claims an accuracy of 1 percent of distance traveled.

3.5 Externally-linked route guidance systems

Externally-linked route guidance systems comprise all electronic route planning and route following aids which have a communications link from in-vehicle guidance equipment to an external system providing network or traffic information. The advantage of these systems over self-contained onboard navigation systems is that they can potentially take account of real-time traffic conditions, providing additional benefit to the motorist in conducting his route-planning and route following functions. The extent and usefulness of the real-time information provided depends on the particular system configuration under consideration.

Externally-linked route guidance systems can be divided into two main categories: those linked by a long-range communications or broadcasting channel to a traffic

information service; and those with a short-range communications link to a roadside infrastructure. These are each described in the following paragraphs.

Long range communications systems are limited to receiving information on major traffic incidents or delays reported by police or highway agency personnel. They would be unlikely to take account of normal variations in traffic conditions, due to the absence of an effective monitoring network in recording transient traffic conditions. Possible approaches in this first category are route guidance systems which utilize mobile cellular radio, systems which are linked with RDS, and systems using digital broadcasting such as AMTICS.

Cellular radio [46] provides a mobile radio telephone service using a modular coverage plan. A cellular radio could be used in conjunction with a modem and onboard computer unit to interrogate a traffic condition database held on a remote computer. This database could be used to update versions of the digital map information held by an onboard route guidance unit, reflecting known changes in network conditions. Alternatively, the information could simply be presented to the driver to supplement information supplied by an onboard route guidance unit.

Coded network traffic information broadcast using RDS could also be used to update map databases held in memory by an in-vehicle unit, or again could be presented separately to the motorist as additional information. With RDS, the driver would not need to take any specific action to interrogate an information source, but would simply need to have the RDS receiver switched on. Information received from RDS would be stored in memory, updating previous data records.

A current Japanese initiative in long-range externally-linked route guidance has been set up by the Japan Traffic Management Technology Association. Proposals for AMTICS have been developed in cooperation with the Japanese Ministry of Posts and Telecommunications (MPT) and a number of private corporations.

AMTICS is an integrated traffic information and navigation system. Traffic information is collected by Traffic Control and Surveillance Centers managed by the police and located in 74 cities. The information is reprocessed at the AMTICS data processing center and then broadcast to vehicles. The broadcasting system is a radio data communication system called teleterminal. The equipment in vehicles will consist of a display screen, a compact disk read-only memory (CD-ROM) reader for retrieving map information, and a microcomputer to calculate the vehicle's position and to superimpose it on the display.

In 1987 a Conference on the Practicability of AMTICS was organized in which 59 private corporations participated. Twelve groups of companies have since joined together to develop elements of the system within an overall, coordinated framework. Within this framework however, each group of companies is pursuing its own system development program. An experimental system was started in Tokyo in 1988 and the first commercial system was made available in Tokyo and Osaka in 1990.

Short-range communications systems, which make up the second category of externally-linked route guidance systems, also include several different approaches [8]. These approaches are responsive to traffic conditions to varying

degrees, and include both one-way and two-way vehicle-roadside communications. Some of these systems have been tested in the field, while others have not progressed beyond the conceptual development stage.

Data received by the in-vehicle unit from the roadside infrastructure are usually location parameters enabling the vehicle's position to be determined, and/or updates of road network and traffic conditions, which are used for route guidance purposes. In two-way systems, data sent from the vehicle may comprise vehicle type, destination and journey times over previous links of the network. This latter information is the essential feedback needed to realize the possibility of fully-responsive real-time route guidance.

At the simplest level, a basic "beacon" system configuration with low data rate roadside-vehicle communication provides similar benefits to a self-contained onboard route guidance system. This configuration operates by equipping key points on the highway network with data transmission beacons, which continuously emit unique codes identifying particular locations. Techniques include use of inductive loop, radio frequency, microwave or infra-red transmissions.





Vehicles must be equipped to receive and decode the beacon transmissions, and also need an in-vehicle unit comprising a keypad, a microprocessor, a display unit, and a map database. If beacons are very closely-spaced, no DR or other onboard location sub-system is needed. Alternatively, with less frequent beacons, a self-contained onboard route guidance system is required, with beacons serving to correct accumulated positional errors.

A second level of system complexity provides a limited degree of responsiveness to traffic conditions. In this configuration, rather than simply transmitting a location identifier code, each beacon transmits part of an electronic map, at high data rates. This is used by in-vehicle equipment to calculate route guidance advice, and avoids the need for each vehicle to carry a detailed map database for the whole network.

The highest level of route guidance system complexity provides a two-way communications link between the vehicle and the roadside infrastructure. The two-way link enables each vehicle to supply the infrastructure with journey time information on the section of network it has just traveled, as well as receiving information on alternative routes ahead. This floating car information is used by a central computer to update a continuously-changing model of network conditions. This model is used as the basis for supplying routing advice to motorists.

Systems which utilize two-way communications links in this manner are potentially able to operate in a fully-responsive mode, taking full account of changing traffic conditions. The advantage of this type of system over an onboard navigation system is illustrated in Figure 3.4. A self-contained onboard navigation system treats determination of the optimum route between two points as a two-dimensional problem, since the impedance along each link between the two points is assumed to be fixed. However, a fully-responsive route guidance system treats the journey between the two points as a three-dimensional problem, whose link impedances vary with time as network conditions change. Optimum routing

Situation-related routing must be performed on several time planes t_1 to t_n

-  Situation-related journey time
-  Unalterable route section resistance
-  best route for private automobiles
-  best route for trucks

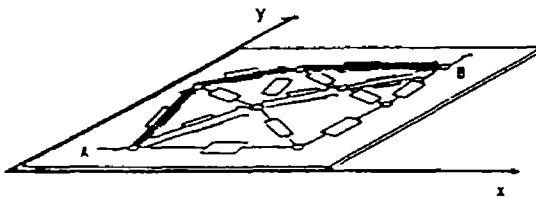

Situation-unrelated guidance:
a two-dimensional problem

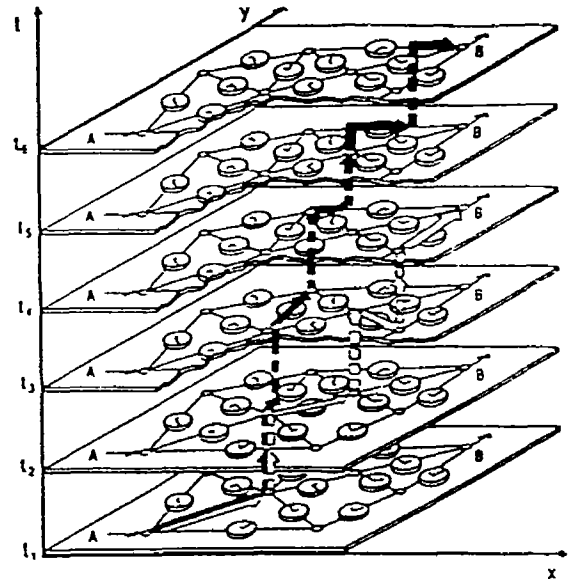

Situation-related guidance:
a three-dimensional problem

Figure 3.4 Simulation-related guidance
(Source: Reference 61)

advice is therefore provided at each decision point on the journey which is up-to-date and takes account of real-time variations in traffic congestion.

Route guidance systems have been a topic of research and development in several countries for over twenty years. Some of the earliest work was carried out in the U.S. in the late 1960s, with the investigation and development of a prototype Electronic Route Guidance System (ERGS) [47, 48]. The system concept was investigated by several organizations including General Motors [49] and Philco-Ford [50], under contract to the Office of Research and Development of the Bureau of Public Roads.

The ERGS concept was based around two-way communication between vehicles and a roadside beacon network infrastructure via in-pavement inductive loops and vehicle-mounted antennas. An in-vehicle console with thumbwheel switches permitted the driver to enter a selected destination code. The code was transmitted when triggered by an antenna as the vehicle approached key intersections. The roadside unit immediately analyzed routing to the destination and transmitted instructions for display on an in-vehicle panel.

In the ultimate system concept, ERGS was envisioned with each roadside beacon connected to a central computer, monitoring feedback on traffic conditions from the loop antennas to update a network database. The ERGS project was terminated in 1970, due to the high projected costs of the roadside infrastructure.

Japanese investigations into short-range externally-linked route guidance with two-way communications have been in progress since the early 1970s. The Comprehensive Automobile Traffic Control System (CACS) project [51, 52, 53], sponsored by the Japanese Ministry of International Trade and Industry (MITI), began in 1973 and ran for a six-year period.

The prototype CACS system demonstrated in Tokyo utilized inductive loop antennas for two-way communications between the vehicle and the roadside. As an equipped vehicle approached a CACS intersection, the vehicle type, an identification number and its coded destination (entered via an in-vehicle unit) were transmitted from the vehicle to the roadside. Routing and driving information were sent in the opposite direction. The roadside equipment was connected to a communications control center which processed travel time information derived from vehicles to continuously update a network condition database. Routing information updates were sent periodically from the control center to the roadside equipment.

The CACS project was completed in 1979, at which time the results of the project were given to a number of organizations concerned with traffic management. In order to carry out further development, building on CACS, the JSK Foundation [54] was established under the direction of the MITI. JSK involves 27 Japanese manufacturers of electronic equipment and motor vehicles.

In 1985, JSK organized a trial of an updated route guidance system in Tsukuba [55] to test out the most recent technologies. The system tested utilized overhead antennas, and the travel time between equipped intersections was computed by the in-vehicle unit. Full results of the evaluation have not been publicly released.

Other Japanese organizations are also active in the field of externally-linked route guidance. These include the Public Works Research Institute (PWRI) of the Japanese Ministry of Construction (MOC) and the Highway Industry Development Organization (HIDO) [56]. HIDO is a consortium of vehicle and electronics manufacturers. A study of externally-linked route guidance involving PWRI and HIDO members started in August 1986 [57] entitled RACS.

RACS involves further investigations of inductive beacon systems, together with experiments on microwave beacons. Trials conducted in 1987 utilizing inductive beacons and a prototype in-vehicle unit with DR between beacons, were of limited value in that only one-way communication was used. The advantage of the microwave approach over the earlier inductive systems lies in its high data transmission rate, which allows significant quantities of information to be passed between roadside beacons and vehicles. Further trials are planned which will incorporate two-way communications and will utilize the more recent microwave-based technology.

European investigations into short-range externally-linked route guidance have been principally carried out in West Germany. A number of West German manufacturers worked on developing both onboard navigation systems and externally-linked route guidance in the late 1970s and early 1980s. Route guidance systems of particular interest developed around this time were ALI and AUTO-SCOUT.

The ALI system (Autofahrer Leit und Informationssystem) [58, 59] was developed by Blaupunkt. Like ERGS and CACS, it utilized inductive loops for vehicle-roadside communication. It was designed principally for use on the German autobahn network. In the ALI system, the motorist keys in his destination as a seven digit figure using a small keypad. As an equipped vehicle approaches a freeway intersection, the destination code is transmitted via the inductive loop antenna to a roadside unit, which returns routing advice based on current traffic conditions.

Network conditions are monitored in ALI using the inductive loops and roadside units, which act as traffic volume counters over the freeway sections. This information is transmitted every five minutes to a central control computer, which calculates the current traffic situation and forecasts future flows on the various highway sections from the incoming data. Appropriate routing advice is then sent back to the roadside units, ready for transmission to equipped vehicles.

The AUTO-SCOUT system [60] was developed by Siemens and utilized infra-red technology for roadside-vehicle communications. AUTO-SCOUT was designed to include a more sparse network of beacons, with only around 20 percent of all significant intersections equipped. At each beacon, travel times on previous highway sections are transmitted from the in-vehicle unit to the roadside equipment, and then to the central computer. A description of the local road network and the recommended route to the next beacon are then transmitted back to the vehicle. Vehicle location and route-following between the beacons is achieved by a navigational computer utilizing DR.

More recently, the ALI-SCOUT system [61] has been developed in a cooperative effort by Bosch/Blaupunkt and Siemens, using experience gained from ALI and AUTO-SCOUT. ALI-SCOUT (Figure 3.5) is an infra-red based system which utilizes a roadside infrastructure consisting of post-mounted infra-red transmitter/receivers. It has many similar features to AUTO-SCOUT, including an in-vehicle DR unit for navigation between beacons. The basis for providing guidance information is travel time data, which are received from equipped vehicles at each beacon. This is analyzed in a central computer, which updates map information giving relative impedances of alternative routes held by the roadside equipment.

A large field trial of the ALI-SCOUT system known as LISB began in Berlin in June, 1989. Infrared beacons were installed at 250 intersections and at 10 additional freeway locations. The field trials were designed to permit an evaluation of system performance, driver acceptance and user benefit, using a fleet of 700 specially equipped vehicles [62].

In Britain, the Transport and Road Research Laboratory (TRRL) has taken an active interest in externally-linked route guidance systems since the early 1980s, when TRRL undertook a study [63] in association with Plessey Controls. Demonstration systems [64] utilizing inductive loop technology were set up on the TRRL test track and were used to show the practical feasibility of externally-linked route guidance.

This work formed the initial basis of proposals for a London AUTOGUIDE system [65, 66]. AUTOGUIDE will use a network of strategically located roadside beacons, a central computer and two-way communications with in-vehicle transceiver units, to provide drivers with real-time information on the best route to take between any two points. The elements of the AUTOGUIDE proposal are shown in Figure 3.6.

During the initial investigation of AUTOGUIDE [67], a choice was made between inductive loops or infra-red beacons for the roadside equipment to receive and transmit information. The main determining factors here were data transfer rate, cost and reliability. Post-mounted infra-red beacon systems are cheaper to install than loops and allow more information to be handled, with a potential data transfer rate of 500 Kbaud. A decision was made that further development and demonstration should concentrate on the infra-red approach, with a final commitment dependent on the results of field trials.

Work was subsequently carried out on the implementation of an AUTOGUIDE demonstration scheme in London [68]. The demonstration started in 1988 and utilized five beacons, sited along a corridor between Westminster and London's Heathrow Airport. In the demonstration beacons were not connected to a central computer, since the number of equipped vehicles and beacons was insufficient to collect detailed traffic data. Nevertheless, the demonstration was successful in verifying the infrared road-vehicle communications link and the format of the in-vehicle display unit.

The successful completion of the AUTOGUIDE demonstration led to the distribution by the U.K. government of a bid document for installation of an AUTOGUIDE pilot

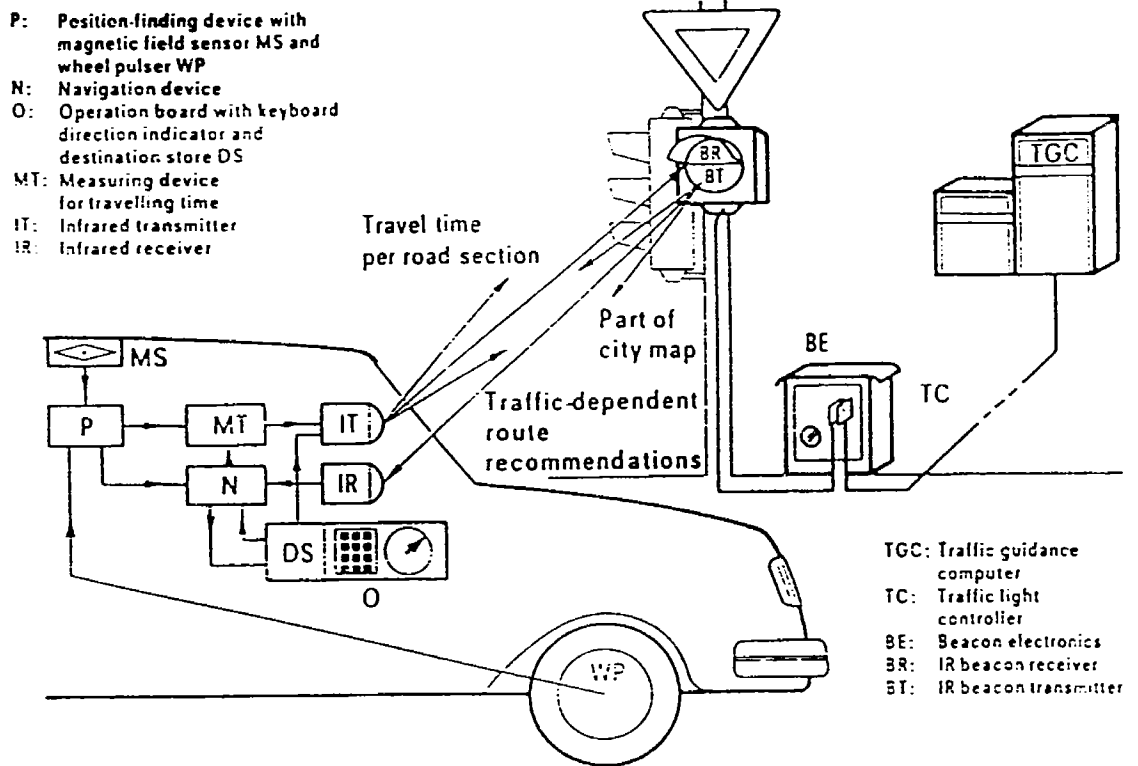

Figure 3.5 The ALI-SCOUT system

(Source: Reference 61)

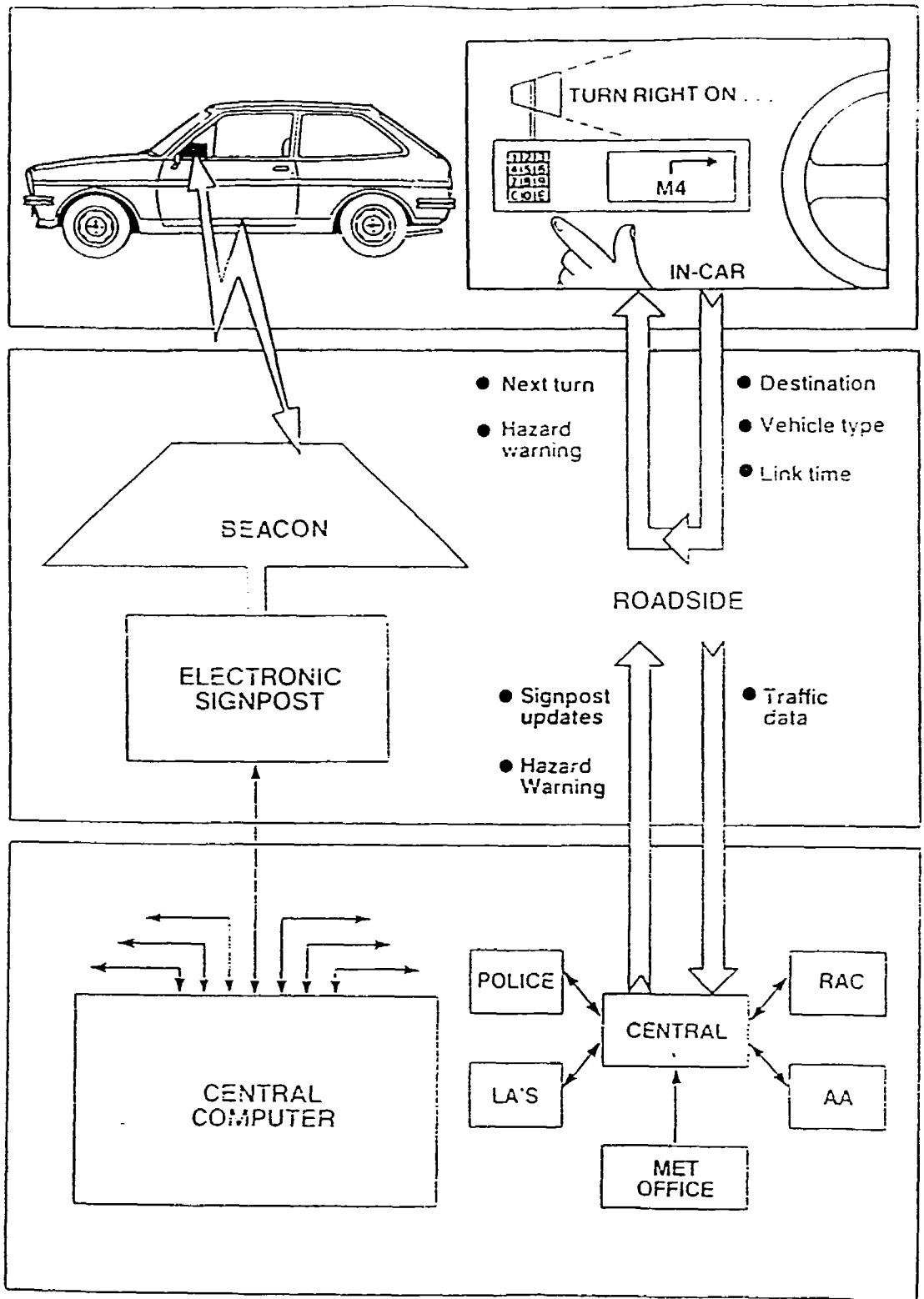

Figure 3.6 The AUTOGUIDE concept

(Source: Reference 67)

system. This would initially operate within the area encircled by the London beltway, before being extended to other parts of the country. GEC was selected by the U.K. government as the contractor for the AUTOGUIDE implementation. At the time of writing, however, negotiations between GEC and the U.K. government have yet to achieve agreement on the system licensing details. It is understood that one of the causes of the delay is local councils in the London area, which have expressed concern over the ways in which AUTOGUIDE will select and recommend routes in their areas of jurisdiction.

3.6 Automatic vehicle identification

AVI is the term used for techniques which uniquely identify vehicles as they pass specific points on the highway, without requiring any action by the driver or an observer. AVI systems [69] essentially comprise three functional elements: a vehicle-mounted transponder or tag; a roadside reader unit, with its associated antennas; and a computer system for the processing and storage of data. At the simplest level, information which identifies the vehicle is encoded onto the transponder. This normally consists of a unique identification number, but can also include other coded data. As the vehicle passes the reader site, the transponder is triggered to send the coded data via a receiving antenna to the roadside reader unit. Here, the data are checked for integrity before being transmitted to the computer system for processing and storage.

Two-way communication is also possible with some AVI systems. Here, data flow occurs in both directions, with coded messages being transmitted between the reader unit and vehicle-mounted transponders. More sophisticated technology is needed for this type of system, with additional capabilities required in both the roadside and vehicle-based equipment.

AVI can potentially contribute to relief of urban traffic congestion in a number of ways through its vehicle-roadside communications link. One of its potential applications lies in providing real-time travel speed information, which can then be utilized as an input to traffic information systems such as HAR, RDS or AMTICS. At the simplest level, a coded vehicle identification number can be passed from the vehicle to the roadside each time a reader unit is passed. This identification data can be processed by a central computer to obtain journey times between the various distributed reader units in an AVI network, giving an indication of traffic conditions between these points.

AVI systems with full two-way vehicle-roadside communication allow messages to be passed back from the roadside reader station to the vehicle. Vehicles could potentially be warned of congested areas, accidents or adverse weather conditions, enabling drivers to take alternative routes. The network condition information forming the basis of these messages would be derived by the central computer from journey time information computed from the AVI data passed from vehicles to the roadside.

A significant project currently running in the field of AVI is the HELP program. The \$19 million HELP program is funded and directed by a group of 14 states, as well as the Port Authority of New York and New Jersey, the federal government and

various motor carrier organizations. The aim of the program is to develop an integrated truck traffic information and management system combining AVI, weigh-in-motion and automatic vehicle classification technologies with a networked data communications and processing system, comprising roadside stations linked to regional and central computers [70, 71, 72].

AVI systems can be used to introduce traffic restraint policies aimed at reducing congestion levels. Road pricing is one approach to traffic restraint for which AVI is an ideal implementation tool. The theory of road pricing [73] is that road users should pay for their use of road space according to how much they are contributing to congestion. It therefore depends upon charging vehicles for being in a particular place at a particular time. AVI systems linked to a computer network can be used to set up toll sites on the highway network using AVI readers. Road user charges can be varied by time of day and location, according to congestion levels. Vehicles equipped with AVI transponders debit an account each time they cross a toll site, and are subsequently billed for their road usage.

AVI has been demonstrated for road pricing in Hong Kong on a trial basis, [74, 75] and has been shown to be technically feasible (Figure 3.7). However, there are significant issues of public acceptability concerned with using AVI for this purpose which need to be considered. First, traffic restraint policies in themselves tend to be controversial and unpopular with a significant proportion of the population. Second, use of AVI for road pricing requires that all vehicles which enter the congested area are fitted with an AVI transponder or "electronic license plate." This mandatory fitting of electronic license plates raises privacy objections which contribute to the difficulties of implementing AVI systems for this particular application.

Finally, AVI systems may alleviate congestion where they are utilized for automated toll collection. AVI-based automatic toll collection facilities have been under consideration for several years, with experiments carried out by the Port Authority of New York and New Jersey, Caltrans [76] and the Golden Gate Bridge Authority. An operational system is currently being implemented on the Dulles Toll Road in Virginia [77]. In this application, regular users of toll bridges, tunnels or turnpikes opt to have their vehicles fitted with AVI transponders, so that they do not need to stop to hand over cash when driving through the toll plaza. AVI fitted vehicles are automatically identified and the appropriate charges are calculated by a computer system. These are either automatically deducted from a prepaid account or users can be billed at regular intervals. Use of this type of system should increase the throughput of toll facilities, reducing the level of congestion at the toll plaza and on the approach roads.

A number of approaches to automatic vehicle identification have been developed since the first investigations of AVI were carried out in the 1960s. Recent advances in vehicle detection and data processing techniques have made the application of AVI systems both technically and economically feasible. AVI system can be divided into four main categories as described in the following paragraphs.

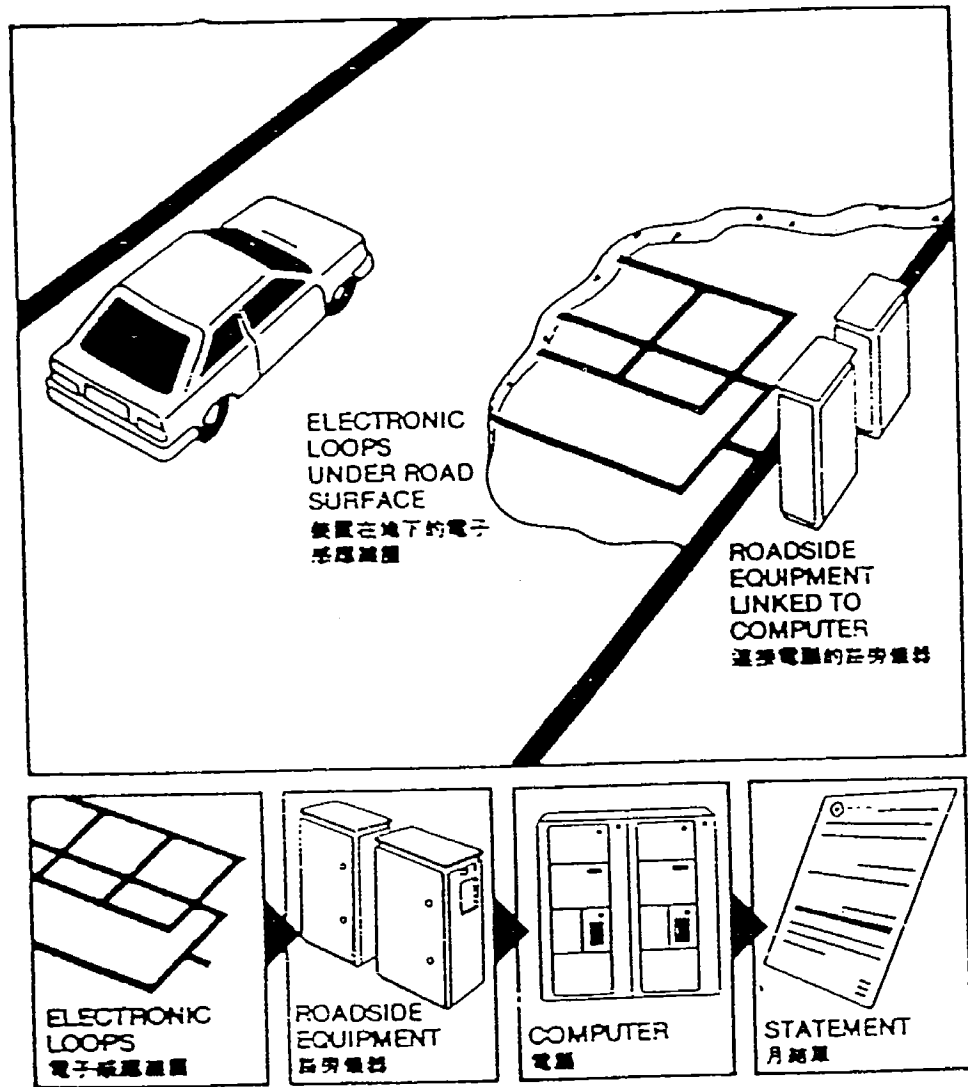

Figure 3.7 The Hong Kong electronic road pricing system
 (Source: Reference 74)

Optical systems formed the basis of the earliest AVI technologies developed in the 1960s in the U.S. and Europe. However, optical systems require clear visibility, performance being seriously degraded by snow, rain, ice, fog or dirt. They are also sensitive to reader/tag misalignment, focusing problems and depth of field limitations, though improvements in performance have been achieved in recent years. A recent project undertaken at the University of Arkansas carried out investigations into bar-code optical AVI systems. The results suggest that, even with modern technology, the level of reliability of optical AVI is too low for many highway transportation applications.

Infrared systems were tried during the 1970s as a substitute for the earlier optical approaches, but were found to share many of the problems of the earlier optical systems, being similarly sensitive to environmental conditions. AVI applications usually require very high read reliability levels and the fundamental nature of these problems is such that both optical and infra-red approaches have been largely abandoned by AVI manufacturers.

Inductive loop AVI systems use conventional traffic detection and counting loops in the highway pavement to detect signals from transponders mounted on the underside of vehicles. These approaches can be divided into active, semi-active and passive systems, according to the source of power used by the vehicle-mounted transponder.

Radio frequency (RF) and microwave systems generally utilize roadside mounted or in-pavement antennas, transmitting or receiving on a wide range of frequencies in the kHz, MHz and GHz ranges. These systems can also be divided into active, semi-active and passive approaches.

One advantage of microwave systems is that they can transmit data at much higher rates than inductive loop systems, as they operate at higher frequencies. However, a potentially serious problem associated with passive microwave systems concerns the power levels which must be transmitted in order to energize the vehicle-mounted tags. In many countries these may violate limitations on accepted safe operating levels for microwave systems. Semi-active systems offer a compromise, using a sealed unit transponder with an internal battery. These allow radiated power levels to be greatly reduced, while providing for a transponder design life of several years.

Surface acoustic wave (SAW) technology is the basis of another AVI approach [78, 79]. A SAW tag consists of two elements, an antenna and lithium niobate SAW chip that serves as a multi-tapped electronic delay line. The SAW chip receives an interrogating signal through the attached antenna, stores it long enough to allow other reflected environmental interference to die out and then returns a unique phase-encoded signal. The key operating characteristic of the SAW chip is the ability to convert the electromagnetic wave into a surface acoustic wave. SAW tags overcome concerns over high microwave power levels but are limited to purely fixed-code applications.

3.7 Summary

In summary, a range of systems is being developed and demonstrated which can provide drivers with information on highway conditions and route availability. Traveler information systems have potential to assist motorists in the three key activities of route planning, route following and trip chain sequencing. In particular, electronic route planning systems offer pretrip advice, potentially reducing the proven inefficiencies in driver route selection. New traffic information broadcasting techniques offer greatly increased coverage and selectivity, to alert drivers to ever-changing traffic situations. On-board navigation systems help drivers find and follow a preferred route, while externally-linked route guidance seeks to combine route choice with real-time response to congestion within a truly dynamic system.

4. ADVANCED TRAFFIC MANAGEMENT SYSTEMS

4.1 Introduction

Control of traffic in time as well as space adds a fourth dimension to traditional highway engineering solutions to the congestion problem. The coordination of road space and road time on a particular ramp or intersection can be extended to wide-area schemes capable of securing major traffic benefits at relatively modest cost. The proven benefits of traffic management include freer traffic flows, shorter journey times, substantial fuel savings, and generally reduced congestion. Because the benefits can be great, the use of these techniques is already widespread in the U.S. and overseas [80, 81, 82].

Operational objectives of ATMS include making the best use of existing highway network capacity and cutting journey times, without creating adverse environmental effects [83]. By reducing congestion and delay, some systems have been utilized to produce fuel savings or to reduce traffic noise and vehicle emissions. Linked with other systems, urban traffic control (UTC) can provide the basis for an expanded control philosophy incorporating features such as variable message signs, congestion monitoring, emergency vehicle priority and other intervention strategies. In the longer term, current techniques could be extended into areas such as expert system traffic control, and interaction with ATIS technologies such as the route guidance techniques described in the previous chapter [84, 85].

Traffic control systems can also be used to influence the pattern of route choice in pursuit of policy objectives such as protection of residential environments, increasing safety, assisting pedestrians or giving priority to transit vehicles. As well as being reduced, congestion can be redistributed between geographic areas or between categories of the highway system to arrange for queuing to take place in areas where it can best be accommodated. Warnings can be directed from traffic control centers through variable message signs or in-vehicle information systems to help prevent secondary accidents and to direct vehicles away from congested areas.

This chapter considers recent and ongoing developments in the field of ATMS. It includes fixed-time and traffic-responsive UTC strategies; incident detection techniques; freeway and corridor control systems; and future possibilities for interactive control, combining these techniques with those described in the previous chapter.

4.2 Traffic signalization

Traffic signals on urban highways allow vehicle movements to be controlled through time and space segregation, speed control and advisory messages. Signal equipment and control techniques have evolved to deal with a wide range of highway situations and traffic demands. This section considers how available

techniques might be better utilized, and goes on to examine some new and upcoming approaches with greater potential.

Coordination between adjacent traffic signals on arterials, ramps or grids requires some form of plan or strategy to integrate individual signal timings on a wide-area basis. Both fixed-time and traffic-responsive strategies of control have been developed and are now applied in urban areas in many parts of the world. Fixed time coordination is commonly utilized in most U.S. cities, while traffic responsive techniques are becoming more widespread in some other countries [86, 87].

Although advanced technologies may have much to offer in the field of traffic control, it is also worth considering what could be accomplished by better utilization of existing approaches. Techniques already exist for the determination of optimal signal timings at isolated intersections and in fixed-time coordinated networks. The hierarchy of signal timing systems can be divided into the following categories, each of which is discussed in subsequent paragraphs:

- * isolated intersection control;
- * fixed-time coordination;
- * partially-adaptive coordination;
- * fully-adaptive coordination; and
- * fourth generation systems.

Isolated intersection control systems may be operated fixed-time, semi-actuated or with full vehicle-actuation. Whichever strategy is used, there is often scope for improvements in signal timings to reduce delays. The very simplest methods derive green splits manually, in proportion to expected traffic demand. More complex methods calculate signal timings according to a predetermined performance measure and involve some form of computer optimization [88, 89, 90, 91, 92].

SOAP84 is a computer program developed for the FHWA and used for optimizing isolated intersection settings. The model calculates optimum cycle time and green splits based on a modified Webster's method [93, 94].

Current developments in isolated intersection control are looking toward advanced control strategies to replace current methods of vehicle actuation. MOVA (Modernized Optimized Vehicle Actuation) works on a principle of approach occupancy, and trades off stopping approaching vehicles against holding already-stopped vehicles for a few more seconds. Two sets of loops are used on each approach at distances of 130 feet and 330 feet from the stopline [95]. The LHOVA algorithm adopts a similar approach [96, 97].

Fixed-time coordination is another area where much could be achieved through the wider use of established techniques. In 1982 it was estimated that there were some 130,000 sets of traffic signals in the U.S. which formed some part of coordinated systems [98]. Cimento [99] described progress made during the 1960s

and 70s in bringing these systems under electronic computerized control (Figure 4.1).

The concept of coordination is to control the durations and offsets of green periods at adjacent sets of signals along an arterial or within a network. To maintain coordination from cycle to cycle, each intersection must operate with a common cycle time, or sometimes half the basic cycle. The green periods at each intersection are timed in relation to each other by specifying an offset for each set of signals, based on the average journey time along each link. The offset is the starting time of a specified phase, measured against a common time base of one cycle duration.

Coordinated signal timings for arterials were first produced manually using time and distance diagrams. In many areas, signal plans are calculated using computerized versions of the time and distance concept, typically providing maximum bandwidth "green wave" progression on limited numbers of arterials. Examples of computer programs for maximizing bandwidth and progression along arterials include MAXBAND [100] and PASSERII-84 [101].

For grid networks, one of the first, national initiatives to develop efficient fixed time coordinated traffic signal timings was the SIGOP program [102], produced in 1966 for the Bureau of Public Roads. The SIGOP optimization routine utilizes an algorithm which depends on two variables: ideal offset, calculated from speed, link length, and queue discharge time; and link weighting, which can either be specified as input data or calculated by SIGOP in proportion to the competing approach volume demands.

More recently, a different approach has been utilized for coordinating fixed-time signals, based on network optimization. The TRANSYT (Traffic Network Study Tool) program models traffic behavior, carries out an optimization process, and calculates the best signal settings for the network. The program also provides extensive information about the performance of the network including estimated delays, numbers of stops, journey speeds and fuel consumption. TRANSYT has been extensively documented and only a few references are quoted here [103, 104].

TRANSYT models traffic behavior using histograms to represent the arrival patterns of traffic. The histograms are called cyclic flow profiles [105] because they represent the average rate of traffic flow during one signal cycle (Figure 4.2). The signal optimizer searches systematically for a good fixed-time plan by minimizing a performance index such as the weighted sum of delays and stops on all links of the network. Specific links can be further weighted to give priority to HOVs or to guarantee green waves along arterials. Otherwise, TRANSYT seeks a global optimum, trading off the needs of arterials, side roads and grid sections of network to calculate efficient signal settings for the area as a whole.

One of the earliest evaluations of TRANSYT was performed in Glasgow, Scotland in 1968 [106]. TRANSYT was still in its developmental stages, and was compared with existing uncoordinated vehicle actuation. The results of the Glasgow trial showed an average 16 percent reduction in vehicle delays using the TRANSYT method, compared with the existing system. The maximum benefits were apparent during the morning and evening peak periods.

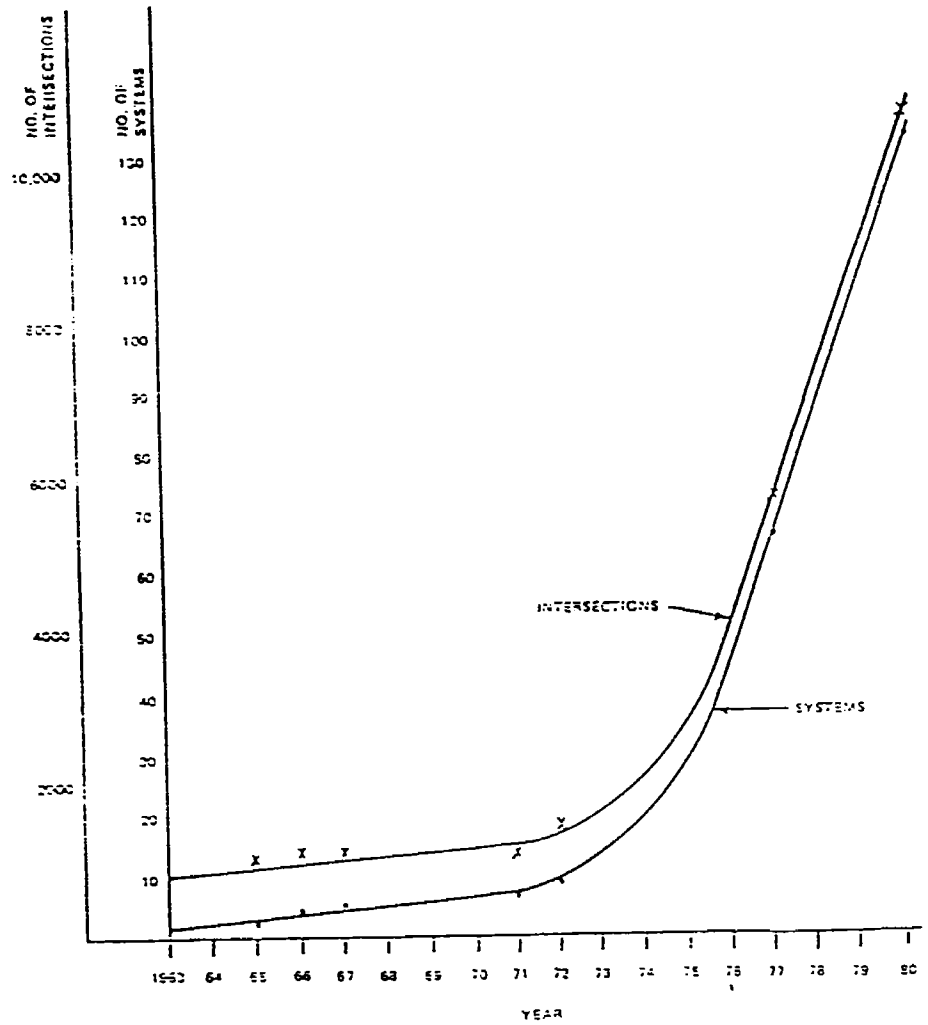

Figure 4.1 Number of computerized traffic control systems and controlled intersections in the U.S.
(Source: Reference 99)

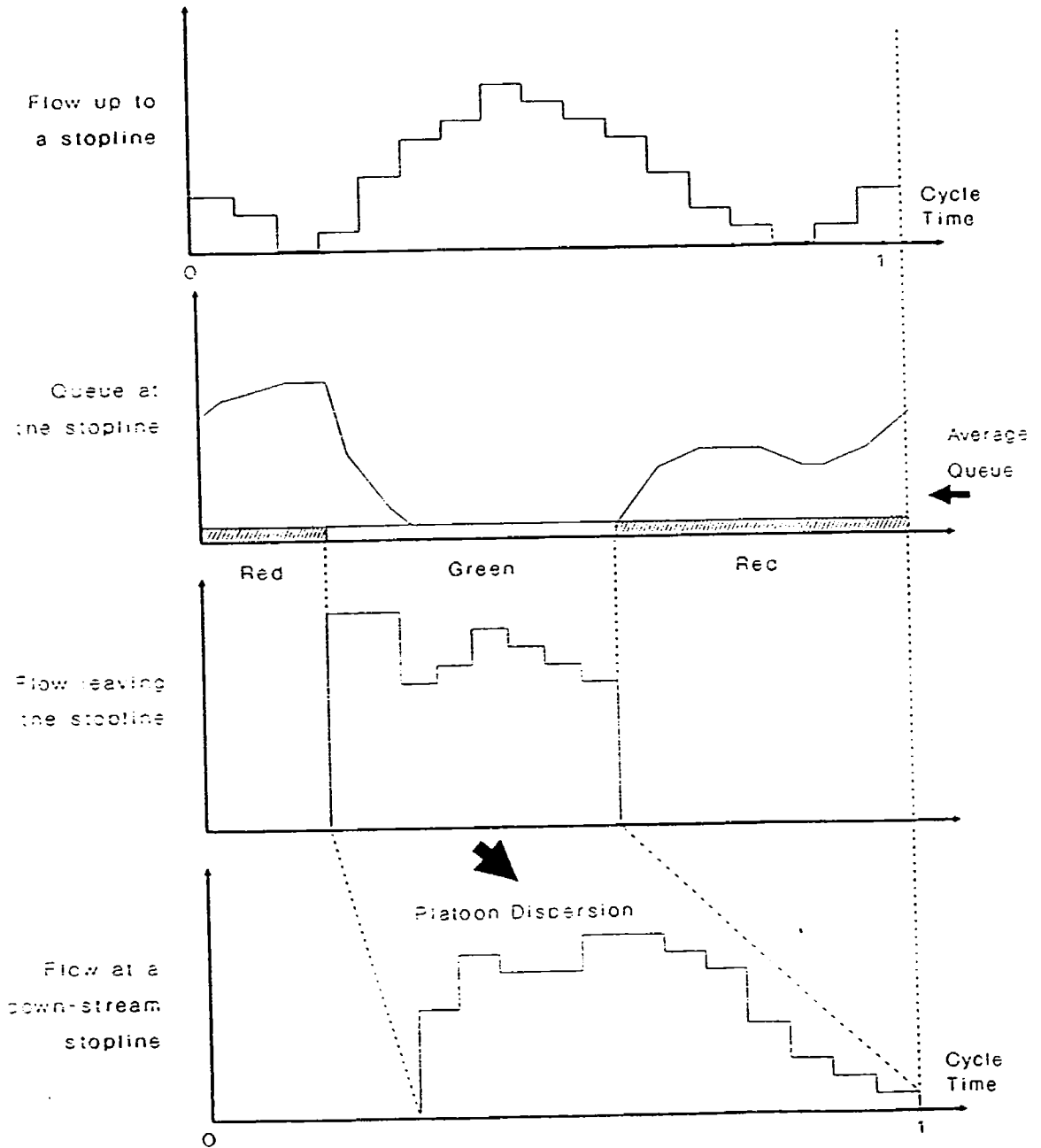

Figure 4.2 Cyclic flow profile in the TRANSYT model

(Source: Reference 104)

The current version of TRANSYT-7F was developed by the University of Florida Transportation Research Center, and evaluated in the NSTOP project [107, 108]. Since 1981, TRANSYT-7F has gone through five releases. Initially, a fuel consumption model was added to allow for optimization of energy usage. A Platoon Progression Diagram (PPD) capability was subsequently included, showing traffic densities at all points in time along links in a time-space diagram format. Release 5 now provides four new capabilities:

1. a gap acceptance model for permitted, opposed movements;
2. explicit treatment of "sneakers," who turn left at the end of a permitted phase;
3. explicit treatment of stop sign control; and
4. modeling of shared left and through lanes.

TRANSYT-7F has been widely evaluated and applied, in programs such as FETSIM [109, 110, 111, 112].

In Europe, also, enhancements to the TRANSYT program have continued, with two recent versions providing increases in capability. TRANSYT-8 included a fuel consumption model, explicit treatment of yield control, provision for modeling opposed turning movements, and inspection of a range of cycle lengths. More importantly, however, it incorporates a capacity-sensitive component in the performance index, limiting queue formation on short links by "gating" or metering traffic in the vicinity of critical intersections.

The recent TRANSYT-9 incorporates three further updates. These are:

1. an interactive editing program for creating and modifying data input files;
2. a routine allowing users to examine the effects of different phase sequences; and
3. an interactive program for demonstrating queue and performance index graphs for individual links over one complete cycle.

The benefits offered by any new fixed-time signal plan will depreciate over time as traffic conditions change and the plan becomes less appropriate. Experience shows that signal plans degrade by about 3 percent per year, so that the initial benefit can be lost within five years. Actual rates of ageing may vary significantly about this mean and will tend to be more acute in grids than along arterials [113].

The aging process arises from:

- * changes in traffic demands over the whole network;
- * changes in traffic flows on specific links due to rerouting or demand shifts; or

- * physical or regulatory alterations to the street network.

This aging process implies that retiming programs such as FETSIM need to be a permanent feature with all fixed-time signal coordination schemes. In practice, updates occur infrequently because of the time and costs involved, even though such actions would be highly cost-effective. It is to avoid these problems that traffic-responsive coordination systems have been developed. These systems are described below.

Partially-adaptive coordination approaches monitor traffic conditions in a network using some form of detection, and react to the information received by implementing appropriate signal settings. In other words, systems of this kind adapt themselves to traffic patterns and respond to traffic demands as they occur.

A good fixed-time system will typically require four to eight changes of plan during a normal weekday. In some cities, controller equipment permits only a single plan to be operated all day, while other systems allow only separate plans for morning peak, inter-peak and evening peak [114]. In more advanced systems, libraries of eight or ten alternative plans are normally prepared and switched in as required. Sometimes plan changes are carried out manually based on visual surveillance of traffic conditions using closed circuit television cameras (CCTV). However, the most common method is to change plans at particular times each day, determined historically in the light of expected traffic conditions.

The simplest form of traffic-adaptive system involves automated plan selection. In this method of control, the information received from on-street detectors at critical intersections is used to select the most appropriate signal plan from a predetermined library. Although this method provides a degree of self-adjustment to prevailing traffic conditions, it still requires the time-consuming preparation of signal plans off-line. Evaluations also suggest there is no convincing evidence that systems which select fixed-time plans on the basis of flows and congestion measurements perform any better than the simpler procedure of changing plans by time of day [106, 115].

The major U.S. initiative in this area was undertaken within the Urban Traffic Control System (UTCS) project initiated by the FHWA. The first generation UTCS control system began operating in 1972 at a test facility in Washington, D.C. In this system, detector data were used automatically on-line to select appropriate cycles, splits and offsets.

The first generation software used prestored timing plans developed off-line, based on previously generated traffic data. Plan selection options included manual, time-of-day and automated plan selection based on recent volume and occupancy data. The results of the UTCS-1 test in Washington, D.C. showed improvements over previous control systems. Within the test, the traffic responsive strategy of automated plan selection showed small, but generally significant benefits over alternatives such as time-of-day selection. A further test in New Orleans showed larger benefits overall for UTCS-1 relative to previous equipment. However, in this case time-of-day was marginally ahead of automated plan selection.

At the present time, generation 1.5 UTC systems represent a step toward traffic-responsive approaches, potentially replacing wholly fixed-time operation. Work on the development and implementation of generation 1.5 concepts can be seen in the ATSAC (Automatic Traffic Signal and Control) system implemented in Los Angeles [116]. In the ATSAC system, enhanced UTC equipment utilizes loop detectors for flow monitoring to identify when signal plan changes are required. Off-line plan development is also partially automated, based on data from the on-street detectors.

Development of a second generation UTCS strategy was also undertaken. This approach represented a real-time, on-line system that computes and implements signal timing plans based on surveillance data and predicted changes. UTCS-2 retained many features of the first generation system. However, UTCS-2 results showed network-wide degradation in performance in every instance relative to the base case three-dial system. Increases in delay ranged from 1.1 percent to 9.3 percent with the worst results occurring during the evening peak period. Slight improvements (2 percent) were measured on the arterial portion of the network, but it is unclear whether these gains were statistically significant.

The lack of success of the earlier second generation vehicle-responsive systems led to investigation of the reasons for failure. Some of the problems of this adaptive systems approach are believed to be [117]:

- * **Frequent plan changing.** Most of the second generation methods of control required that new plans be calculated on-line and implemented as soon as possible. Even the best methods of plan-changing cause significant transition delay and so a new plan must operate for more than 10 minutes to achieve an overall benefit.
- * **Inadequate prediction.** From the above it is seen that a prediction for several minutes into the future is necessary. Random variations in traffic make this prediction very difficult. Historical data may be needed to help identify trends.
- * **Slow response.** When unexpected events occur, the response is delayed by the historical element of prediction and the need for a new plan.
- * **Effects of poor decisions.** Unexpected events or faulty detector data may cause poor plans to be implemented which cannot be corrected until the next plan update.

The SCATS system, developed and initially implemented in Sydney, Australia, is said to overcome the problems identified with early second-generation systems [118]. SCATS combines several features of UTCS-1 and 2, using background traffic control plans selected in response to traffic demand. Signal timings within these plans are determined according to traffic conditions at critical intersections which control coordination within small subsystems.

The subsystems vary in size from one to ten intersections and, as far as possible, are chosen to be traffic entities which can run without relation to each other. As traffic demands increase, the subsystems coordinate with adjacent subsystems to form larger groupings. This 'marriage' and 'divorce' of sub-

systems is calculated using simple empirical rules based on traffic flows and intersection spacings.

Each subsystem requires a substantial database, including minimum, maximum and geometrically optimum cycle lengths, phase split maxima and offset times. Background plans are stored in the database for each subsystem. Cycle length and the appropriate background plan are selected independently to meet the traffic demand, using data from stop line detectors at critical intersections. Empirical relationships are used to decide whether the current cycle and plan should remain or be changed.

At peak periods, SCATS determines subsystem cycle lengths according to traffic demands at critical intersections, using Webster's method. Offsets are pre-calculated to suit the busier direction of travel. Progression is not guaranteed in the less busy direction at peak times [119]. During off-peak periods, SCATS selects the minimum of two or three precalculated cycle times giving good two-way time-distance progression [120].

Fully-adaptive coordination approaches represent a goal sought by researchers in several countries throughout the 1970s. In the U.S. work on UCTS-3 was designed to create a fully responsive, on-line traffic control system.

UCTS-3 [121] utilized two optimization algorithms: an approach with no fixed cycle times, for under-saturated conditions, and congested intersection control/queue management control for use along congestion paths. In the former approach, signal coordination was accomplished by implementing a coarse simulation of traffic flow, and then systematically adjusting signal settings to minimize a weighted sum of delays and stops. The congestion algorithm aimed to maximize throughput and manage queue lengths to avoid blocking adjacent intersections.

Results of a UCTS-3 evaluation in Washington, D.C. showed increases in delay ranging from 3.4 percent to 15.2 percent relative to the base case three-dial system. Overall, the third generation system produced about 10 percent more delay than the previous system utilized in Washington, D.C.

In Europe a coordinated, fully responsive traffic control strategy was developed by the U.K. TRRL. The system is called SCOOT, an acronym for Split, Cycle and Offset Optimization Technique. This system was developed in association with three electronics companies - GEC, Plessey and Ferranti, who now market the software. SCOOT reacts automatically to changes in traffic flow, adjusting the cycle time, the splits, and the offsets in accordance with an on-line optimization process.

SCOOT monitors cyclic flow profiles in real time for input to a TRANSYT-type optimization. The vehicle detectors are inductive loops, located well upstream of each intersection, usually close to the preceding signal (Figure 4.3). SCOOT uses this information to recalculate its traffic model predictions every few seconds and makes systematic trial alterations to current signal settings, gradually implementing those alterations which the traffic model predicts will be beneficial. The principles of the SCOOT traffic model are illustrated in Figure 4.4.

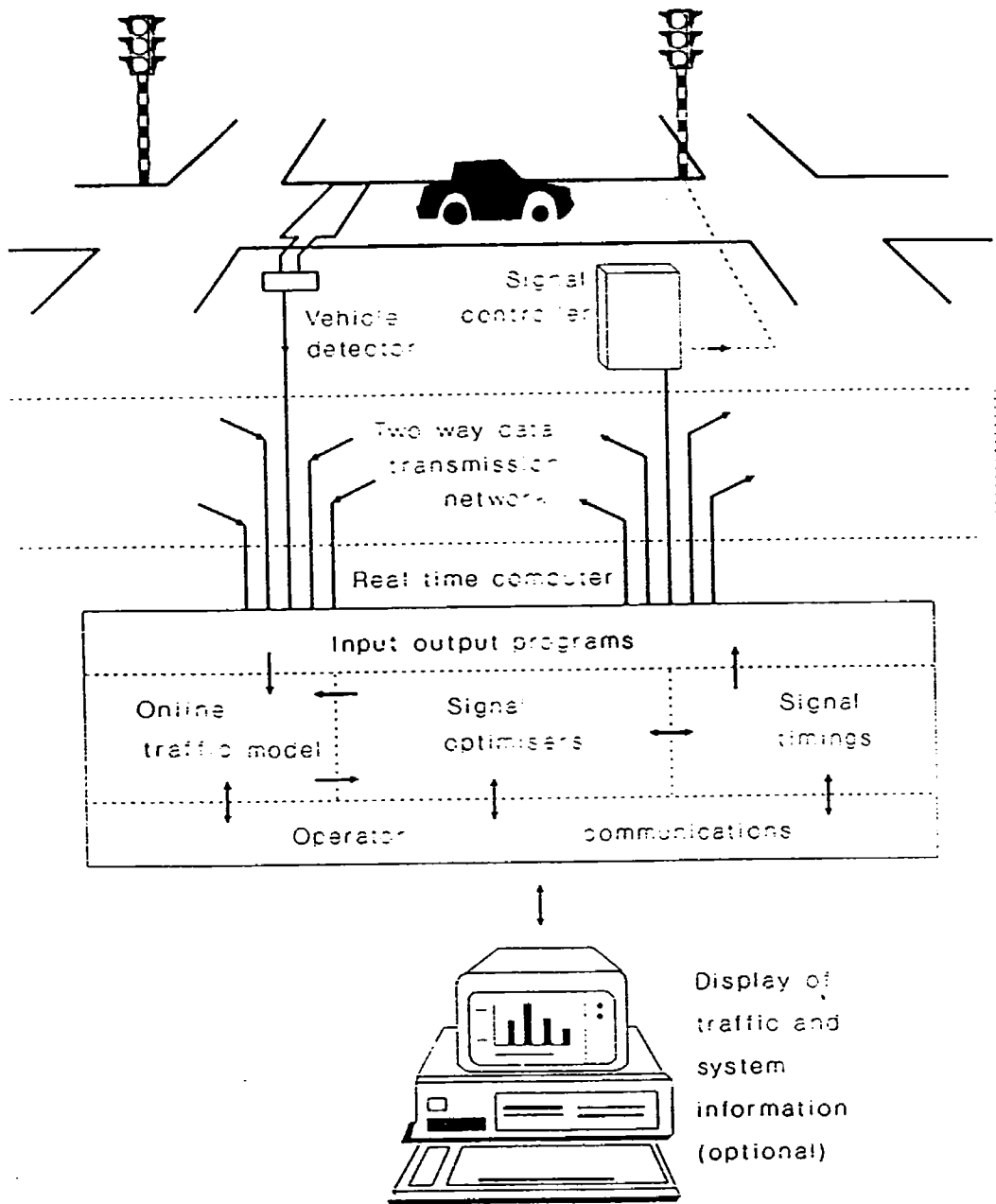

Figure 4.3 Flow of information in the SCOOT system

(Source: Reference 121)

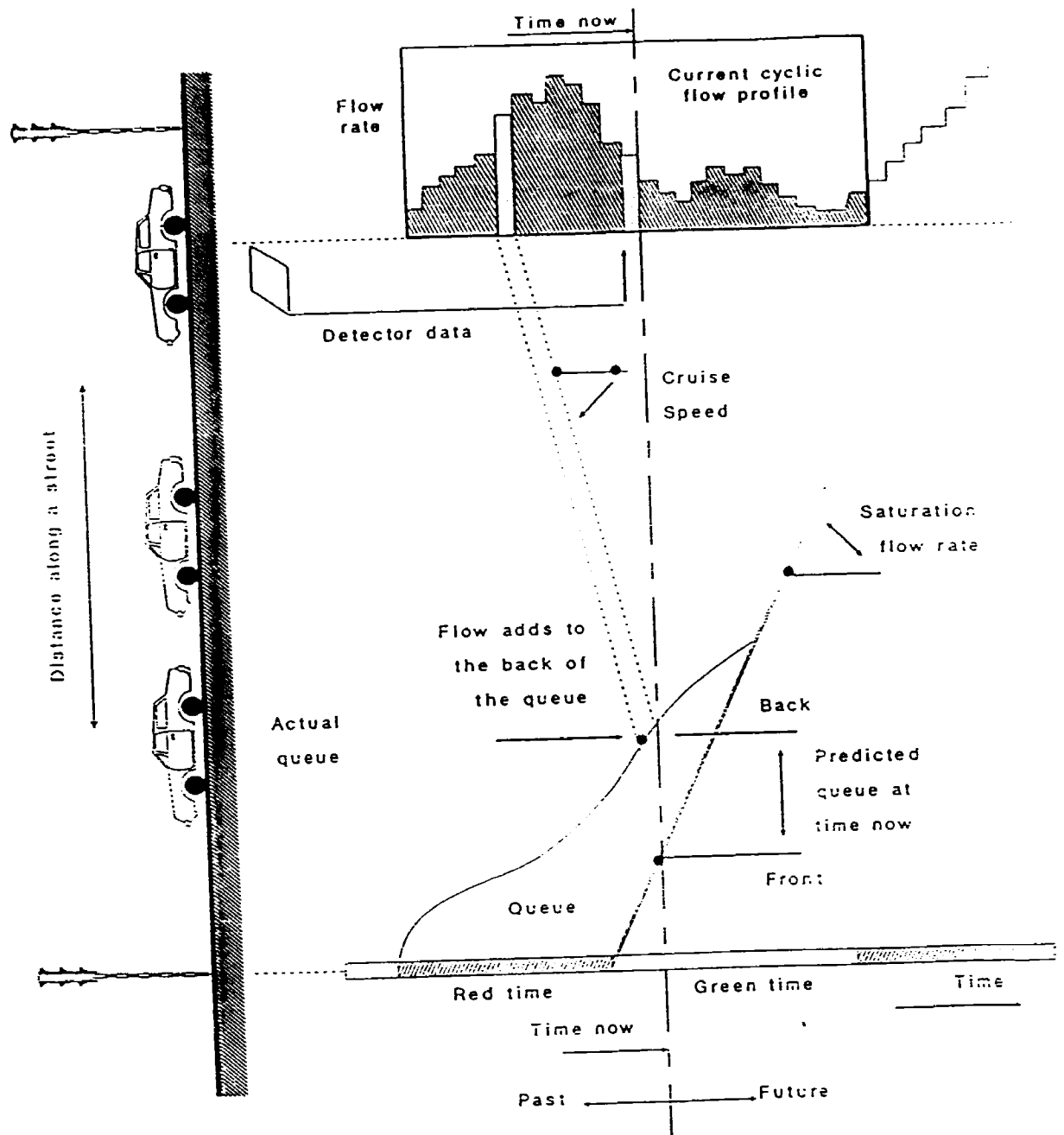

Figure 4.4 Principles of the SCOOT traffic model
 (Source: Reference 121)

The first trials of fully adaptive control were carried out in 1975 [121], at the end of an initial research and development phase. These encouraged the U.K. Department of Transport to develop the system for general use. Further research by TRRL led to an improved system which was evaluated in Glasgow during Spring 1979. SCOOT was compared with up-to-date, carefully optimized fixed-time TRANSYT plans. Both in this evaluation, and in subsequent trials in other cities, SCOOT has consistently improved upon fixed-time TRANSYT control by significant margins.

Research suggests that adaptive control is also likely to achieve an extra 3 percent reduction in delay each year, relative to fixed time control, as fixed time plans age and become less appropriate for current traffic flows [113]. Over the four to five years between TRANSYT updates typically occurring in well-maintained systems, this would accumulate to an extra 12 to 15 percent. In many instances, where fixed time plan updates are less frequent, the benefits of a traffic-responsive system could be larger.

Fourth generation systems represent the highest level of signal control complexity considered within this review. Systems such as SCOOT do not represent the end of the line in traffic control strategies, and are in a very real sense already 15-year old technology. Some of the limitations of SCOOT-type approaches which need to be addressed by future fourth generation systems include:

- 1) The current policy of minimizing transients and allowing only "creeping" plan changes is beneficial in maintaining coordination but mitigates against the objective of fast response when conditions change rapidly, for example due to an incident. A fourth generation system would decide when to kick in a remedial plan, which the system would then fine tune using an incremental optimization.
- 2) While TRANSYT's heuristic optimization technique is normally specified to try both large and small step sizes within the process of seeking a global optimum, incremental changes as well as limitations on processing power inherently restrict the scope of SCOOT to an essentially local optimization. Field evaluation shows that this is not a major problem. However, a fourth generation system should be able to take occasional large steps to radically new plans, subject always to an evaluation of the disruption resulting against the eventual benefit.
- 3) By monitoring cyclic flow profiles at the beginning of each link, and necessarily smoothing out random fluctuations in traffic flow, SCOOT effectively , for recently past traffic conditions, rather than the upcoming situation. The amount of lag differs in respect of split, offset and cycle. A fourth generation system would contain subsystems for short-term forecasting, based initially on historical data and real-time origin-destination estimation, and perhaps later on feedback from externally-linked route guidance systems.
- 4) The loop detectors utilized by third generation technology give only limited information on network traffic conditions. Externally-linked route guidance systems offer much greater feedback on signal plan

performance, in the form of actual journey times and delays as they occur.

- 5) While in many ways, the second generation SCATS system is a tool no better than the engineers who set it up, SCOOT's use of an on-line traffic model makes it into a black box you either love or hate. Recent development of SCOOT "procedures" has led to traffic management techniques which work essentially by fooling the model. A fourth generation system would contain explicit, policy-related intervention strategies for use by highway agencies, or by a higher-level expert system.

Table 4.1 summarizes the advantages and disadvantages of current approaches to UTC. Traffic adaptive systems are more costly to install than purely fixed time systems. However, the additional benefits demonstrated by advanced systems can justify the cost within a short period. In the short-term, fixed-time and responsive systems can operate signals in adjacent parts of urban areas. Adaptive systems may give greatest returns in CBDs where congestion is high and flow patterns are complex, varying from day-to-day. Fixed time control will work well where congestion is lower and flow patterns more consistent.

4.3 Incident detection systems

Another category of advanced technology systems included in this review is that of automatic incident detection systems. Incidents such as accidents or queue formation behind slow-moving vehicles can rapidly cause significant congestion problems, particularly on freeways. Techniques are now becoming available which will automatically detect incidents, allowing adjustments to be made to traffic control strategies and enabling information to be passed to drivers through many other technologies.

Traffic incidents can generally be divided into recurrent and nonrecurrent problems. Recurrent problems occur routinely during peak periods when traffic demand exceeds capacity, even for relatively short time periods. Peak-period congestion occurs daily and is reasonably predictable in both effect and duration. Nonrecurrent problems are caused by random, unpredictable incidents such as traffic accidents, temporary freeway blockages, maintenance operations, oversize loads, etc. Environmental problems such as rain, ice, snow and fog also fall into this category [122, 123].

Automatic incident detection systems typically consist of a small computer or distributed microprocessor system, monitoring signals from vehicle detectors spaced along the highway. Special algorithms are used to detect incidents by looking for particular disturbances in traffic flow patterns.

A number of operational automatic incident detection systems have been implemented in the U.S. The most important of these is in use on the Chicago freeway system. In the Chicago area, loop detectors are provided in each lane every three miles along the freeway. Flow is also sampled in one of the center lanes at half-mile intermediate points. All ramps are monitored to produce a

Type of UTC system	Advantages	Disadvantages
Fixed time	<ul style="list-style-type: none"> * Cheaper to install and maintain. * Can be implemented using non-centrally controlled equipment. * Familiarity with settings for regular users. * 'Green waves' easily implemented. 	<ul style="list-style-type: none"> * Needs large amounts of data to be collected and updated. * Signal plans will require updating. * Disruption of plan changing. * Requires operator reaction to incidents. * Cannot deal with short-term fluctuations in flow levels.
Partially adaptive	<ul style="list-style-type: none"> * Can deal with some day-to-day fluctuations. * Plan change time may be more appropriate. * Might be valuable on arterial routes. * May be cheaper than fully responsive control as fewer detectors required. 	<ul style="list-style-type: none"> * Requires as much or more data to be collected as for fixed time systems. * Detector failure possible. * Needs decisions on thresholds for plan change. * May plan change for wrong reason. * Difficult to foresee all plan needs.
Fully adaptive	<ul style="list-style-type: none"> * Less data need to be collected in advance. * Plan evolves so avoids problems with plan changing and updating. * Can deal with short and long-term fluctuations in flow levels. * Automatic reaction to incidents. * Monitors traffic situation throughout the area. 	<ul style="list-style-type: none"> * Detector failure possible. * More expensive to install. * Requires central control. * Maintenance critical.

Table 4.1 Summary of the advantages and disadvantages of different types of UTC systems

closed subsystem every three miles. The actual field location of detectors usually depends upon the availability of utility service, often most readily available around urban interchange areas. All surveillance and control points in a particular service area are brought to a roadside cabinet, through aerial or underground interconnect systems [124]. These are connected in turn to a surveillance center.

In Europe, different algorithms have been developed for incident detection. HIOCC, for example, operates by identifying the presence of stationary or slow-moving vehicles over individual induction loop sensors. This is achieved by looking for several consecutive seconds of high loop occupancy. An alarm is initiated when this is detected.

In the U.K., an experimental incident detection system was initially installed on the M1 and M4 motorways. Seven monitoring loops were cut into the pavement surface at intervals of 1600 feet, and preliminary investigations enabled improvements to be made in the system [125]. Based on these trials, a commercial system based on HIOCC is now available from the Golden River Corporation known as GRID (Golden River Incident Detection) [126] (Figure 4.5). Since these initial developments, the scheme has been extended to cover 50 miles of the congested M1 motorway [127] (Figure 4.6).

In West Germany, incident detection equipment has been used to alert motorists of the formation of queues at an autobahn bottleneck [7]. Inductive loop detectors are used to record traffic volume and vehicle speed data for analysis at a control center. If the traffic data reveal that a performance threshold has been passed, an automatic queue warning is given to approaching vehicles via variable message signs, and successively lower speed limits are set. This gradually reduces the speed of traffic nearing the queue, decreasing the danger of rear-end collisions.

Systems for detecting adverse environmental conditions are a second type of automatic incident detection system, which could also potentially be linked into a computerized monitoring network. There are a number of commercial sensor systems available, such as those manufactured by SCAN of St. Louis, SFG in West Germany and ELIN Electronics in Austria [128, 129, 130].

The most significant implementation of an integrated system to date has taken place on the Dutch freeway system. Here electronic roadside sensors that automatically detect dangerous road conditions likely to cause accidents and congestion were installed in 1985 (Figure 4.7). These are capable of remotely detecting pavement slickness due to rain, snow, ice, sleet or commodity spillages. Variable message signing is linked to the sensors to direct drivers to slow down as necessary [132, 133, 134].

Another operational example of the use of incident detection to warn of adverse environmental conditions is in West Germany, where fog warning systems have been installed at several locations [7]. These are used on autobahns where fog occurs frequently and rapidly, often over localized areas. The equipment uses sensors to continuously measure the range of visibility. This information is relayed to a control center and compared with a threshold. Where poor visibility is detected, the roadside variable message signs and hazard warning lights are

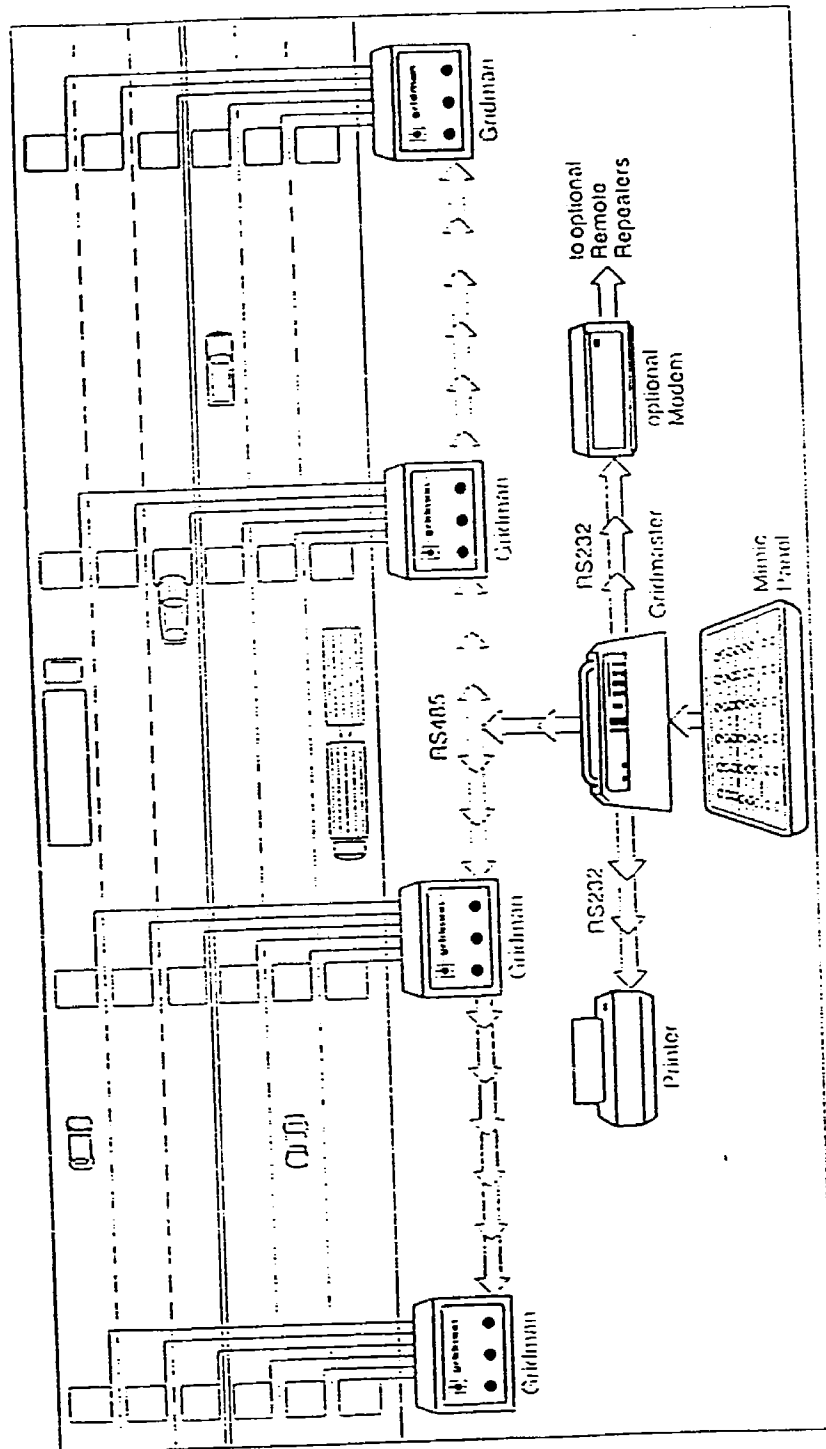

Figure 4.5 Grid incident detection system

(Source: Reference 126)

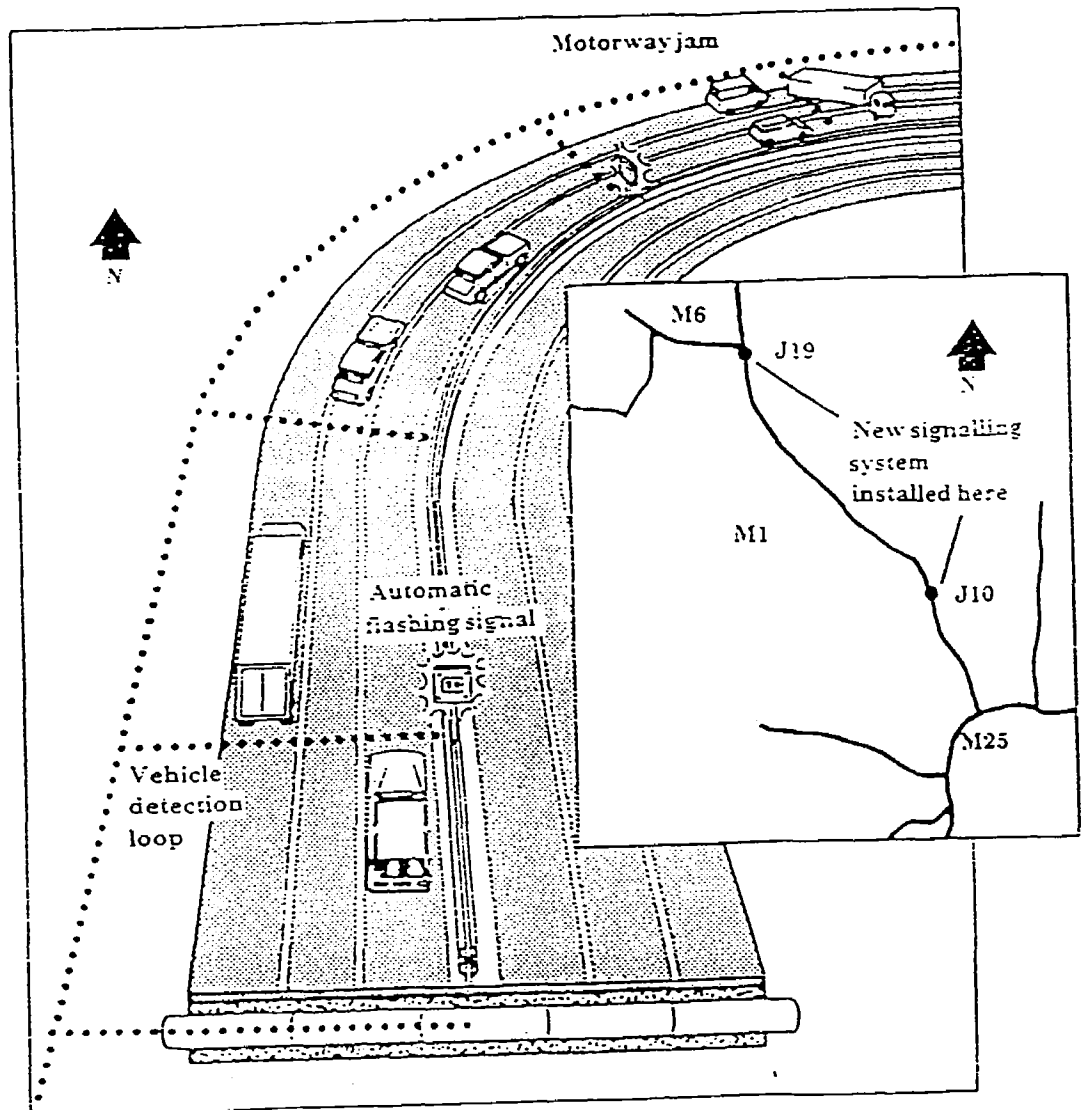

Figure 4.6 Incident detection system, M1 motorway
 (Source: Reference 127)

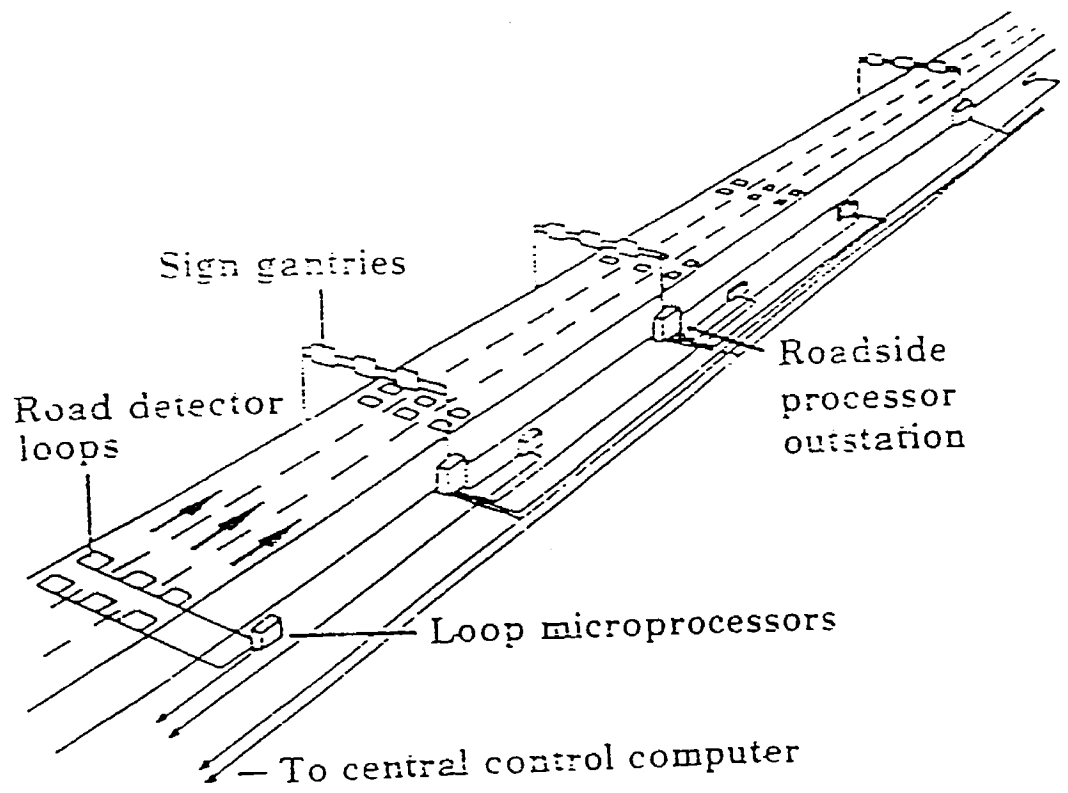

Figure 4.7 Rotterdam's motorway control and signalling system
 (Source: Reference 131)

activated as a means of providing advance warning. Variable message signs are also used to display successively lower speed limits on the approach to the affected area.

4.4 Freeway and corridor control

Freeway management techniques fall into two main categories: capacity management and demand management [135]. Capacity management seeks to maximize throughput and improve the level of service, while demand management attempts to reduce the vehicle miles traveled or encourage off-peak travel. Examples of capacity management include ramp closures, ramp metering, variable speed control, lane control, express or reversible lanes, etc. Demand management techniques include staggered or flexible working hours, ridesharing, and improved public transit.

Ramp control aims to limit the rate at which vehicles enter the freeway, in order to avoid overloading the facility. Ramp closures are the simplest and most drastic form of ramp control. However, because of public opposition, ramp closures are not widely used in the U.S. [136, 137], though they are routine in Japan [138, 139].

Ramp metering [140] is more widely utilized, and may have greater potential for interfacing with advanced traffic control technologies. A standard traffic signal is used to control entry to the mainline. In the U.S., a single vehicle is commonly released per green, while in Europe, operation resembles conventional signals with longer green and red periods. Chicago was the first metropolitan area to practice ramp control in 1963 [141]. Ramp metering signals now control traffic at 91 locations along various Chicago-area expressways. Centrally timed by the traffic systems center computer at Oak Park, the ramp signals are varied continuously as measured ramp and mainline flows are monitored in real time. The total instrumented network covers 110 highway miles, with 1650 loop detectors.

Evaluations of ramp metering in Chicago found that the technique reduced peak period congestion by up to 60 percent and accidents by up to 18 percent [142]. Benefits will vary according to the level of congestion prevailing before the implementation of controls [143]. On Houston's Gulf Freeway, for example, travel times were reduced by 25 percent and accidents by 50 percent, with little adverse effect on adjacent arterials. Many other North American cities report favorable experiences from implementing ramp control [144, 145, 146, 147].

Ramp metering has also been experimentally implemented on the M4 motorway in Birmingham, U.K. A signal control algorithm responds to speed and flow data received from detectors located on the ramp and in the motorway lanes. Capacity downstream of the intersection is monitored continuously to allow metering rates to be adjusted in line with current conditions. The system is activated automatically in response to traffic conditions and remains in operation throughout the morning peak. Traffic on the ramp is given a green signal unless the combined ramp and motorway demand flow exceeds a critical limit, or traffic speeds at the intersection fall below a preset threshold.

Mainline control of speeds using variable message signs has been implemented in Britain, the Netherlands, Germany, Italy, Japan and the U.S. Speed advisories can be used to give advance warnings of traffic incidents or fog ahead. In Holland, they are also used to help smooth peak traffic flows. Elsewhere, they have been less successful as a capacity-enhancement measure; drivers in both Britain and the U.S. commonly ignore advisory speed limits [148, 149, 150].

Lane reversal for tidal flow operation is implemented both on freeways and arterials in many countries. In the U.S., reversible lanes are often indicated by permanent signs and lane markings alone, relying on drivers to observe time-of-day limitations. In Europe, variable message signs are almost always used for permanent tidal flow control, with overhead gantries and advanced warning signs which are electronically switched at the appropriate times.

Traffic control centers are a vital requirement for integrating advanced technologies to improve conditions on urban freeways. Washington State Department of Transportation, for example, has had a freeway control center in operation for over 10 years. This is capable of monitoring flows, through a system of traffic detectors and data links. Virginia Department of Transportation (VDOT) also has a freeway control and monitoring system in operation. The Traffic Management System (TMS) is a computerized freeway surveillance and control system that monitors and regulates traffic flow along Interstate 395 and Interstate 66. Traffic flow data is gathered by 550 traffic counters imbedded in the pavement of interstate lanes and entrance ramps. Current mainline traffic and incoming demand are balanced with the known capacity of the freeway using ramp metering. The VDOT system also includes variable message signing for communicating with drivers.

Typical European practice in control center and communications design, including closed circuit television, emergency telephone and radio systems, signalling, and maps has been set out in a U.K. Home Office publication [151]. British freeways are controlled from five regional computer centers over the National Motorway Communications System (NMCS-2), which links emergency telephones every mile and variable message signs at least every two miles. Traffic speeds and flows are continuously recorded and meteorological conditions monitored from roadside outstations [152].

Corridor control is a concept which seeks to treat urban freeways and adjacent arterials as a single system. The purpose of corridor control is to optimize the use of corridor capacity by diverting traffic from overloaded links to those with excess capacity. Currently, several corridor control projects are being developed, tested and evaluated [145, 153, 154, 155].

4.5 Interactive signal coordination

Interactive signal coordination is a new concept which may constitute the next generation of traffic control systems. It would go further than adaptive traffic control, in that it would be fully responsive to the actual pattern of short-term future travel demand, and would integrate traffic control systems with other advanced technologies. For example, an interactive system could be linked with

real-time traffic monitoring, short-term forecasting and electronic route guidance. Using data on actual vehicle destinations, it would then simultaneously optimize signal coordination and vehicle route choice within the urban highway network.

Interactive signal coordination is still at the stage where ideas and concepts are being synthesized. Therefore, a definitive concept for an interactive traffic control system has not yet been developed. However, a series of possible aims has been identified, including:

- * Minimize vehicle delays;
- * Minimize passenger delays;
- * Minimize variability in transit times;
- * Minimize user costs;
- * Minimize negative environmental impacts;
- * Minimize unnecessary travel; and
- * Maximize safety of the system.

In order to accomplish these objectives and address the shortcomings of existing control systems, a series of features that could be included in the fourth generation traffic control systems have been proposed. These include:

- * Integration of traffic signal control systems with other advanced systems, leading to coordinated control of a number of different systems.
- * Prompt detection of and response to events.
- * Ability to predict and respond to origin-destination information.
- * Integration with vehicle location, identification, and classification systems.
- * Inclusion of artificial intelligence and expert system features.
- * Accommodation of demand control and congestion pricing options.
- * Flexibility to accommodate different control objectives in different parts of an urban area or during different time periods.
- * Real time communications with motorists.
- * Inclusion of visual surveillance.
- * Variable speed control to determine appropriate speeds during periods of congestion and inclement weather.

- * Provisions for integration with automatic vehicle control.

4.6 Summary

Advanced traffic control systems are further developed than the information technologies reviewed in the previous chapter. Control of traffic in time as well as space adds a fourth dimension to conventional highway engineering solutions to the congestion problem. The proven benefits of these systems include freer traffic flows, shorter journey times, substantial fuel savings, and generally reduced congestion.

Signalization strategies include improved methods of isolated intersection controls and fixed time coordination; partially and fully adaptive coordination; and new concepts for fourth generation, expert systems control. Incident detection systems may in future be integrated with other advanced traffic control techniques, within freeway corridors and in due course throughout entire metropolitan areas. Finally, interactive traffic control concepts seek to integrate the driver information systems discussed in Chapter 3 with the traffic control systems of this chapter.

5. ADVANCED VEHICLE CONTROL SYSTEMS

5.1 Introduction

AVCS can help drivers to perform certain vehicle control functions, and may eventually relieve the driver of some or all of the control tasks. The use of AVCS technologies is likely to result in greater safety, more consistent driver behavior and improved traffic flow characteristics.

Vehicle control is complex because of the large number of interactions which exist between the driver and the vehicle. The driver's key roles can be defined as:

- * to observe the outside environment, including highway geometry, vehicles and obstructions;
- * to operate the vehicle's control system;
- * to feedback observations and compensate for changing situations; and
- * to make decisions and select an appropriate trajectory ahead.

On a journey a driver is constantly required to assess vehicular lateral position, speed, distance to vehicles ahead and judge gaps for merging and passing. Additionally, the driver must also anticipate the actions of other road users and make decisions on opportunities for getting through lane changes, merges, and intersections by achieving smooth braking and acceleration.

At the most basic level, AVCS can provide the driver with useful information and warnings, based on data collected by onboard sensors. The next stage is to assist the driver with the control process, by automatically adjusting the control system characteristics to the operating conditions and helping to avoid situations which give rise to loss of control. The third level is to allow the control system to intervene and manage critical situations. The highest level is for the system to completely take over the driving tasks.

This chapter provides an overview of AVCS concepts. It examines the AVCS technologies currently available, and considers the more widespread uses of these systems in the future. It outlines the systems which are presently under development and considers the feasibility of implementation of these technologies.

5.2 Antilock braking systems

The Antilock Braking System (ABS) assumes control of the braking function during periods of excessive braking or cornering. ABS differentially pumps the brakes to ensure rapid, nonskid braking. This is performed by a solenoid valve unit

which connects the master cylinder and the wheel cylinder, and is controlled by an electronic control unit.

To the driver, the benefit of ABS is the ability to remain in full control of the vehicle under every type of road condition and during emergency stops. Without ABS, once the front wheels lock in an emergency stop it becomes impossible to steer the car. Similarly if the rear wheels lock, the car becomes unstable and is prone to skidding. Wheel lock also reduces the effect of the braking action. There are several proprietary antilock braking systems now available, such as those marketed by Scania [156] and Alfred Teves [157].

The widespread implementation of ABS could reduce the number of accidents involving skidding. According to one survey, 13.5 percent of all injury accidents involve some form of skidding [158]. Investigations suggest that over 7 percent of all road accidents might have been prevented if ABS had been fitted to the vehicles involved [157].

Another technology that can be incorporated with ABS is Electronic Traction Control (ETC), also known as slip-spin control. This utilizes the same sensors and computer that prevent the wheels from skidding during braking to prevent the wheels from slipping during acceleration.

When a vehicle is accelerating on a surface with a low coefficient of friction, opening the throttle too wide will cause the wheels to spin. The wheels are then no longer able to transmit lateral force, causing the vehicle to become unstable. Using ETC, sensors detect when the wheels are about to start spinning, and prevent this from happening by reducing engine torque or partially applying the brakes.

5.3 Speed control systems

Speed control systems are an essential component of AVCS technology. Two types of speed control systems are available on present generations of vehicles. These are cruise control and governors.

Cruise control [159] is one form of speed control technology that is already in widespread use in the U.S. In normal operation, the cruise control maintains the speed of the car, set by the driver, until a new speed is selected or the brake pedal depressed. The cruise control can also permit controlled acceleration and deceleration, and can resume to a speed stored in the memory following a braking incident.

The European PROMETHEUS program is currently examining the feasibility of developing cruise control systems capable of responding to external vehicle sensing devices. This concept, called "Intelligent Cruise Control," aims to develop techniques to process sensory information for the control of vehicle speed [160]. In the most sophisticated form, it may be feasible to interpret sensor information on road and traffic conditions, speed of other vehicles, obstacle detection and forward visibility and to adjust the speed accordingly. Preliminary research indicates that a prototype system capable of operating in

a well-structured environment could be demonstrated in the near term, given required progress with sensor technology research.

A second speed control technology already available, though not widely utilized, is the speed governor. Governors are limiting devices which prevent a vehicle from exceeding a preset speed limit. They have mainly been used on heavier vehicles, such as trucks and buses, powered by diesel engines. When the vehicle exceeds the preprogrammed speed, a signal is triggered which acts on the fuel injection pump to prevent further acceleration.

5.4 Variable speed control

A natural extension of current speed control systems would be variable speed control (VSC), for which the component technologies largely exist. Systems which vary vehicular speed automatically or provide the driver with information for optimal speed adjustment have the potential to reduce speed differentials and minimize the frequency of vehicle stops.

The simplest form of VSC would program conventional cruise controls or governors with mandatory fixed speed limit information appropriate to each section of highway. This could be readily accomplished using existing AVI technology described in Chapter 3. Another option is to locate reference markers such as electronic chips or small permanent magnets at variable spacings in the traffic lane so as to indicate safe speed by marker spacing.

In a second stage of application, variable-message speed control signs similar to those widely utilized on European freeways could be linked by AVI to an onboard VSC. Equipped vehicles would automatically select the safe operating speed for each section of highway, which could be optimized to suit capacity considerations or lowered under adverse weather conditions.

The aim of VSC at traffic signals would be to assist the driver in selecting a suitable speed on the approach to an intersection so that the vehicle would not need to stop. Advisory roadside speed control signs have been utilized for many years in West German traffic control systems, informing drivers of the optimal cruise speed to reach the next signal at green.

More recent research in West Germany has led to the development of an in-vehicle speed advisory system at traffic signals [7]. Infrared beacons installed at intersections are used to transmit signal timing information to approaching vehicles equipped with a suitable onboard receiver. The recommended speed is indicated by green light points which are integrated within a conventional speedometer. The system has been developed and tested jointly by Volkswagen and Siemens, and is currently being investigated further as part of the PROMETHEUS program.

Each of the three applications of VSC outlined in this section could be operated in an advisory mode or an automatic mode linked to cruise or governor systems controlling the vehicle's throttle setting. The automatic mode could be user-selectable, allowing drivers to override the system, or could be mandatory.

requiring vehicles to comply at all times. The mode of operation could also be varied on different types of highway, so that mandatory speed control might be required for drivers to be allowed to use certain high-capacity, limited-access facilities comparable to current HOV lanes.

5.5 Automatic headway control

A natural extension to intelligent cruise and variable speed controls is the addition of sensors to automatically maintain a constant headway or gap between vehicles. The essential elements of an automatic headway control (AHC) system are a distance monitoring system, signal processing, control logic and speed regulation through throttle and brake control. The block diagram in Figure 5.1, from a paper by Grimes and Jones [161], shows a radar headway control system based on cruise control technology. When fitted with an AHC device, a vehicle would automatically slow when approaching a vehicle, and remain at a safe distance until such time as it was appropriate to resume the original cruise speed. This feature would be particularly useful for urban freeway driving.

Papers by Hahn [162] and Belohoubek [163] concentrated on AHC system with automatic throttle control only. Belohoubek describes a system which utilizes a microprocessor to monitor ground speed and radar signals reflected from the vehicle in front. Throttle control is achieved by means of a linear DC motor connected by a chain, which receives instructions from the microprocessor in the form of variable-width pulses. The system does not incorporate automatic brake control, deceleration being achieved by air friction and engine drag when the throttle is released. If more rapid deceleration is required, an audible warning advises the driver to brake manually.

The European PROMETHEUS program has defined several relevant research topics within the AHC area. Lissel [164] outlines the development of a headway control distance sensor to enable drivers to maintain a safe driving distance in front of the vehicle. Cloup [165] describes another research topic within PROMETHEUS to analyze and interpret sensor outputs for an anticollision radar. The objective is to calculate the relative speed and distance of the object and, using the vehicle's speed, to determine the likelihood of a collision. The output can then be fed to a decision system for appropriate action to be taken.

PROMETHEUS has also defined a research project aimed at improving the reliability of radar sensors [166]. The project will involve the use of a video camera as well as a radar system to enable headways to be deduced. Another project within PROMETHEUS is outlined by Bray [167]. The aim is to determine and track the presence of a leading vehicle, using a pair of stereo cameras. Similar developments aimed at vehicle steering using existing roadway lane markings are also understood to have begun recently within the Texas state IVHS program.

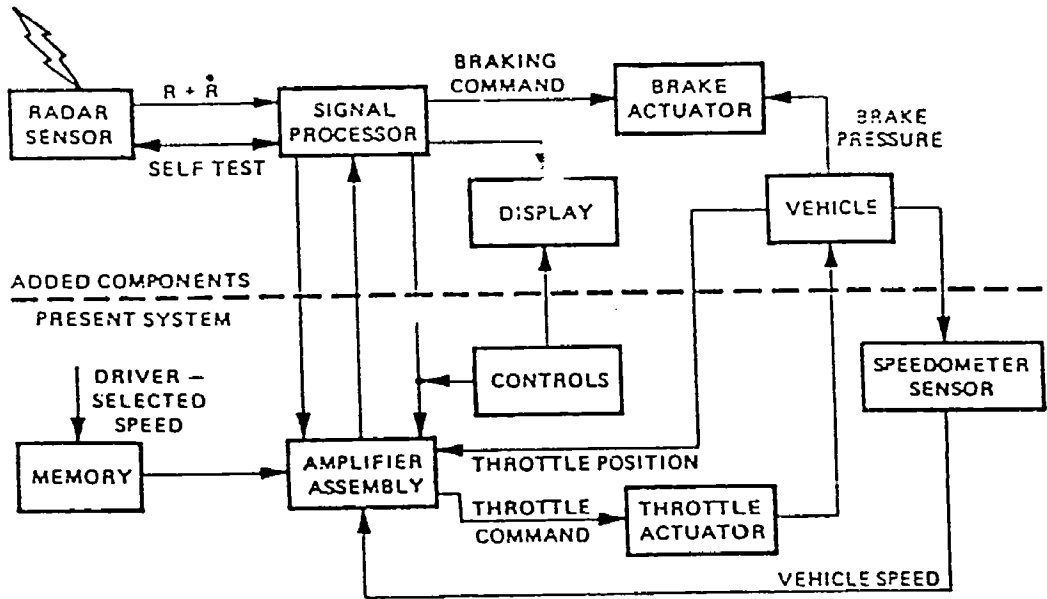

Figure 5.1 Block diagram of an AHC system
(Source: Reference 161)

5.6 Collision warning systems

The major cause of collisions, on all types of highway, results from an inability of some drivers to correctly judge speeds and distances. This is especially true in bad weather conditions and at night. A system which warns drivers that they are driving too fast or too close, or, in the event of an impending collision, automatically applies the brakes, could significantly reduce this type of accident, and provide an associated reduction in congestion.

One such collision avoidance system that has been extensively investigated is automatic braking using radar detection. Brinton [168] describes an early system which used doppler radar. Further work has been carried out in this area by researchers such as Flannery [169], Troll [170], and Grimes and Jones [161].

Radar braking operates by detecting the presence of an obstacle in front of the vehicle, such as another vehicle or a pedestrian, using a radar head fitted to the front of the vehicle. From these raw data, a signal processor calculates the range and relative velocity of the vehicle and the object. Various processing techniques have been developed to perform this function. Long-range radars use one of two methods for range calculations; pulse modulation or frequency modulation. Short-range radars can also use these techniques, or may alternatively be based on the duplex Doppler method or sinusoidal frequency modulation.

Having received and analyzed the range and relative velocity, the signal processor is fed further data relating to the vehicle's ground speed and the present state of braking. This is analyzed and compared with the range and relative velocity. The processor utilizes internal logic to decide if the target is real or false and, in the event of a collision being deemed probable, actuates the brakes.

One of the main problems of radar braking is false alarms. False alarms may be caused by roadside obstacles, such as trees, signs, fences or parked cars, or by vehicles in different lanes or traveling in different directions. Obstructions in the roadway must be separated into major items and inconsequential items. Systems are particularly vulnerable to false alarms at corners or bends, where a roadside obstacle or vehicle may appear to be in line with the direction of travel. This problem may be reduced by limiting the range of the radar, although this also reduces efficiency at high speeds.

Another major problem with radar braking is that of 'blinding'. This occurs when radar signals from vehicles traveling in the opposite direction block out the return signals from potential obstacles. There are also certain problems associated with radar braking systems caused by poor weather conditions, with the most serious problem being backscatter from rainwater.

While a number of manufacturers and researchers have worked on radar braking, the problems described above have led many of these efforts to be abandoned. However, a radar-based collision avoidance system that may represent the state-of-the-art in this area is currently being tested in California as part of the PATH initiative [171]. The system has been developed by Radar Control Systems

Corporation, and responds to changes in the speed of a moving vehicle ahead of the equipped car. A radar antenna mounted on the front of the vehicle broadcasts a low power radar signal which is reflected back from the leading vehicle. An in-vehicle unit processes the signal and detects whether the speed of the leading vehicle is changing. Where hazards are detected, the driver is advised to reduce speed using a warning voice or head-up display. The system can also include an override function to automatically brake the vehicle when required.

Another type of radar-based collision avoidance system developed in the U.S. is GM Delco's Near Obstacle Detection System (NODS) [171]. This uses microwave radar and continuous Doppler technology to detect objects within an area behind the vehicle. Future versions of the system will also include side and blind spot obstacle detection. GM's research laboratories are additionally working on a project known as the Highway Driver's Assistant (HDA). The HDA vehicle integrates AVCS technologies such as lane sensing, hazard warning and headway control with navigation, route planning and real-time traffic information facilities.

5.7 Automatic steering control

Automatic steering control (ASC) systems linked to power assisted steering can ensure vehicles follow a predetermined path along dedicated highway lanes. Automatic steering control systems must possess three essential constituents:

1. A roadway reference system, which can be sensed by a vehicle in order to ascertain its lateral position relative to the highway.
2. Onboard sensors which measure the lateral displacement and determine any necessary remedial action.
3. A steering control system which acts automatically on command signals to maintain or adjust the lateral position as required.

Techniques for achieving lateral position control can be categorized into two groups: those systems which require passive roadway reference systems, and those using active reference systems.

A passive reference is an inert structure or component of the guideway, such as a metalized strip, painted stripe, passive reflectors, or a sidewall. Each vehicle obtains its own positional information using onboard equipment to detect this inert reference. One particular type of passive system that has been considered by Mayhan and Bishel [172] utilizes radar and a reference system in the form of a fixed barrier at the side of the roadway to obtain the necessary information for lateral control.

An active reference is used in the second type of ASC system to provide the information required for lateral position control. This typically involves the use of an energized cable running along the desired vehicular path, usually buried below the pavement surface.

During the late 1950s, General Motors and RCA developed and demonstrated automatic control of steering and longitudinal spacing of automobiles [173] for what was called the "Electronic Highway." By 1962, the first university research on automatic steering control of automobiles was reported from Ohio State University [174], under the sponsorship of the Ohio Department of Highways and the Bureau of Public Roads. This led to a later, long-term control study, under the sponsorship of the Ohio Department of Transportation and the Federal Highway Administration between 1965 and 1980. The first broad-scale investigation of the application of automation technologies to urban transportation problems appears to have been in the M.I.T. Project METRAN, in the spring of 1966 [175].

The basis of this type of system was that a buried energized cable created a magnetic field which was sensed by equipment under the vehicle [176]. Deviations from the cable centerline produced a positive or negative dc error signal, depending on the direction, which was approximately proportional to the lateral displacement (Figure 5.2). The error signal was fed into a stabilizing circuit and the resulting signal used to operate the vehicle's steering.

A major problem with energized wire reference following systems is that of interference on reinforced concrete pavements, where steel reinforcement causes the magnetic field to be weakened and distorted. This leads to a disturbed ride, and in extreme cases could result in a total loss of lateral control.

5.8 Automated highway system

This final section deals with the most complex and ambitious form of AVCS: the automated highway system (AHS). The previous technologies assisted or assumed the role of the driver in performing one particular function, such as steering or braking. On an automated highway, however, vehicles would be totally automated in all aspects of control by a combination of these technologies, suitably adapted to an environment of total vehicle control.

The basis of the AHS is essentially vehicle control in two directions - longitudinal and lateral [177]. Incorporated with this must be an ability to merge streams of vehicles, allowing vehicles to enter and exit the AHS at appropriate intersections, as well as providing for breakdown and emergency facilities.

Two approaches for achieving longitudinal control have been advocated: synchronous, or asynchronous. The synchronous concept, also referred to as synchronous longitudinal guidance (SLG) or point-following, may be compared to a conveyor belt, divided into equal slots [184]. Each controlled vehicle is assigned a slot, and obtains reference information in order to determine its position relative to that slot. Reference information may be provided by one of two methods: either through the use of roadway or roadside position reference benchmarks, or through the use of a continuous signal moving at synchronous speed.

The asynchronous technique, sometimes referred to as the car-following approach, does not confine a vehicle to a moving slot, but rather controls a vehicle on the

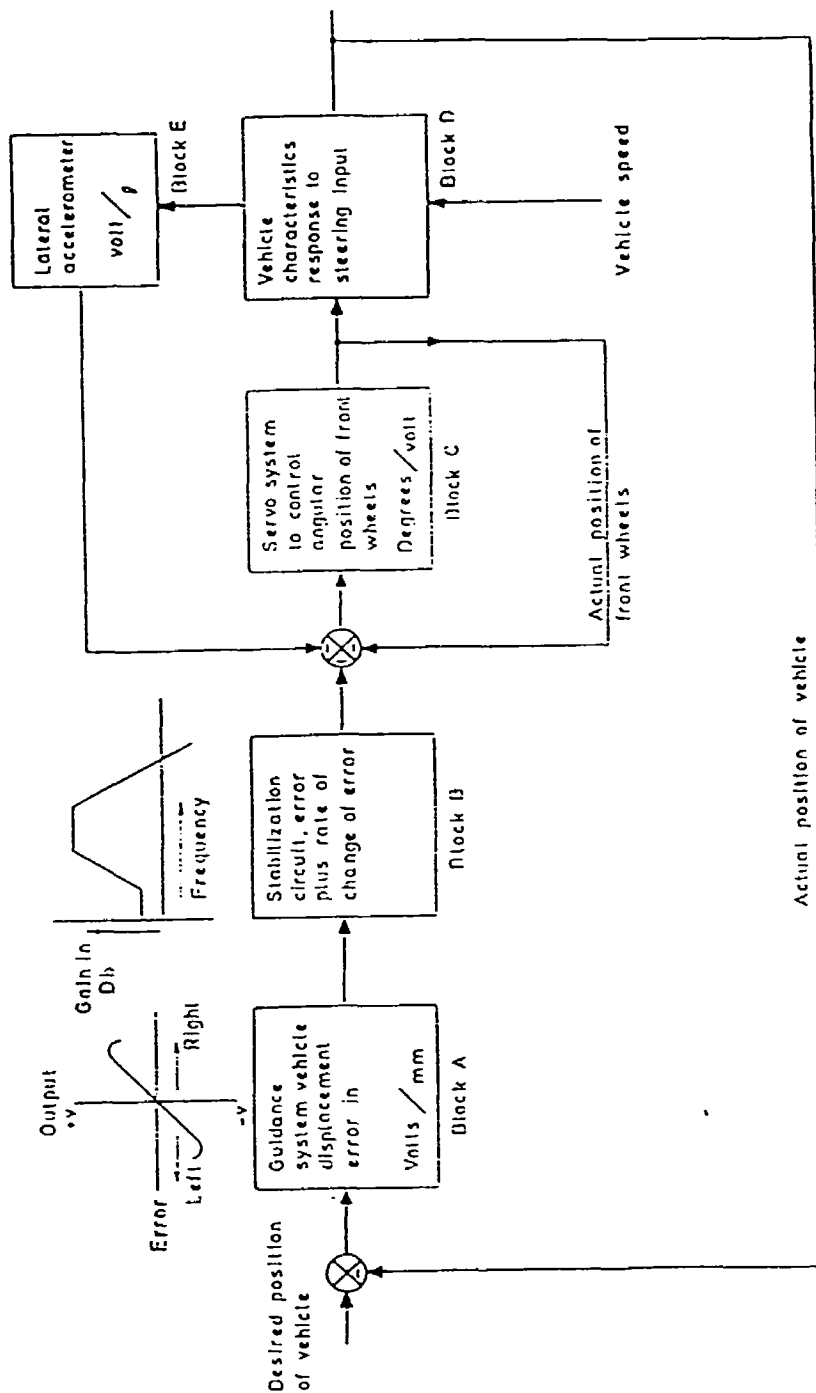

Figure 5.2 Operating principle of steering control system
 (Source: Reference 176)

basis of its state and that of the other traffic [179]. An example of the asynchronous concept, in which the control of a following vehicle is determined with respect to a leading vehicle only, is the use of AHC.

Although basic lateral and longitudinal control systems constitute the essential elements of an AHS, equally important is the ability to successfully merge vehicles into a controlled traffic situation. This might be achieved using the lateral and longitudinal control systems, and has two major aspects: the macroscopic or systems aspect, and the microscopic aspect.

The macroscopic aspect is concerned with the simultaneous merging of a large number of vehicles at many intersections, and the resulting effects on system performance. The microscopic aspect is concerned with the control of a particular vehicle during an automated merging maneuver.

Another important consideration is the control of vehicles entering and exiting the automated stretches of highway. An entering vehicle would be operated in the manual mode on the approach to the AHS, until the entry point was reached. The vehicle would then be merged into a suitable gap and would continue under automatic control. Exiting the AHS would occur in the reverse fashion, with manual control being restored during the final stage of the exiting procedure.

Given the substantial alterations necessary to the present vehicle population and roadway infrastructure, rapid implementation of a full AHS may not currently be practical. A more promising approach could be a staged implementation in which total automation would be achieved following the introduction of several less radical changes. While implementation is gradually taking place, vehicles both equipped and unequipped with the new technologies would still use the same highways. This "evolutionary" approach could essentially consist of three stages of deployment.

The first stage of the implementation would be the development and introduction of driver aids on a commercial basis. These would generally be vehicle-borne systems, requiring little or no support from roadside equipment. Several automobile manufacturers have already produced concept cars which incorporate collision avoidance radar. Metzler et al. [180] described the features included in the Mercedes-Benz research vehicle in 1981. Ford's Continental Concept 100 in 1984 also incorporated a sonar detection system [181].

After a testing period, there may be sufficient acceptance or demand to permit the introduction of the second stage. This would involve the phased introduction of subsystems for partial automation. The adaptation of an existing highway lane in each direction, for example, could allow the introduction of ASC. Suitably equipped vehicles would now be able to utilize steering control in the modified lane, whereas those not equipped would still be able to use the other lanes.

Eventually, given the successful execution of stages one and two, there could come a time when most vehicles are fitted with automatic longitudinal and lateral control facilities. When this is the case, the third stage, the phased introduction of fully automated highways, could begin. This would be the most radical step of the implementation process, requiring major development and construction of control center systems and intervehicle communications.

One recently advocated approach that could ultimately lead to full automation through a staged implementation process is the advanced vehicle command and control system (AVCCS) concept [182]. An AVCCS would combine a number of technologies that are either already in use or currently under development. The primary components of the AVCCS are a distance measurement and direction sensing system, a radar-proximity detection system and a cellular communications system. Each of these elements could be introduced independently to provide valuable benefits, implying that full automation need not be achieved through one major step with its associated risks and uncertainties.

The AVCCS concept is based around a passive transponder technology which will be embedded at intervals in the pavement surface. This will provide vehicle-mounted receivers with information on location, heading and the distance to the next transponder. The transponders will also transmit maximum vehicle speed, minimum headway and other data that may be required by the onboard unit. Between transponders, the AVCCS will use a wheel sensor and magnetic compass for vehicle control, supported by the radar proximity detection system. This latter technology will monitor all four sides of the vehicle, with a moveable detector on the front of the vehicle to track the rotation of the steering wheel.

The AVCCS concept has been designed such that the system could operate on current vehicle chassis and frame technology, requiring no alteration for the system to be fully functional. However, some alterations would be required to integrate the command and control system, to interface with the braking and steering, and to incorporate a route guidance capability. The degree of control provided by the AVCCS would be dependent upon the roadway's functional classification. On local streets, for example, only the navigation and collision avoidance functions would operate, while full automation would operate on limited access highways.

5.9 Summary

AVCS technologies seek to assist drivers in performing some or all of the driving tasks. Widespread use of AVCS could result in greater safety, more consistent behavior and improved traffic flow characteristics. At the most basic levels, AVCS can provide the driver with useful information and warnings. The next stage is to assist the driver directly, helping to avoid potentially dangerous situations. The third level would provide for system intervention through emergencies, while the final level would completely take over the driving task. Though AVCS are least developed of the IVHS technologies, their potential for relieving urban traffic congestion and improving rural safety could be very high.

6. FLEET MANAGEMENT AND CONTROL SYSTEMS

6.1 Introduction

The category of FMCS incorporates a range of technologies that are used to improve the efficiency, safety and convenience of vehicle fleet operations. Some of these technologies have already been described in this report in the context of their application to individual vehicles. This chapter therefore focuses on their application to fleet operations, including the following:

- * commercial vehicle fleets;
- * transit vehicles;
- * police and emergency service vehicles;
- * airport landside vehicles; and
- * taxicabs.

The chapter is divided into a number of sections, covering a range of FMCS functions and services. One approach that can be used to improve fleet operations is the application of computer software for operations design and planning. Software packages have been widely used to optimize transit services, providing increased convenience for users of the facility, and more efficient use of resources for the operating authority. Advanced technologies can also provide an important input to fleet management activities, by collecting various data to support operational planning.

FMCS can additionally be used to provide more immediate feedback on vehicle fleets to a central control point. This can permit a fleet supervisor to initiate control strategies to ensure optimum fleet performance. Technologies that can be used to provide this real-time monitoring facility include automatic vehicle identification, automatic vehicle location and automatic vehicle monitoring systems.

Another category of FMCS technology is dispatching systems. These have been widely applied for taxicab operations, and can also assist package delivery firms or emergency vehicles. The remainder of this chapter covers some of the main FMCS approaches and outlines examples of their use.

6.2 Operations software

One category of advanced technologies that can improve vehicle fleet performance is computer software. This has been substantially used by the transit industry in a variety of applications. Computerized systems have also been used to assist commercial vehicle fleet operations.

The optimization of transit services to ensure a combination of maximum efficiency for the operator and convenience for passengers requires careful consideration of several operational factors. In recent years, this has led to the development and widespread application of computer software packages for transit operations design and planning [183]. Principal applications of these packages include the following:

- * network and operations planning;
- * vehicle and crew scheduling;
- * marketing; and
- * management and administration.

Network and operations planning software is used to assist transit managers to develop new or revised networks and to evaluate the effects of proposed actions. Some packages develop optimum routes and vehicle frequencies, based upon passenger travel data gathered by the transit operator. An alternative to this approach involves the use of software packages to assess networks developed manually. These generally assign passengers to routes of prespecified trial networks, based upon the level of service of each route.

Scheduling packages are used by transit operators to determine the optimum times for vehicles to run on defined networks. These utilize passenger travel data, and typically operate in one of two ways. In North America, schedule calculations usually aim to achieve an equal number of passengers in every vehicle. This results in a set of vehicle departure times with intervals that change gradually as demand varies. In other countries, vehicles operate with fixed schedules, though additional vehicles may be used during peak periods.

Marketing aspects of transit operations software can include a number of desirable features. Software can be used to support an on-line interactive route inquiry service to assist in optimum passenger route selection. Material can also be produced for display at boarding points, outlining vehicle routes and times and recommending routes to alternative locations. In addition, software can be used to develop a format for travel directories to be distributed in the local community.

A final important element of transit operations software is management and administration facilities. These can assist transit operating authorities in the production of a wide range of documents, including correspondence, contracts, manuals, technical specifications and reports. Accounting activities can also be substantially supported using computer software packages.

In the area of commercial vehicle operations, one of the principal applications of computerized systems is in route planning and scheduling. In Europe, two systems in this area developed specifically for commercial vehicles are INTAKT and Routefinder [7]. INTAKT is a German computer program which provides route planning facilities for motor carrier vehicles. The system evaluates alternative routes between a specified origin and destination according to traffic conditions

at the time of travel. The special needs of commercial vehicles are also considered in the route selection process.

Routing information from INTAKT is available to motor carriers through a videotext system operated by the German telecommunications authority. The service is available to any user who possesses the appropriate terminal apparatus and has access to a telephone line. The system is widely used by the German motor carrier industry for the purposes of route planning, monitoring travel times and verifying reported mileage.

An alternative approach toward commercial vehicle routing is demonstrated by the Routefinder system, currently available in the U.K. Routefinder is a microcomputer-based software package which identifies the optimum route between two or more locations. It is generally used as a scheduling tool by fleet operators, as well as providing a customer services feature for car rental firms. In addition, Routefinder contains an audit function for assessment of sales force performance or other relevant indicators. The database for the U.K. road network is stored on disk and must be updated biannually to reflect alterations in the network.

6.3 Onboard computers and smart cards

Recent advances in microprocessor technology have led to the introduction of computers in cars, trucks and public transit vehicles. These have been used to monitor vehicle and driver behavior, and to assist the driver in performing the driving function in an economical and safe manner.

Onboard computers are also being increasingly used to improve the efficiency of vehicle fleet operations. These include express courier, taxi, public transit vehicle fleets, and truck fleet operations. Onboard computers for fleet management (sometimes referred to as vehicle management systems or VMS) generally comprise a computer linked to a number of electronic sensors. These are attached to various vehicle components to provide information on vehicle performance and driver behavior. Information from the sensors is converted to digital form and can be stored in memory by the computer, together with time and date information from an internal clock.

Onboard computers may also have a facility for the input of parameters by the driver. Currently this facility usually consists of a simple keyboard. However, developing voice recognition technology may also be applicable in this area.

A number of vehicle management systems are currently available, varying in capabilities and cost. These range from simple tachographs through taximeters to full computer-based management systems. Typical examples of each type of system are described in the following paragraphs.

The tachograph is an instrument designed to indicate driving time, speed and distance covered by the vehicle. The information is recorded on a special chart against a time scale by means of several styluses. The charts produced can be examined to obtain information about driver and vehicle activities. Generally,

this examination must be performed manually, although software is available which can interpret the data collected. Analysis of tachographs is therefore time consuming and often inaccurate.

Taximeters, originally developed to calculate taxi fares, have been advanced using new technology to measure and record many vehicle and driver characteristics. The latest taximeters are now capable of monitoring distance, time, speed, fuel consumption, engine revolutions per minute and other operating variables.

There are many different manufacturers of taximeters, producing a wide range of devices from the basic "traditional" taximeter up to the "vehicle supervisor system" capable of monitoring fleet operations. Some of the fleet systems are radio-based, with information on the status of the vehicle transmitted to a central location whenever the radio is set to talk mode.

Computer-based vehicle management systems represent the highest level of current technology. A wide range of vehicle management systems are currently available, varying in levels of sophistication and cost. Typical vehicle parameters monitored by the systems include engine revolutions per minute, speed, total trip miles, ignition on/off, water temperature and oil pressure. Information is fed continuously from the sensors to the computer, as illustrated in Figure 6.1. Some systems make provision for manually entering additional information such as fuel purchases or other expenses.

A principal use of onboard computers, in the context of fleet management, is for data collection. In this application, information is collected, stored and downloaded to a control center. It is then generally used to compile historical records which give an indication of driver and vehicle performance, for example:

- * Reports showing vehicle speeding, excessive idling periods, etc., for individual vehicle or driver trips.
- * Summary reports, giving details of vehicle utilization and driver productivity, for example.
- * Database reports, giving life-cycle equipment and operating information. These are useful at many levels, enabling maintenance effectiveness to be determined, manpower and equipment needs to be assessed, and long-term fleet performance to be evaluated.

One of the main investigations to date into the use of onboard computers in freight vehicles has been carried out in the U.S. HELP program [185]. The HELP onboard computer study included a review of current applications of the technology in the motor carrier industry, and an analysis of ways in which onboard computers could be put to greater use in satisfying state and federal reporting requirements. Continued research within the HELP program will likely further investigate this latter issue in the near future. This work will focus on the integration of onboard computers with roadside location beacons produced as a result of HELP's extensive AVI research and development efforts.

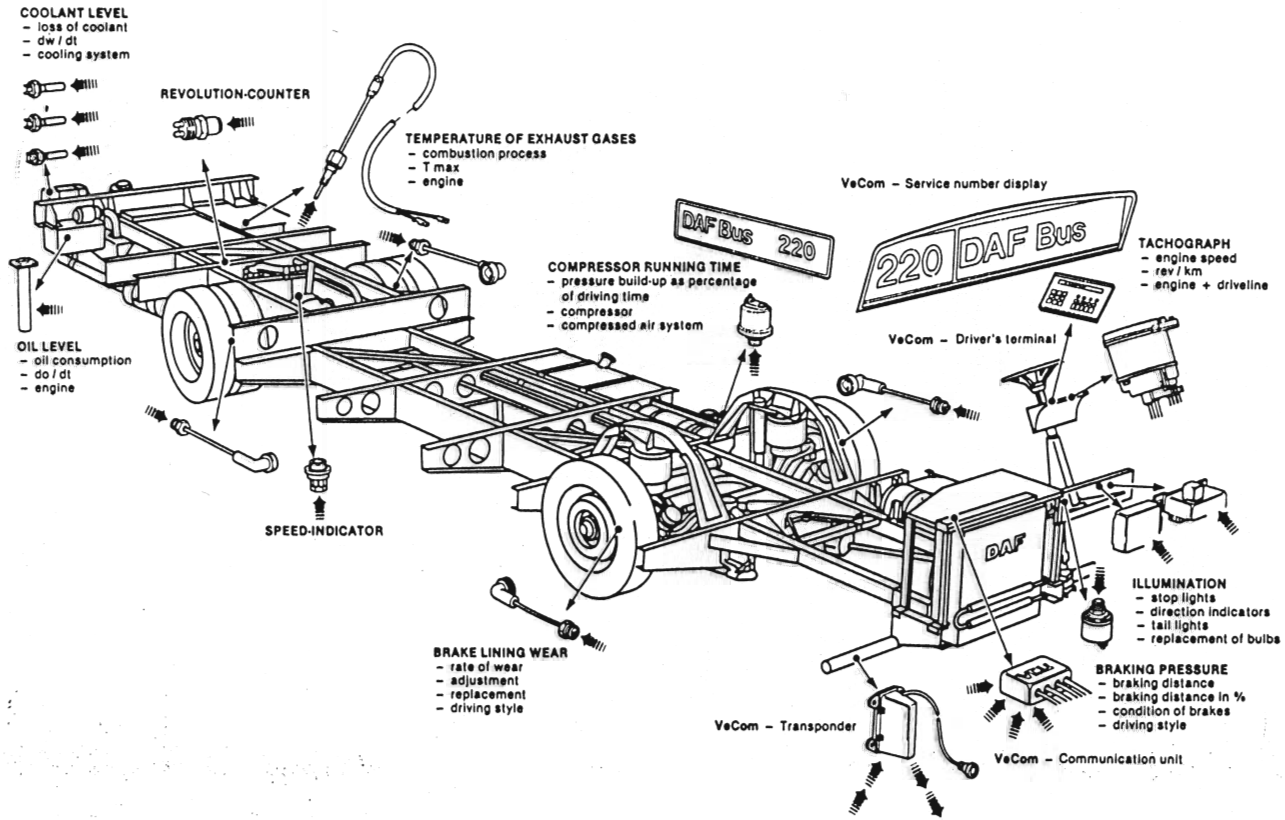

Figure 6.1 Sensors for vehicle condition monitoring

(Source: Reference 184)

The integration of onboard computers and roadside beacon technology under evaluation in the HELP program seeks to provide a method of automating driver log-keeping and reporting procedures. Beacons will be installed at state lines, and will be used to transmit coded messages containing time, date and site identification data. These data will be received in suitably equipped vehicles and relayed to an onboard computer for storage. The onboard computer will also record conventional information from a variety of sensors on the vehicle.

The data collected by the onboard computer will enable fleet operators to automatically generate a variety of management reports. One highly promising application of the system is the use of the data to automate weight/mile tax reporting. Weight/mile taxes are charged in a number of states, but are generally time consuming to calculate and difficult to verify. The HELP program will therefore aim to develop a standard onboard computer log format based on the beacon data that will satisfy the tax reporting needs of both motor carriers and auditors alike.

In the transit industry, an interesting example of the use of onboard computer technology has recently been evaluated in Reading, U.K. [186]. This system is called Optimizer and operates in a similar way to the "black box" recording devices used on airplanes. The Optimizer is wired into various circuits on the vehicle, providing data on speed, stops, starts and position. In addition, by monitoring whether the doors are open or closed, the system can establish whether the vehicle is at a boarding point or simply stationary in traffic. Boarding and alighting data are also collected by the Optimizer.

The Reading experiment began in January 1989 and ran for over a year. At the end of the evaluation period, the collected data were used to develop a vehicle schedule based on actually measured traffic conditions and demands. Data were also used to identify the nature, location and extent of delays, which were highlighted for further study by the highway authorities. As a result, it was possible for the transit operator to calculate the potential benefits of priority measures at the delay areas, both in minutes per journey and in overall running costs.

Smart cards are essentially miniaturized computers, and can therefore potentially perform many of the same functions as onboard computers but in a much more portable form. These cards have been developed relatively recently and are the focus of continuing attention within initiatives such as the European DRIVE program. Smart cards contain both microprocessor and memory elements and are able to perform calculations and manipulate data, independent of any device to which the card may be connected. The technology has only recently begun to find application in highway vehicles, and offers a number of potential benefits that have yet to be fully realized. In addition to replicating the role of onboard computers, some further possible uses are described in the following paragraphs.

One potential fleet management application of smart cards is to improve data collection for operations management. Scheduling of fleet vehicles currently relies largely on historical trip data gathered by labor-intensive manual methods. Smart cards could provide many of these data, leading to cost and time savings and providing a more reliable basis on which to plan fleet operations. For transit vehicles, a reader system mounted at the entry and exit doors could

also be used to interrogate smart cards carried by passengers and determine origin and destination information. This would provide a trip database for planning purposes.

Other statistical data could also be carried on the smart cards for use on transit vehicles, providing information on the user such as age, sex and frequency of travel. An important factor in public transportation marketing is price discrimination, through which different market sectors are identified and charges set reflecting different elasticities of demand. Airlines use this approach in their complex pricing structures aimed at maximizing business revenue while permitting leisure travel at much lower fares. Data collected using smart card technology could open up similar potential for transit price discrimination by time of day, age or route.

Smart cards could also be used for driver and fleet management. Drivers could be issued with a personal smart card, which would be placed on a reader in the vehicle during each journey. The smart card could then interact with other vehicle sensors to keep a log of driving hours, speeds, trip origins and destinations and other data. The card could also be used to record working and overtime hours for subsequent salary calculations.

Vehicle maintenance management is a further possible application of smart cards in fleet operations. Here, a smart card would be allocated to an individual vehicle within a fleet to maintain records of the vehicle's operational status on an hour-to-hour, day-to-day and month-to-month basis. Each smart card would be allocated to its vehicle at the start of a period and would be encoded with data from on-vehicle electronic sensors to provide information on performance and maintenance characteristics. This information could be downloaded by maintenance crews via a card reader at the end of the period. This would provide a log of information which could form the basis of vehicle maintenance planning.

6.4 Automatic vehicle identification

Automatic vehicle identification technology has already been discussed in Chapter 3 of this report, in the context of its role in advanced traveler information systems. This section discusses the further application of AVI to vehicle location monitoring for fleet management purposes.

The use of AVI for fleet monitoring and management involves the installation of transponders on vehicles in the fleet, and the siting of reader equipment at selected monitoring locations. This configuration can be used as a management tool to display the location and identity of vehicles at a central control point. Monitoring of performance in relation to a planned schedule can then be undertaken allowing early remedial action to be initiated where problems are identified [187].

For commercial vehicle operations, the most important current example of the use of AVI for fleet monitoring is the HELP program [70, 71, 72]. The aim of the HELP program is to research and develop an integrated heavy vehicle management system combining AVI, weigh-in-motion (WIM) and automatic vehicle classification

(AVC) technologies with a networked data communications and processing system. In support of this overall objective, the HELP program has developed an AVI system specification, and has also involved investigations into the use of onboard computers, discussed earlier in this chapter.

The HELP program is currently entering a major multi-state demonstration phase, known as the Crescent Demonstration. This will involve installation of the AVI, WIM and AVC components at 40 sites on Interstates 5 and 10 running between the states of Washington and Texas. The sites will be integrated using a networked communications and processing system, which will consist of roadside stations linked to regional and central computers.

Approximately five thousand freight vehicles selected from participating motor carrier fleets will be equipped with AVI transponders for use in the demonstration. The full Crescent system is scheduled to operate over a 12-month period when installation is completed, during which time the utility of the system will be assessed. This will include evaluation of the following system applications:

- * the use of the AVI, WIM and AVC data by motor carriers to assess vehicle fleet performance and simplify reporting procedures;
- * the use of data by state and federal agencies to support highway planning and maintenance activities;
- * the establishment of a computer database containing vehicle license and permit details, allowing immediate review of AVI monitoring locations;
- * real-time analysis of data by enforcement personnel at weighstations and ports-of-entry to establish manual enforcement needs; and
- * the ability to permit suitably-equipped vehicles to bypass checkpoints where AVI data reveal compliance with appropriate regulations.

Overall, the HELP system has the potential to achieve substantial benefits for both government agencies and the motor carrier industry alike. The Crescent Demonstration will provide the opportunity to establish the extent to which these benefits can be achieved, and to evaluate the performance of the HELP system. The results of the Crescent Demonstration will be used to make a decision on the feasibility of a fully-operational HELP system for widespread use in the U.S.

Outside of the U.S., AVI has been applied more widely to transit vehicles. In Europe, the implementation of AVI for fleet monitoring purposes has often been combined with signal preemption measures and, to a lesser extent, with passenger information services. The Philips VETAG system, for example, has been used for these purposes in the town of Almere in the Netherlands [188]. As well as providing for priority at traffic signals, the system displays operational data on a supervision screen in the control center. This enables an operator to establish the positions of individual buses, trace failure reports, initiate test programs for individual components, set intersection controllers to local operation and modify programs. When the control center is unmanned, information can be passed on via a data line to the operator's house, if required. Data

collected and stored by the central computer can also be used for economic and statistical analyses, and for maintaining logbooks and failure records.

The Vetag system has been implemented for FMCS applications in several other locations in Europe [189]. In France, the equipment has been used to support transit operations in the cities of Lyon and Grenoble. The system in Grenoble is used to provide data on the status of buses and streetcars, as well as offering priority at intersections and automatic point switching. Vehicle status data are displayed on a monitor at the control center and provide the position of the vehicles in the network. Different colors are used on the display to indicate whether vehicles are arriving, departing or stationary. In Lyon, meanwhile, the Vetag system is used to automatically identify vehicles as they enter the main bus terminal. Vehicles can then be automatically directed to the appropriate platform, ensuring optimum use of platform space and maximum convenience for passengers and crews.

More recently, in the U.S., AVI has been implemented at airport locations for the purpose of monitoring and controlling landside traffic, particularly taxicabs and transit vehicles. Examples of this include the international airports in San Francisco and Los Angeles.

The system installed at San Francisco Airport is based around the radio frequency AVI system manufactured by General Railway Signal [190]. Participation in the system currently extends to 1,400 vehicles equipped with tags. Readers and antennas are installed at three locations in the airport. The system also includes modems, computers and portable readers.

Transponders are mounted on the roof of participating vehicles, with antennas mounted overhead. The system is used to identify each vehicle, record the time and date, store, file and sort trips, and automatically bill the vehicle owner on a per trip basis.

In California, AVI equipment manufactured by Amtech Corporation has been installed at Los Angeles International Airport [191]. One of the principal applications here is to identify and monitor vehicles circulating within the airport landside network. These are then charged a fee according to the dwell time they spend within the airport. Transponders are installed on 5,000 vehicles participating in the scheme, which covers 40 lanes at the airport.

The system installed in Los Angeles was initially used to monitor the flow of door-to-door shuttles. Seven hundred of these vehicles currently operate at the airport, representing approximately \$150 million worth of business every year. The system produces a tape at the end of each month, providing a summary of the number of passenger pickups per vehicle. The tape is then used to input data to a mainframe computer, which carries out automatic billing based on the number of circuits of the passenger pickup level. The system has subsequently been extended to monitor the activity of vehicles supporting off-airport car rental companies, as well as limousines, charter buses and taxicabs. Payment processes are not automated for these vehicle types, however.

6.5 Automatic vehicle location

Perhaps the most widely used category of technologies and systems that has been applied to fleet operations is automatic vehicle location (AVL). AVL systems are different in emphasis from AVI systems, although both technologies can perform the function of identifying a vehicle. With AVL, the primary focus is on locating the vehicle at a specific time, rather than identifying the vehicle at a specific location [192, 193]. AVL is therefore concerned mainly with monitoring through temporal sampling, while AVI is aimed at monitoring through spatial sampling.

Some AVL systems are also similar in many respects to the onboard vehicle location systems described in Chapter 3. However, the emphasis in AVL systems is on providing vehicle location information to a central control, rather than to the driver himself. This overlap means that some systems can be used both for vehicle monitoring and management at a central point, and for providing positional and navigational information to the vehicle driver. One possible AVL system configuration is illustrated in Figure 6.2, though it is emphasized that there are several alternative technical options.

AVL systems allow fleet managers to utilize their vehicles more efficiently, thereby reducing vehicle miles traveled. In particular, they allow the fleet manager to schedule complex trips with multiple destinations in real-time, as orders are received or circumstances change. This reduces excess mileage caused by vehicles making multiple single-destination trips.

The location technologies used as the basis of most AVL systems involve DR, beacon proximity or radio-determination, as described in Chapter 3. The computed location information is then displayed to personnel in the control center either on a map display or as a coordinate listing. Fleet management software can also be utilized to manipulate the computed location data.

Several current AVL systems utilize LORAN-C radio determination as their basis. Motorola Inc. of Illinois currently manufactures and markets a LORAN-C system known as TRACKNET AVL-200 [294]. II Morrow Inc of Salem, Oregon [195, 196] also produces a LORAN-C based AVL system called the Vehicle Tracking System (VTS).

A third example of a U.S. manufactured AVL system is the METS TRACKER system [197] produced by METS Inc. of Florida and Indiana. The METS system is not reliant on one locational technology. LORAN-C is currently the preferred method for vehicle positioning, but METS will also interface to the Global Positioning System and to units with DR capability.

An example of an AVL system which combines a central vehicle monitoring function with provision of location advice to individual drivers is the GEC TRACKER system. GEC's system [197] utilizes DR augmented by updates from proximity beacons as the basis for location computation.

The vehicle position information calculated by the onboard receiver is generally monitored at a central control facility in AVL systems. Some means of automatically transmitting the data to the control facility is therefore

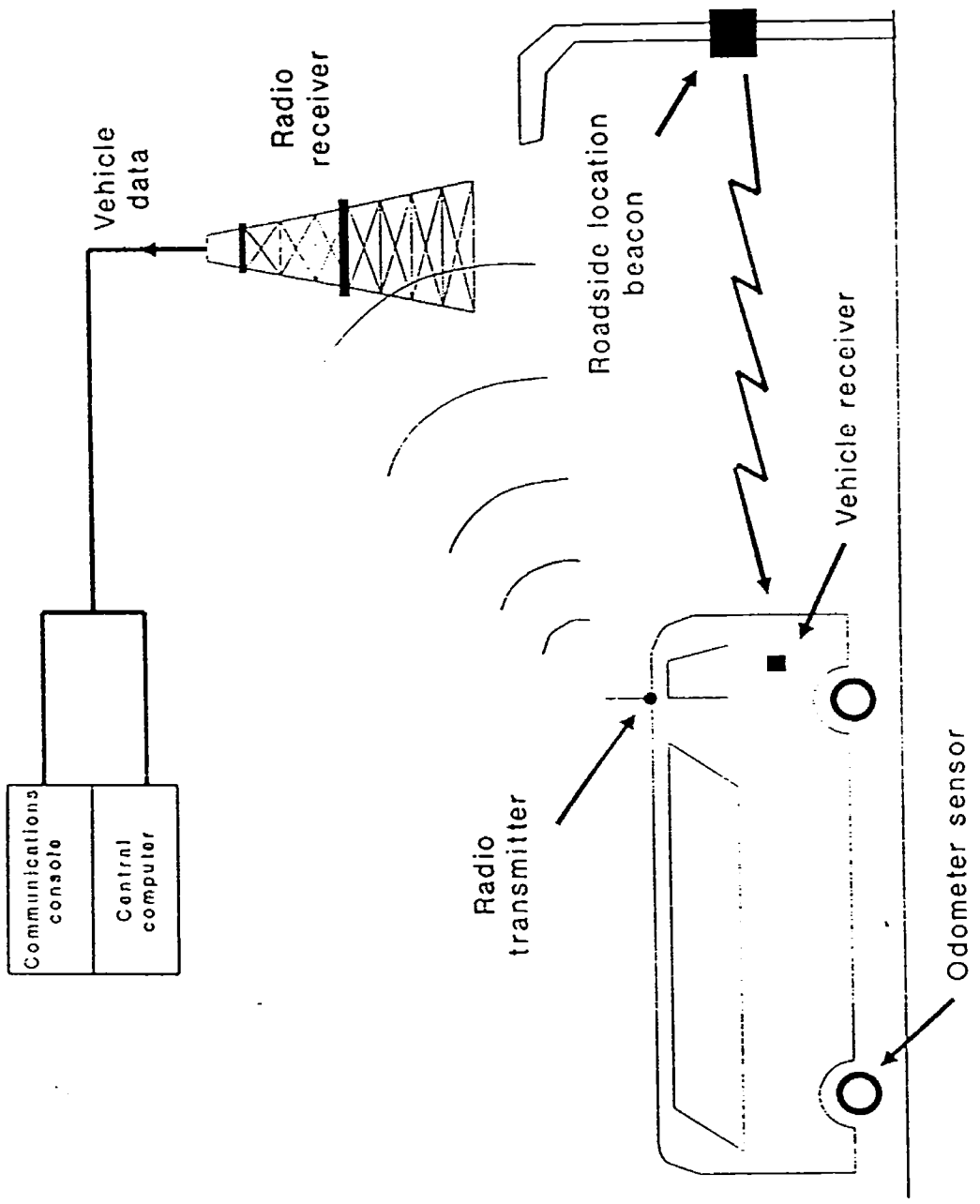

Figure 6.2 Typical AVL system configuration

required. Options for communicating this information include two-way mobile radio systems, onboard cellular telephones linked to modems, or land mobile satellite communications services. These communications options are each applicable to systems which use any of the ground-based or satellite-based location fixing techniques.

Finally, there is great potential for automatic vehicle location through use of the new Radio Determination Satellite Services (RDSS) recently licensed by the FCC [198, 199]. The FCC authorized three firms (Geostar Corporation, MCCA American Radiodetermination Corporation and McCaw Space Technologies) to construct, launch and operate radiodetermination satellite services in August 1986. A fourth firm (Omninet Corporation) received authorization in early 1987.

RDSS will provide commercially-operated satellite-based location services, together with the capability to send and receive short data messages. However, RDSS is not able to support traditional voice communications.

A major difference between RDSS and other satellite systems such as GPS is that the location determination takes place not at the vehicle, but at a stationary central location processor. This makes RDSS also well-suited as the basis of an AVL system, as the need for communication of position data from the vehicle to a central point is eliminated. Since RDSS also allows for data communication, it can provide location coordinates to an on-vehicle unit, with greater accuracy and using a much lower cost receiver than GPS.

6.6 Automatic vehicle monitoring

A review of AVI and AVL systems reveals many similarities between the two technology areas. Some AVL systems make use of AVI-based equipment to establish a vehicle's identity at a known location, while others utilize what may be thought of as "AVI in reverse" to transmit location data from a roadside beacon to the vehicle. Automatic vehicle monitoring (AVM) takes the use of AVI and AVL a step further by integrating identification and location data with other vehicle-specific information. This provides for more detailed vehicle monitoring applications on a continuous or semicontinuous basis.

As well as schedule adherence and vehicle location, other information that can potentially be gathered using AVM includes vehicle condition data, emergency status messages and, for transit vehicles, passenger counts and fare information. A typical AVM system configuration for transit vehicles is illustrated in Figure 6.3.

Passenger counting technologies have been incorporated into a number of fleet management systems in North America and Europe. An example was General Motors' transit information system (TIS), demonstrated on Cincinnati's Queen City Metro transit system [200]. This produced data on passenger boardings and alightings, as well as travel times, per bus trip or bus route segment. Vehicle locations were established using electronic beacons and bus odometer readings. The TIS was developed as an off-line system, however, and was therefore used for trip scheduling and route planning rather than real-time vehicle monitoring.

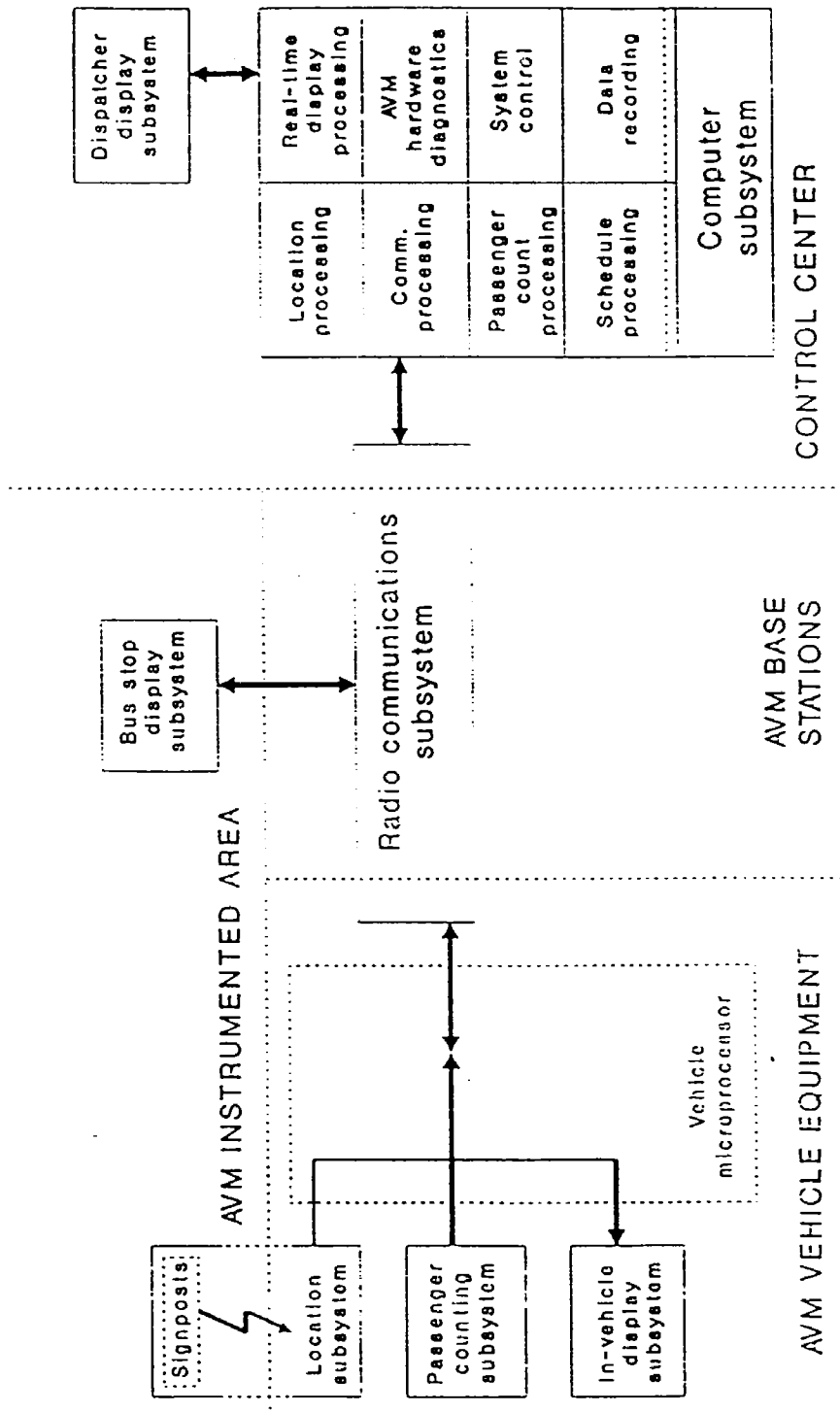

Figure 6.3 Typical AVM system configuration
 (Source: Reference 200)

Elsewhere, examples of passenger counting systems have demonstrated real-time communication of count data to a control center. In Ontario, Canada, passenger counting is achieved through the interruption of an infrared beam as travelers enter and leave the bus [201]. Count data are transmitted to a control center via roadside beacons, along with other information such as dwell time and location. The system has been designed as a planning tool, aiming to provide realistic schedules and fewer service irregularities.

The integration of onboard computers or smart cards with a communications link to a control center could potentially provide a powerful tool for monitoring the status of fleet vehicles. As well as providing information on vehicle location and schedule adherence, this would permit supervisors to monitor driver behavior and vehicle condition information collected by onboard sensors. For transit vehicles, vehicle occupancy levels could also be monitored in real-time, permitting operators to dispatch additional vehicles or to recall vehicles in response to demand.

AVM systems can also include a facility for the transmission of emergency messages to a control center. An example of this has been incorporated in the Toronto Transit Commission's communication and information system (CIS) [202]. The Toronto CIS enables bus drivers to contact the control center by pushing a button labeled "yellow emergency" when an automobile accident or similar situation is witnessed. Control center personnel are alerted by a buzzer, and can direct emergency services to the location of the accident which is automatically transmitted from the alerting vehicle. The CIS also has a silent alarm that can be activated when the driver is in danger. This automatically opens a voice channel, overriding other communications elements of the system. For freight vehicles, AVM can be of substantial benefit in the area of security, particularly when cargoes of especially high value are being carried.

One of the most prominent recent examples of AVM implemented in U.S. is a system developed for VIA Metropolitan Transit in the city of San Antonio, Texas [203]. The system tracks the location of transit vehicles, automatically warns dispatchers of delays, and provides two-way voice and data communications between dispatchers and drivers. In addition, it has the capability to monitor vehicle operating characteristics such as oil pressure and coolant temperatures, as well as operational information such as passenger counts. The system was put into full use in San Antonio in early 1989, following more than a year of successful testing in the city.

Outside of the U.S., one of the major examples of AVM is the Toronto CIS, discussed earlier in the context of its emergency alarm features. The CIS permits continuous automated monitoring of all surface vehicles operated by the Toronto Transit Commission (TTC), comprising buses, streetcars and trolley coaches. Like the system in San Antonio, the CIS uses a combination of roadside beacons and odometer readings to track vehicle location. All data, including vehicle location and information on mechanical problems input by the driver, are stored in an onboard microprocessor unit. The data are then transmitted to the control center every 10 seconds via one of 10 intermediate radio sites in the network. TTC plans to integrate some 2,000 surface vehicles into the CIS by the end of 1991 [204].

In Europe, the two-way communications capability of the VECOM AVI system developed by Philips has been used to implement a modular vehicle monitoring and management system known as TRANSMATION [205]. TRANSMATION differs from some other AVM systems, in that data processing and decision making are carried out on the vehicle, rather than at a control center. The onboard unit consists of a terminal with push buttons to input the driver's identity, direction control codes and other required data. The terminal is interfaced with a microprocessor unit, which also connects to a two-way transponder installed on the underside of the vehicle. In addition, the microprocessor can be connected to passenger counters and to an odometer for distance measurement. An example printout of data collected by the TRANSMATION system is presented in Figure 6.4.

6.7 Paratransit dispatching systems

Demand-responsive transit, or paratransit schemes have somewhat different needs to those of more conventional fleet operations. This has therefore led to the development of advanced technology systems specifically for paratransit operations.

In the U.S., for example, the Cape Cod Regional Transit Authority (CCRTA) has implemented a computerized management information system (MIS) for its b-Bus program [206]. When the MIS was first introduced in 1980, the b-Bus program represented a 25-vehicle regional advance-reservation, demand-responsive service. Annual ridership exceeded 150,000, with a significant proportion of elderly and handicapped passengers.

The computerized MIS was introduced by CCRTA as a replacement for the labor-intensive manual management procedures used previously. The MIS was developed to provide on-line scheduling and to generate various operational, managerial and statistical reports. In addition, data gathered and maintained by the MIS enabled CCRTA to add a billing and payment system to support an innovative fare collection system. This replaced the previous fixed quarterly fee payment system with monthly automated invoicing, based upon client type, trip purpose and distance traveled. Paratransit scheduling was not fully automated by the MIS, but the process was simplified by providing the receptionist with all necessary information in response to a trip request, and the automatic transfer of relevant information to the trip file.

Another system developed for paratransit is the West German Ruf-Bus system [207]. Ruf-Bus enables travel requests to be entered by passengers into computer terminals at bus stops. Data entered into the computer include the number of passengers in the party, so that a standard-sized bus, a mini-bus or a micro-bus can be dispatched in response to the request. The city of Friedrichshaven in West Germany has reportedly reduced annual transit operating costs by 20 percent following implementation of the Ruf-Bus system, and has also increased ridership, particularly in suburban areas.

Some high technology dispatching systems have also been developed specifically for application to taxicab fleets [208]. These combine computers, microprocessors and digital radio communications to improve taxicab management

(Lane) (Run) (Date)	(Base) (Batch) (Tuesday) (Direct number) (Arrival) (Time) (Departure) (Stop) (Speed) (In) (Out) (Occupancy) (Remarks)												
000000	000000	000000	000000	000000	000000	000000	000000	000000	000000	000000	000000	000000	000000
(Current) (Total)	(Distance) (Mileage)	(Time)	(Time)	(Time)	(Time)	(Time)	(Time)	(Time)	(Time)	(Time)	(Time)	(Time)	
000000	000000	000000	000000	000000	000000	000000	000000	000000	000000	000000	000000	000000	
330	24139	08:10:15	08:11:02	37	34	15.5	11	11	7	15	7	11	
330	24140	08:12:15	08:13:02	35	32	15.1	11	11	7	15	7	11	
430	24900	08:14:03	08:14:16	13	10	23.9	0	0	0	1	0	1	
370	25060	08:15:17	08:15:30	13	9	8.1	0	0	0	0	0	0	
440	25270	08:18:59	08:19:43	17	15	10.9	0	0	1	1	1	1	
330	25330	08:19:45	08:20:04	23	16	26.8	0	0	0	0	0	0	
330	25345	08:21:02	08:21:12	11	7	22.9	0	0	0	0	0	0	
330	25350	08:21:45	08:22:06	21	18	23.4	0	0	0	0	0	0	
330	25400	08:23:57	08:24:47	16	7	23.3	0	0	0	0	0	0	
330	25470	08:25:17	08:25:59	15	11	23.6	0	0	0	0	0	0	
330	25480	08:25:33	08:26:06	11	7	20.1	0	0	0	0	0	0	
330	25490	08:27:16	08:27:51	11	8	20.1	0	0	0	0	0	0	
330	25500	08:27:07	08:27:31	24	13	21.9	0	0	0	0	0	0	
330	25510	08:28:13	08:28:37	11	11	17.9	0	0	0	0	0	0	
330	25520	08:28:29	08:28:19	14	10	17.3	0	0	0	0	0	0	
330	25530	08:29:30	08:29:49	11	11	17.5	0	0	0	0	0	0	
330	25540	08:30:33	08:30:49	17	11	17.5	0	0	0	0	0	0	
330	25550	08:32:17	08:32:57	20	11	31.2	0	0	0	0	0	0	
330	25560	08:33:13	08:33:44	16	11	23.1	0	0	0	0	0	0	
330	25570	08:34:13	08:34:33	15	14	23.5	0	0	0	0	0	0	
330	25580	08:35:04	08:35:19	17	16	17.6	0	0	0	0	0	0	
330	25590	08:36:14	08:36:39	11	10	17.3	0	0	0	0	0	0	
330	25600	08:37:04	08:37:19	11	10	17.3	0	0	0	0	0	0	
330	25610	08:38:04	08:38:19	15	12	17.3	0	0	0	0	0	0	
330	25620	08:39:04	08:39:19	15	12	17.3	0	0	0	0	0	0	
330	25630	08:40:04	08:40:19	15	12	17.3	0	0	0	0	0	0	
330	25640	08:41:04	08:41:19	15	12	17.3	0	0	0	0	0	0	
330	25650	08:42:04	08:42:19	15	12	17.3	0	0	0	0	0	0	
330	25660	08:43:04	08:43:19	15	12	17.3	0	0	0	0	0	0	
330	25670	08:44:04	08:44:19	15	12	17.3	0	0	0	0	0	0	
330	25680	08:45:04	08:45:19	15	12	17.3	0	0	0	0	0	0	
330	25690	08:46:04	08:46:19	15	12	17.3	0	0	0	0	0	0	
330	25700	08:47:04	08:47:19	15	12	17.3	0	0	0	0	0	0	
330	25710	08:48:04	08:48:19	15	12	17.3	0	0	0	0	0	0	
330	25720	08:49:04	08:49:19	15	12	17.3	0	0	0	0	0	0	
330	25730	08:50:04	08:50:19	15	12	17.3	0	0	0	0	0	0	
330	25740	08:51:04	08:51:19	15	12	17.3	0	0	0	0	0	0	
330	25750	08:52:04	08:52:19	15	12	17.3	0	0	0	0	0	0	
330	25760	08:53:04	08:53:19	15	12	17.3	0	0	0	0	0	0	
330	25770	08:54:04	08:54:19	15	12	17.3	0	0	0	0	0	0	
330	25780	08:55:04	08:55:19	15	12	17.3	0	0	0	0	0	0	
330	25790	08:56:04	08:56:19	15	12	17.3	0	0	0	0	0	0	
330	25800	08:57:04	08:57:19	15	12	17.3	0	0	0	0	0	0	
330	25810	08:58:04	08:58:19	15	12	17.3	0	0	0	0	0	0	
330	25820	08:59:04	08:59:19	15	12	17.3	0	0	0	0	0	0	
330	25830	09:00:04	09:00:19	15	12	17.3	0	0	0	0	0	0	
330	25840	09:01:04	09:01:19	15	12	17.3	0	0	0	0	0	0	
330	25850	09:02:04	09:02:19	15	12	17.3	0	0	0	0	0	0	
330	25860	09:03:04	09:03:19	15	12	17.3	0	0	0	0	0	0	
330	25870	09:04:04	09:04:19	15	12	17.3	0	0	0	0	0	0	
330	25880	09:05:04	09:05:19	15	12	17.3	0	0	0	0	0	0	
330	25890	09:06:04	09:06:19	15	12	17.3	0	0	0	0	0	0	
330	25900	09:07:04	09:07:19	15	12	17.3	0	0	0	0	0	0	
330	25910	09:08:04	09:08:19	15	12	17.3	0	0	0	0	0	0	
330	25920	09:09:04	09:09:19	15	12	17.3	0	0	0	0	0	0	
330	25930	09:10:04	09:10:19	15	12	17.3	0	0	0	0	0	0	
330	25940	09:11:04	09:11:19	15	12	17.3	0	0	0	0	0	0	
330	25950	09:12:04	09:12:19	15	12	17.3	0	0	0	0	0	0	
330	25960	09:13:04	09:13:19	15	12	17.3	0	0	0	0	0	0	
330	25970	09:14:04	09:14:19	15	12	17.3	0	0	0	0	0	0	
330	25980	09:15:04	09:15:19	15	12	17.3	0	0	0	0	0	0	
330	25990	09:16:04	09:16:19	15	12	17.3	0	0	0	0	0	0	
330	26000	09:17:04	09:17:19	15	12	17.3	0	0	0	0	0	0	
330	26010	09:18:04	09:18:19	15	12	17.3	0	0	0	0	0	0	
330	26020	09:19:04	09:19:19	15	12	17.3	0	0	0	0	0	0	
330	26030	09:20:04	09:20:19	15	12	17.3	0	0	0	0	0	0	
330	26040	09:21:04	09:21:19	15	12	17.3	0	0	0	0	0	0	
330	26050	09:22:04	09:22:19	15	12	17.3	0	0	0	0	0	0	
330	26060	09:23:04	09:23:19	15	12	17.3	0	0	0	0	0	0	
330	26070	09:24:04	09:24:19	15	12	17.3	0	0	0	0	0	0	
330	26080	09:25:04	09:25:19	15	12	17.3	0	0	0	0	0	0	
330	26090	09:26:04	09:26:19	15	12	17.3	0	0	0	0	0	0	
330	26100	09:27:04	09:27:19	15	12	17.3	0	0	0	0	0	0	
330	26110	09:28:04	09:28:19	15	12	17.3	0	0	0	0	0	0	
330	26120	09:29:04	09:29:19	15	12	17.3	0	0	0	0	0	0	
330	26130	09:30:04	09:30:19	15	12	17.3	0	0	0	0	0	0	
330	26140	09:31:04	09:31:19	15	12	17.3	0	0	0	0	0	0	
330	26150	09:32:04	09:32:19	15	12	17.3	0	0	0	0	0	0	
330	26160	09:33:04	09:33:19	15	12	17.3	0	0	0	0	0	0	
330	26170	09:34:04	09:34:19	15	12	17.3	0	0	0	0	0	0	
330	26180	09:35:04	09:35:19	15	12	17.3	0	0	0	0	0	0	
330	26190	09:36:04	09:36:19	15	12	17.3	0	0	0	0	0	0	
330	26200	09:37:04	09:37:19	15	12	17.3	0	0	0	0	0	0	
330	26210	09:38:04	09:38:19	15	12	17.3	0	0	0	0	0	0	
330	26220	09:39:04	09:39:19	15	12	17.3	0	0	0	0	0	0	
330	26230	09:40:04	09:40:19	15	12	17.3	0	0	0	0	0	0	
330	26240	09:41:04	09:41:19	15	12	17.3	0	0	0	0	0	0	
330	26250	09:42:04	09:42:19	15	12	17.3	0	0	0	0	0	0	
330	26260	09:43:04	09:43:19	15	12	17.3	0	0	0	0	0	0	
330	26270	09:44:04	09:44:19	15	12	17.3	0	0	0	0	0	0	
330	26280	09:45:04	09:45:19	15	12	17.3	0	0	0	0	0	0	
330	26290	09:46:04	09:46:19	15	12	17.3	0	0	0	0	0	0	
330	26300	09:47:04	09:47:19	15	12	17.3	0	0	0	0	0	0	
330	26310	09:48:04	09:48:19	15	12	17.3	0	0	0	0	0	0	
330	26320	09:49:04	09:49:19	15	12	17.3	0	0	0	0	0		

and dispatching activities. Such systems can increase the efficiency and speed of service for conventional purposes, as well as providing particular benefits for the transport disadvantaged.

The major elements of an advanced taxicab dispatching system are a microprocessor-based unit located in each vehicle, a central computer system and a communications system. Communications are provided digitally via telephone or radio links, relieving drivers and dispatchers of the inefficient task of voice communication. Strategically positioned relay stations can be used to boost communications, if required.

In the operation of a typical advanced taxicab dispatching system, the customer would telephone the control center to request a vehicle. Appropriate data would be immediately entered into the central computer by an operator. The computer would then poll all available or soon to be available taxis, transmitting the pickup request to the closest vehicle. The microprocessor on the vehicle would respond automatically with a digital data message, enabling the dispatcher to confirm the customer's order and to provide an estimated time of arrival. As little as 15 seconds could be sufficient for this process to be completed.

In addition to providing this automated dispatching function, the system could be used to calculate demand, and to plan fleet requirements and allocate vehicles over an area. The system would also support several other valuable services, including ridesharing requests, standing account management and route planning for package delivery.

Principal examples of the implementation of advanced taxicab dispatching systems to date have been primarily in Europe. One of the most advanced systems is known as Taxi-80, which has been in commercial operation in Sweden since 1982. Similar systems are also operational in London, Zurich and Oslo. Although the technology has yet to be widely deployed in North America, however, the U.S. has developed technically similar systems for police departments, public utilities, fire departments and delivery firms.

6.8 Summary

This chapter has reviewed the application of a range of advanced technologies for fleet management and control purposes. Applied to fleet operations, IVHS approaches can be used to improve operational efficiency, to provide increased monitoring and intervention opportunities, and to enhance management and administration activities. Principal application areas include transit systems and commercial vehicle fleets, though emergency vehicles and taxicabs can also benefit greatly through the use of FMCS.

Fleet operations can be optimized through the use of computer software to identify efficient routes and schedules. Technologies such as onboard computers and smart cards can be used to automate data collection for input to software packages. Data can also be collected to improve or automate maintenance, management and reporting activities. FMCS approaches based around AVI, AVL or AVM provide fleet supervisors with opportunities for real-time monitoring and

control. Finally, systems have also been developed to satisfy the specific needs of demand-responsive vehicle fleet operations.

7. THE ENTERPRISE PROGRAM

7.1 Introduction

This chapter outlines the establishment of a cooperative IVHS venture involving U.S. state and federal organizations, Canadian provincial and national bodies and private sector firms from around the world. The program is proposed under the name ENTERPRISE, and will cover a range of research, development and operational evaluation activities for selected IVHS technologies. These will be undertaken by participants throughout the ATIS, ATMS, AVCS and FMCS areas of IVHS.

Following this introduction, the remainder of the chapter is divided into four further sections. The first of these provides a concise summary of the goals and objectives of the proposed ENTERPRISE program. Section 7.3 then describes potential participants in the initiative, identified through discussions with personnel in the appropriate government departments. The section outlines their specific areas of interest in IVHS, as well as providing an overview of current or planned activities that are applicable to ENTERPRISE. Opportunities for cooperation between states, based on geographical location or previous ventures, are also discussed.

Section 7.4 goes on to investigate the justification for the ENTERPRISE program. This is based upon consideration of the opportunities that will arise from the multi-participant initiative. The section therefore defines why ENTERPRISE will represent a more efficient mechanism for IVHS advancement than several individual, uncoordinated efforts.

The final section of the chapter outlines a number of projects and activities that could potentially be undertaken by the ENTERPRISE organizations. These have been identified in accordance with the needs and interests of the participants, seeking to take full advantage of existing systems and opportunities. The section includes brief descriptions of the benefits associated with each potential activity.

7.2 Objectives

The intent of the ENTERPRISE initiative is to create a major public/private program for the advancement of IVHS technologies. The initial core of the ENTERPRISE program will comprise a series of U.S. state and federal organizations together with Canadian provincial and national groups and private sector representatives. These will focus on a range of selected IVHS technologies and approaches, with each participant undertaking projects and activities that reflect particular needs and interests. Overall, principal objectives for the establishment of the ENTERPRISE initiative can be summarized as:

- * to establish a group of public and private sector bodies with similar goals and objectives and a feeling of mutual trust;

- * to facilitate each participant to select and conduct its own IVHS activities in accordance with specific needs and interests, and in agreement with common program goals;
- * to make rapid progress in the development and demonstration of selected IVHS technologies;
- * to operate with a small, tightly controlled management team responsible for coordinating the program in an effective manner;
- * to provide increased opportunities for communication and cooperation between participating organizations;
- * to create an efficient mechanism for disseminating the results of the program to higher bodies such as IVHS America, and broadly throughout the IVHS community;
- * to achieve true public/private sector cooperation, providing cost saving benefits and ensuring economically sound technology development;
- * to make optimum use of funding sources by avoiding duplicative efforts and focusing on carefully targeted areas; and
- * to utilize program synergy, to increase the benefits of IVHS initiatives for program participants, and thus to make a greater overall contribution to the advancement of IVHS.

7.3 Program participants

This section outlines a number of potential participants for the initial core of the ENTERPRISE initiative. These have been identified through discussions with personnel in various government departments concerned with highway transportation. Discussions were focused upon levels of interest in the ENTERPRISE program, specific areas of interest in IVHS, and ongoing or planned IVHS initiatives. Opportunities for cooperative research activities and program liaison were also considered. This work led to the identification of the following potential ENTERPRISE participants:

- * Arizona Department of Transportation;
- * Colorado Department of Highways;
- * Iowa Department of Transportation;
- * Minnesota Department of Transportation
- * New York State Department of Transportation;
- * U.S. Federal Highway Administration;

- * Ontario Ministry of Transportation; and
- * Transport Canada, Transportation Development Centre.

ENTERPRISE will also potentially include a number of private sector corporations concerned with highway transportation. Options in this area are currently under investigation and will be finalized in the future ENTERPRISE organization and implementation activities. Opportunities for coordination with European and Japanese research organizations through the GALACTIC bridging project will also be identified during these final planning stages.

The remainder of this section comprises further details on each of the proposed North American government participants.

Arizona Department of Transportation

The first proposed participant for the ENTERPRISE initiative is ADOT. Among its current IVHS-related activities, ADOT leads the HELP program, recognized as a keystone of the U.S. national IVHS initiative. Since its inception in 1983, HELP has made major advances in several IVHS areas, particularly digital road-vehicle communications technologies through its AVI research and development program. This work, together with ongoing HELP AVI research, will form an important foundation upon which many of the proposed ENTERPRISE activities can build.

Another important ongoing activity of ADOT is the implementation of the Phoenix Freeway Management System. This has been designed to provide comprehensive monitoring and control facilities for the Phoenix freeway network. The system is intended to maximize utilization of the physical capacity, minimize the adverse effects of breakdowns and provide an optimum response to incidents. A number of advanced technologies will be used in the system, including a computerized central control facility, closed circuit television, ramp metering, incident detection and traffic signal integration. Motorist information will also be provided by the system through variable message signs and highway advisory radio, integrated with the various monitoring and control elements. Overall, the Phoenix Freeway Management System represents a state-of-the-art approach that is being brought on-line over the largest network of urban freeways recently constructed in any city of the world.

Most recently, ADOT has commissioned a study for the development of an internal IVHS program for the State of Arizona. This work was undertaken by CRC for ADOT, and led to a proposal for an in-state program known as MIDAS. MIDAS will be a ten-year research, development and operational evaluation initiative with the ultimate objective of AVCCS. As described in Chapter 5, AVCCS would combine a number of automated vehicle control concepts with traveler information and vehicle navigation systems. The approach has been identified as having particular interest for ADOT personnel, and is therefore seen as the logical goal of the internal MIDAS effort. Further details on the MIDAS initiative are presented in later chapters of this report.

Colorado Department of Highways

The second proposed co-participant in the ENTERPRISE initiative is the Colorado Department of Highways (CDOH). Discussions with CDOH personnel have identified three primary areas of interest, as follows:

- * heavy goods and hazardous materials monitoring;
- * demand management; and
- * traffic operations and surveillance.

Among its current IVHS-related activities, CDOH is a member of the HELP program, described previously in this report. This connection provides an existing link with many other proposed ENTERPRISE participants. The state has also been implementing ramp metering controls at freeway entrances throughout the last decade. Freeway and ramp flows are monitored continuously by computer to detect incidents and demand problems. Colorado's ramp metering network has gradually evolved into an advanced system that will potentially provide a valuable base for exploitation of further IVHS approaches.

In addition to the ramp metering controls, a limited number of high-occupancy vehicle (HOV) regulations are imposed in Colorado. In Denver, however, significant extensions to current HOV regulations have been proposed for introduction within the next three to four years. In the light of the increased efficiency of HOV travel over private, single-occupancy vehicles, this will be an avenue worthy of exploration within ENTERPRISE.

There are also several further projects that have been proposed or considered by CDOH which would be highly relevant to ENTERPRISE. The Department has recently prepared a proposal for the development and implementation of an advanced traffic operations surveillance system. This is intended for use on Interstate I-25, which runs in the north-south direction in the City of Denver.

In the area of heavy goods vehicle movement, CDOH has investigated the development of a statewide hazardous materials monitoring system. This would be based upon AVI technology, in combination with other data communication and processing elements. Through Colorado's involvement in the HELP program, the hazardous materials monitoring system could potentially be developed as an adjunct to HELP, making use of the same AVI technology. Colorado's close proximity to a number of other HELP states would provide valuable opportunities to extend the system to multi-state coverage, following initial in-state development and evaluation.

Colorado has also expressed interest in the installation and integration of demand management and traffic operations surveillance equipment. Potential sites for this activity include the Denver metropolitan area, as well as Interstate I-70 between Denver and the State of Utah.

Finally, CDOH is currently in the process of implementing a major IVHS program for the State of Colorado which would make a significant contribution to the overall ENTERPRISE effort. CDOH has prepared a draft scope of work for the

development of an integrated IVHS master plan and initial demonstration project for the Denver area. The master plan will incorporate traffic management, incident management and motorist information strategies, and will integrate a number of already existing and planned systems. These include the Denver ramp metering system, highway advisory radio, the SCAN ice sensor system, coordination of traffic signals, the proposed I-25 traffic management system and the use of cellular phones and packet radio for data transfer and incident reporting.

The IVHS master plan prepared for CDOH will also include the identification of a corridor for the first Denver smart corridor demonstration project. This will be developed to incorporate existing and proposed IVHS elements, and will be implemented as a demonstration of public, private and academic partnership.

Iowa Department of Transportation

The third proposed participant for the ENTERPRISE initiative is the Iowa Department of Transportation (IADOT). The State of Iowa consists primarily of open, rural expanses with low population densities. Iowa is therefore less affected by traffic congestion than many other areas. The development and application of IVHS approaches in Iowa should therefore address areas such as safety or traveler information, rather than seeking to reduce or accommodate congestion.

One important consideration in identifying the role of Iowa in the ENTERPRISE program is its frequently harsh environment in terms of remoteness and weather. In this respect, traveler information and warning systems will be of greatest use in the State of Iowa. These should be able to detect hazardous weather conditions or incidents, transmitting the resultant data to rural motorists. Similar approaches could be used to identify the presence of school buses or other potential hazards. The investigation of these systems in Iowa will provide an important service in the state, while allowing other ENTERPRISE participants to concentrate their resources on congestion-related activities.

Like other proposed participants, IADOT is a member of the HELP program and therefore has well-established links that will be valuable in the ENTERPRISE effort. IADOT is also fortunate to contain respected professional staff who will provide an important element of leadership within ENTERPRISE. Further details on this subject are presented in later sections of this report.

In addition, Iowa has previously undertaken cooperative transportation research with the Minnesota Department of Transportation, also proposed as an ENTERPRISE participant. The common state border of Iowa and Minnesota will provide opportunities for further collaboration within the ENTERPRISE initiative.

Minnesota Department of Transportation

Mn/DOT is the fourth participant proposed for the initial core of the ENTERPRISE group. Mn/DOT is currently in the process of implementing the GUIDESTAR IVHS program in conjunction with the University of Minnesota Center for Transportation Studies. GUIDESTAR is one of the most important and wide-ranging of all of the

individual states' IVHS efforts, and was the only initiative mentioned by name in the recently-published National Transportation Policy. Mn/DOT has selected CRC to perform management consultant services for GUIDESTAR, including identification and definition of projects, and development of an overall program schedule.

While the individual projects of GUIDESTAR have not yet been fully defined, however, some of its principal themes and activities are already known. One of the major elements of GUIDESTAR will be a video imaging vehicle detection system called Autoscope. The system uses video cameras for traffic monitoring, with the resulting images being analyzed by computer software. This enables traffic-flow information to be extracted for surveillance and control purposes. Mn/DOT is planning to evaluate Autoscope on a major Interstate freeway corridor in the Twin Cities of Minneapolis and St. Paul, in conjunction with the Center for Transportation Studies and the FHWA.

In the immediate term, GUIDESTAR will improve traffic management using conventional video monitoring of traffic, together with information received from the State Highway Patrol, DOT vehicles and citizens band radios. This will ultimately be complemented by data derived from the Autoscope system. Research is also being undertaken toward the development of simulation models capable of accepting Autoscope data. These will use artificial intelligence to review alternative strategies for controlling congestion.

In the area of traveler information, GUIDESTAR's immediate efforts will focus upon increasing the availability of traffic data for drivers using radio transmissions and variable message signs. This includes an already existing HAR system which broadcasts updated traffic data on an eight-minute cycle during rush hours. Updates are continuous during major incidents. GUIDESTAR will also involve installation of dynamic signs operated by radio signals. These will direct motorists to tune to the correct radio station for receipt of pertinent traffic information. Human factors aspects of ATIS technologies will also be evaluated in GUIDESTAR laboratory simulations.

Another area of GUIDESTAR research is commercial vehicles and fleet navigation, represented by the FMCS category of IVHS technologies. This includes automatic traffic signal control by emergency vehicles, as well as the use of expert systems for truck permitting.

To evaluate a broad range of IVHS approaches included in GUIDESTAR, Mn/DOT is currently establishing a major test corridor in the Twin Cities metropolitan area. This is to be located around a three-mile section of Interstate I-394. The corridor will include more than 20 Autoscope cameras integrated with a network of conventional traffic management, information and data collection equipment. A region-wide traffic communications network is expected to be in place by 1995, and will connect and monitor nearly 300 miles of freeways and arterials in the Twin Cities.

In addition to GUIDESTAR, Mn/DOT is currently involved in the HELP program. As described previously, the State has undertaken cooperative transportation research with Iowa, potentially providing a platform for further interstate projects. Minnesota's border with Canada also offers opportunities for

collaborative projects with the Province of Ontario which can be explored as part of the ENTERPRISE program.

New York State Department of Transportation

The fifth participant proposed for inclusion in the ENTERPRISE initiative is the New York State Department of Transportation (NYSDOT). The State of New York contains a number of congested cities to which IVHS technologies can be applied, as well as more rural environments in the upstate area. New York also includes several toll facilities, many of which are in the process of evaluating or implementing automated toll collection using AVI technology. This will provide opportunities for traffic monitoring and traveler information that can be investigated as part of the ENTERPRISE program.

Discussions with state personnel have identified a number of interests within the overall field of IVHS. Principal areas of interest include the following:

- * traffic management and surveillance;
- * demand management and the promotion of transit and rideshare; and
- * IVHS applications at U.S./Canadian border crossing points.

Among its current IVHS-related activities, NYSDOT operates the INFORM (Information for Motorists) system on the Long Island Express Parkway and Northern State Parkway. INFORM uses 2,400 traffic sensors to collect data which are relayed to a central control unit. Citizens band radio is also used as a source of traffic information for INFORM. Variable message signs then serve to alert motorists to congestion, as well as suggesting alternative routes when appropriate.

In addition to its traveler information elements, INFORM is also used for traffic management purposes. This includes control of 110 traffic signals on the arterial network which is integrated with the freeway system. Ramp metering is also incorporated into the INFORM system.

Building on the INFORM system, NYSDOT is currently in the process of implementing the Visual Traffic Information Project (VTIP). This is used to display data collected by INFORM on television and computer screens. The VTIP display shows the entire INFORM highway network, together with traffic speeds on key sections. Data are updated every minute to maintain accuracy. The system has already been installed in department stores and office buildings, with other potential information outlets including personal computer networks, shopping center displays and in-vehicle receivers.

Beyond the VTIP enhancement to INFORM, NYSDOT is proposing to extend the system into additional areas. The first of these will cover installation of the system on the Southern State Parkway and adjacent arterials between the Cross Island Parkway and State Route 27 on Long Island. Additional elements of this proposed study would involve an assessment of the feasibility of installing ramp metering on the Parkway, including bypass lanes for HOVs. An assessment of light truck

usage on the Parkway with AVI technology is also proposed, including entrance clearances using WIM and height scanning systems.

In conjunction with these proposals for the Southern State Parkway corridor, NYSDOT is further seeking to increase coverage of INFORM to all freeways, parkways and major arterials on Long Island from the New York City area through to State Route 112 in Suffolk County. This will include consideration of the introduction of ramp metering on extended sections of the Southern State Parkway.

Another current NYSDOT project is Time-Based Coordination (TBC) of traffic signals. This coordinates geographically-linked traffic signals with uniquely programmed software. A prototype TBC system has been installed for the control of five intersections over 1.8 miles of roadway leading to Interstate I-787 in Albany. Since its introduction in June 1990, the system has increased average rush hour speeds by 7 mph in both the morning and evening peaks. The system is expected to be extended to 80 signals on the state highway system by 1992, at an average cost of just \$800 per intersection. The TBC software and controller is to be made available throughout the state, providing opportunities for its use in conjunction with other IVHS approaches in New York as part of the ENTERPRISE program.

In the Rochester urban area, NYSDOT is currently proposing to integrate 300 traffic signals operated by Monroe County with traveler information systems on the freeway network. Freeways and surface streets would be controlled by one computerized system, which would relay pertinent information to travelers via variable message signs. This would include information on congestion and rerouting recommendations, as well as the availability of parking in the major lots and garages of downtown Rochester. The feasibility of expanding the system to other limited access highways would be examined in the study.

NYSDOT is also one of the member organizations of TRANSCOM, described in Chapter 2 of this report. TRANSCOM's IVHS-related activities include the implementation of an alpha-numeric radio paging system in the New York/New Jersey area. This is used to transmit coded messages throughout the region providing real-time traffic information. The system therefore reduces notification time, permitting affected agencies to respond quickly. TRANSCOM is also investigating the use of AVI transponders installed initially for automated toll collection as a source of data for traffic management and traveler information systems. NYSDOT is similarly considering the use of AVI-equipped vehicles as traffic probes in Westchester County.

Discussions with state personnel also identified an interest in IVHS applications for border crossings between New York and Ontario, Canada. These would seek to reduce the levels of congestion and inconvenience caused by current checking procedures at crossing points. Possible uses of advanced technologies could include "electronic sealing" of trucks, and advanced clearance based around AVI technology.

U.S. Federal Highway Administration

The sixth organization proposed for involvement in the ENTERPRISE program is the FHWA. In particular, the FHWA's Office of Traffic Operations and IVHS is likely to play a major role in the initiative. The Advanced Systems Division of this office is responsible for a number of FHWA tasks, including the coordination of IVHS projects, program plans and budgets, input to the development of a national IVHS program, participation in standard setting activities and assistance in the formation of public/private partnerships for state or local efforts. The Traffic Operations Division, meanwhile, undertakes activities such as the preparation of traffic management program policies, development of methodologies for measuring and evaluating traffic performance, and human factors support for IVHS developments.

At a strategic level, therefore, FHWA will potentially play an important role in overseeing and supporting the various ENTERPRISE activities. This will likely be undertaken from both FHWA Headquarters in Washington, D.C., and divisional offices corresponding to the ENTERPRISE program participants.

A further option is for FHWA to become more actively involved in some of the ENTERPRISE activities, rather than simply maintaining an oversight role. As an illustration of this, FHWA is already jointly responsible for several major North American IVHS projects. These include a number of studies that are being performed in conjunction with proposed ENTERPRISE participants. Among these are the New York INFORM project, the HELP program and its Crescent Demonstration (for which FHWA has recently committed \$5 million), Advantage I-75, and the evaluation of Autoscope as part of the Minnesota GUIDESTAR program.

Ontario Ministry of Transportation

The seventh participant proposed for inclusion in the ENTERPRISE program is the Province of Ontario Ministry of Transportation. The involvement of Ontario in the initiative will provide an important Canadian input, ensuring that ENTERPRISE is truly North American in scope. Ontario's borders with U.S. participants will also provide valuable opportunities for collaborative, cross-border projects, as discussed earlier in this section.

Discussions with Ministry of Transportation personnel in Ontario have identified two principal areas of interest in IVHS. These cover fleet monitoring and management, and in-vehicle route guidance.

Ontario's interest in fleet monitoring and management is demonstrated by its provincial transit control systems, and by its proposed inclusion in the Advantage I-75 project. In the area of transit, the Communication and Information System (CIS) implemented by the Toronto Transit Commission (TTC) is one of the world's major examples of automated vehicle monitoring. The CIS permits continuous automatic monitoring of all surface vehicles operated by TTC, using a combination of roadside beacons and odometer readings to track vehicle location. Location data are transmitted to the control center every 10 seconds, in conjunction with mechanical information and details input by the driver. The

CIS also includes a facility for the transmission of emergency messages to the control center.

A system similar to the CIS is currently being installed in another city in Ontario. The system, being introduced by the Ottawa-Carleton Regional Transit Commission (OC Transpo) includes vehicle identification devices, roadside readers and computer storage and processing equipment. The system is being installed as the first stage of a three-phase project, with phase two and three enhancements scheduled to continue until 1996.

With regard to trucking operations, Ontario is a potential participant in the proposed Advantage I-75 project. Advantage I-75 is a concept proposal for a heavy vehicle monitoring program involving a number of U.S. states and the Province of Ontario. Its aim is to allow an AVI-equipped and properly-documented truck to travel the entire length of Interstate I-75 at mainline speeds with no more than a single stop at a weight enforcement station. As currently envisioned, each participating truck entering the corridor would be stopped at the first weigh station for static weighing and inspection. Information would then be transmitted to downstream weigh stations, allowing vehicles to bypass stations within a permitted time window.

A commercial satellite-based communications and location system for commercial and fleet vehicles has also recently been launched from Ontario. The system, called RoadKIT, was the result of a six-year research and development program undertaken by three private sector firms and the Ministry of Transportation. In addition to providing vehicle location facilities, the system can also support voice communications, facsimile, voice mail, call forwarding and paging.

In the area of traveler information, the Ontario Ministry of Transportation initiated a project in conjunction with TTC and the Metropolitan Toronto Transportation Department. This is examining the feasibility of collecting detailed, real-time travel speed data on major routes in Toronto and on Highway 401, the main east-west highway traversing the city. Freeway data are to be collected using the new Traffic Management System, a 10-mile section of highway equipped with loop detectors, CCTV cameras, communications equipment and variable message signs. Arterial travel speed information will be obtained from inductive loops, while the CIS will also be reviewed as a source of suitable data.

One of the applications of this system envisioned in Ontario is the provision of reliable, timely and consistent traffic data for input to route guidance systems. In this area, the Ministry of Transportation has provided funding assistance for the development of an efficient routing algorithm. Further advancement of this concept could be undertaken within ENTERPRISE, including development of in-vehicle hardware and a compatible traffic information broadcasting system.

Transport Canada, Transportation Development Centre

The eighth and final organization proposed for the initial core of the ENTERPRISE program is the Transportation Development Centre (TDC) of Transport Canada. TDC is the central research and development arm of Transport Canada, responsible for

managing a research program aimed at improving the safety, efficiency and accessibility of the Canadian transportation system.

TDC has recently sponsored two exploratory studies of IVHS technologies. The first of these was completed in 1989 and involved evaluation of in-vehicle navigation and mobile information techniques. The second study, completed in 1990, focused on an examination of the potential of vehicle monitoring, fleet monitoring and travel support systems. This led to recommendations for the establishment of a Canadian national IVHS program, which could potentially provide a major input to TDC's involvement in the ENTERPRISE initiative.

As part of a national body responsible for transportation, the involvement of TDC in the ENTERPRISE program is consistent with the participation of FHWA in the U.S. However, the responsibilities of these two groups are slightly different in their respective countries. While FHWA primarily plays a role of overseeing and coordinating highway research across the U.S., TDC is more responsible for initiating and managing individual studies. TDC will therefore likely perform its own studies as part of the ENTERPRISE program, in contrast to the broader role of FHWA.

TDC is already participating in two IVHS activities that are being undertaken jointly by U.S. and Canadian participants. In the HELP program, TDC has voting membership of the Policy and Executive Committees, in conjunction with motor carrier representation from the Province of British Columbia. TDC is also involved in the Advantage I-75 study, working with the Province of Ontario and several U.S. states.

7.4 Benefits of the ENTERPRISE program

The ENTERPRISE initiative is proposed as a coordinated effort involving a number of cooperating members. However, an alternative approach would be for each proposed ENTERPRISE participant to carry out an independent IVHS research and development effort. This therefore raises two important questions that require consideration. First, what is the overall advantage of the approach represented by ENTERPRISE over several individual efforts? Second, what are the potential benefits of involvement in the ENTERPRISE program for each of the prospective participants? These issues are discussed in the following paragraphs, with principal findings presented in summary form in Table 7.1.

The ENTERPRISE initiative can be thought of as an umbrella program, under which the various participating members will perform a range of IVHS activities. Although these will primarily be undertaken independently of one another, the GALACTIC bridging project will ensure that a coordinated approach toward IVHS advancement is adopted, and that communication and liaison elements are maintained.

Overall, therefore, the ENTERPRISE initiative will permit each state to focus on its particular areas of interest and develop IVHS solutions in response to specific needs. The ENTERPRISE program will not attempt to dictate the IVHS activities to be undertaken by its individual participants. Rather, the

Overall Benefits	Benefits for Participants
Provides opportunities for interstate/international collaboration	Offers increased opportunities for cooperative ventures
Prevents unnecessary duplication in individual efforts	Provides an efficient mechanism for coordination and information exchange
Covers a broad range of IVHS technologies	Allows participants to focus on specific needs and interests
Allows fast-track IVHS technology development	Increases opportunities for transferring results between participants
Makes optimum use of funding sources	Improves recognition and reputation of participants
Offers an efficient method for reporting many IVHS activities	<p>Momentum and recognition increase opportunities to leverage federal funding</p> <p>Provides opportunities for use of others' facilities and equipment</p> <p>Enables participants to receive informed assistance and comment from fellow members</p>

Table 7.1 Benefits of the ENTERPRISE program

initiative will seek to provide a mechanism for cooperation and a forum for the exchange of information between a variety of state efforts.

While individual participants may focus on relatively narrow areas of IVHS, their diverse range of needs and interests will result in the investigation and development of technologies from across the IVHS spectrum. Coordination between participants will also ensure that work is not replicated in different projects, while guaranteeing the transferability of research results between states. However, it will be possible for participants undertaking similar activities to learn from the experiences of others. This coordinated approach will therefore fast-track IVHS technology development, making optimum use of funding sources.

Participants will also benefit from involvement in ENTERPRISE in performing their individual IVHS research and development activities. In developing concepts, projects and bid documents, members will be able to call upon the advice and assistance of fellow participants when required. Valuable support in the form of feedback and suggestions from others will additionally be available as IVHS projects progress. Since an important element of ENTERPRISE will be frequent liaison and communication, participants will be in a position to assist and advise one another on a fully informed basis. When the need arises, it may also be possible for researchers to use equipment or testing facilities provided by other members through the coordinated ENTERPRISE structure.

A further advantage of a multi-participant approach toward IVHS development is that it provides opportunities for interstate and U.S./Canadian cooperation. These opportunities would not be provided by isolated efforts, leading to severe gaps in the results of individual initiatives. Transportation systems do not simply stop at state lines or international boundaries, and issues concerning use of IVHS technologies across borders must therefore be resolved.

The ENTERPRISE initiative will also provide an efficient mechanism for collecting and distributing data within the group, and for external reporting of the program's IVHS activities. Where details from Japanese or European research are required by a particular participant, for example, involvement in ENTERPRISE will create a significant increase in the number of useful contacts. Data gathered from outside the ENTERPRISE program will be efficiently disseminated within the group, to the benefit of all participants. Similarly, information on the various ENTERPRISE activities will be provided in a coordinated fashion to higher bodies such as IVHS AMERICA, and more broadly throughout the IVHS community.

Involvement in ENTERPRISE will also boost participants' reputations for high technology transportation research and development. The benefits of this will ultimately include economic growth, commercial prosperity and an increased standard of living.

Finally, while individual initiatives have the potential to make significant advances in IVHS, their placement within a coordinated program will add to the recognition that will be obtained. The successes of the HELP program clearly demonstrate the value of a high national profile which multi-state efforts command. This will help participants to acquire private sector partners for research and development activities and to leverage federal funding, where required.

7.5 ENTERPRISE activities

This section outlines a series of projects and activities that could potentially be undertaken within the ENTERPRISE program. These have been developed in accordance with the needs and interests of the proposed program participants. In addition the study team has sought to avoid areas of overlap between participants, while ensuring coverage of a wide range of IVHS technologies and, in particular, digital communications approaches.

The projects and activities outlined in this section are intended for review by the proposed ENTERPRISE program members. It is important to note that the objective is not to dictate the direction of IVHS studies for each of the member organizations. Rather, ENTERPRISE seeks to provide a mechanism under which each participant can undertake individually selected activities in a coordinated framework. Ultimately, therefore, each ENTERPRISE participant will be responsible for finalizing its activities for inclusion in the program.

Arizona Department of Transportation

As discussed in Section 7.3 of this chapter, ADOT has recently commissioned the development of a detailed IVHS program plan for the State of Arizona. The resulting MIDAS proposal outlines a series of projects and activities that will form the basis of IVHS research in Arizona over the next decade. As such, Arizona's contribution to the ENTERPRISE program will effectively be represented by the internal MIDAS initiative. Further details on MIDAS are presented in subsequent chapters of this report, and may provide a useful illustration for other ENTERPRISE participants in their own internal IVHS program development activities.

Colorado Department of Highways

CDOH is currently in the process of implementing an initiative that will result in the preparation of an IVHS master plan for the State of Colorado. This will provide a major element of Colorado's involvement in the ENTERPRISE program. In particular, the master plan will include proposals for a smart corridor in the Denver area, which will be used to develop and evaluate a range of IVHS approaches.

While Colorado's IVHS activities are therefore to be defined in detail in the development of the state's overall master plan, three particular areas of IVHS research have been selected by the study team for initial consideration by the CDOH. These are outlined in the following paragraphs. The three areas are:

- * hazardous materials monitoring;
- * demand management; and
- * rideshare management and marketing.

In the first selected area, a project is proposed that would lead to the implementation of a corridor demonstration of a hazardous materials carrier monitoring system. This would be based upon the results of current and planned HELP AVI research. Other technologies that could be included within the system include AVL and a data communications and processing system.

The hazardous materials monitoring study is proposed as a multi-phase effort. Initial stages will focus on the needs of the state in the area of hazardous materials, together with a review of applicable technologies. This work will provide the basis for selection of a preferred system design and mode of operation. Equipment will then be procured and the system will be installed over a demonstration corridor in Colorado. Finally, the system will be evaluated, and conclusions will be drawn on its overall utility and on requirements for further development and enhancement.

The system will provide improved control of hazardous materials movements, including automatic identification and location of vehicles; identification of the load type and its hazardous nature; review of the vehicle's proposed route and origin; and facilities for preclearing vehicles at check sites to reduce travel times of hazardous materials. Overall, therefore, the system should provide substantial safety benefits for the State of Colorado. Management and administrative operations concerning control of hazardous materials movements should also be improved as a result of system implementation.

The second area of research identified for consideration by the CDOH is the investigation and application of integrated demand management systems. An initial feasibility study will examine the role of HOV priority and traffic restraint strategies utilizing IVHS technologies for demand management. This will then lead toward an operational evaluation of integrated demand management systems in the Denver metropolitan area, including a review of public acceptance of alternative strategies and approaches. Possible elements of the system could include HOV lanes, other transit priorities, parking management systems, graduated tolls or direct road pricing based on AVI.

Within the overall demand management study, selected subprojects would be specifically aimed toward the improvement of rideshare as a travel option. Two potential studies that have been identified as high priorities in this area are the development of a rideshare management and matching system, and the development of an HOV occupancy verification system. The rideshare management and matching system would provide a dial-up facility for rideshare requests, together with a computerized system for matching travelers with similar journeys and departure times. The HOV occupancy verification system would then be used to offer priority for rideshare vehicles at a number of control points, including ramp metering bypass lanes, toll facilities, and parking lots.

The demand management study will provide the opportunity to review a range of technologies and approaches in the Denver metropolitan area. The study will therefore identify the optimum system configuration and the most appropriate control strategies for different situations. This will ensure that traffic flow is maintained in the area, ensuring efficient use of the highway network. In addition, the rideshare improvement elements of the demand management study will greatly increase the appeal of this travel option. This will help to attract

travelers to ridesharing, reducing the number of private, low-occupancy vehicles. Further congestion reduction can therefore be anticipated as a consequence of this, with follow-on benefits in the areas of improved highway safety and reduced environmental pollution.

Iowa Department of Transportation

As outlined in the previous section, IVHS approaches aimed toward congestion reduction will be of only limited use in rural Iowan locations. Projects outlined for consideration by IADOT are therefore focused upon traveler information systems for the provision of traffic and weather data. Three principal areas have been identified, as follows:

- * long-range information broadcasting systems;
- * short-range hazard warning transmissions; and
- * highway condition and weather monitoring systems.

The first study proposed for consideration by IADOT is the investigation and application of long-range information broadcasting systems. These will be used to supply traffic information, weather reports and other pertinent data to rural motorists via in-vehicle units. The broadcasting systems could also supply similar data for display on terminals in the home or office, or at public information locations.

An initial element of the study will involve a review of alternative approaches applicable to long range data transmission. This will include investigation of technologies such as satellite paging and AM data systems. The review will also cover the requirements of the technologies in terms of data volumes, format and content. This work will lead to the selection of preferred approaches for use in Iowa. Equipment will then be implemented in the state, including data encoding and broadcasting equipment, and compatible decoding and display units for in-vehicle use. The utility and performance of the selected approaches will be assessed during an operational evaluation, drawing conclusions on wider system use and future development requirements.

The long range communications systems proposed for investigation in this study will potentially provide an important information transfer service in the State of Iowa. In Iowa, unlike some other areas, it may be impractical to introduce shorter-range systems such as the Radio Data System due to low population densities and consequent lack of existing communications infrastructure. This study will therefore investigate communications approaches more suited to Iowa's needs. These will be used to provide traffic information to motorists, helping to increase travel efficiency and reduce journey time. Advance warnings of weather or other hazards could also greatly improve the safety of rural highway travel in the state.

A related study outlined for consideration in Iowa would investigate and implement short-range hazard warning systems. These would use the same in-vehicle units developed previously, to display information on immediate hazards

to the driver. Warning information would be obtained from transmitters installed at the hazard location, transmitting over a range of a few hundred feet. Potential locations for the warning transmitters include roadway curves, maintenance activity sites or accident black spots. Transmitters could also be placed on moving hazards such as school buses or maintenance vehicles.

The study would involve the investigation of a range of technical options and issues for the communications element of the system. It would also be necessary to identify the messages required by the driver, and the locations at which transmitters should be placed. This work would then be used to develop an overall system design. The study would conclude with an operational evaluation of the system in the State of Iowa.

It is anticipated that the short-range warning system proposed for investigation in this study would be of significant value in preventing accidents. By providing advance warning of roadway or transient hazards, motorists will have more time to take required cautionary action. This will help to reduce accidents where motorists have insufficient time to react when confronted with an unexpected situation.

The final study outlined for consideration by IADOT will focus on highway condition and weather monitoring technologies. This will include systems capable of detecting rain, surface water, ice, fog, poor visibility and slickness. These will potentially be used to provide data to highway authorities to support decision making. The systems will also provide a further source of data for the long-range and short-range communications systems discussed above.

An initial element of the study will involve a review of the state-of-the-art in highway condition and weather monitoring systems. This will identify the capabilities of current systems, as well as technology development needs. The study will then seek to develop required approaches for monitoring physical highway and meteorological conditions. Finally, selected systems will be installed and integrated with the long-range and short-range information systems for operational evaluation.

The integration of highway condition and weather monitoring systems with the previously developed communication approaches will provide a further performance improvement in traveler information services. The ability of the systems to supply real-time highway and weather data will enable motorists to make considered control decisions and drive more safely. In particular, advance warning of ice, fog or similar hazards could be of significant value in preventing accidents.

Minnesota Department of Transportation

As described earlier in this chapter, Mn/DOT is currently in the process of defining its GUIDESTAR IVHS program. This will include identification of component projects and activities and an overall program. It is therefore inappropriate to outline potential projects for Minnesota DOT within this study, since this activity will be undertaken in detail in GUIDESTAR. GUIDESTAR will undoubtedly encompass a range of IVHS approaches in a major coordinated program,

and as such it would provide an important and welcome component of the ENTERPRISE initiative.

New York State Department of Transportation

Building on current and ongoing projects such as INFORM, VTIP and TBC, NYSDOT has already prepared ambitious IVHS plans in the field of advanced traffic monitoring and management. In particular, NYSDOT's proposals for enhancement and extension of the INFORM system will potentially result in one of the world's major examples of integrated traffic management and traveler information technologies. In itself, this work would make a substantial contribution to the ENTERPRISE program, while also providing a valuable test bed for a range of additional IVHS approaches.

Beyond NYSDOT's current proposals for IVHS activities based on existing projects, three further areas of research are outlined for consideration. These are:

- * radio paging systems for traffic information;
- * expert systems for traffic management and control; and
- * U.S./Canadian border applications.

The first study proposed for consideration in New York will investigate the use of radio paging systems for the provision of in-vehicle traffic information. This project could build on NYSDOT's existing experience of radio paging systems, gained through its membership of the TRANSCOM organization. However, the study would utilize a Trafficmaster-type system to provide traffic information, rather than the current technology adopted by TRANSCOM. Trafficmaster is described in Chapter 3 of this report, and is felt by the study team to represent a highly promising approach toward traveler information. In particular, Trafficmaster offers timely traffic updates and efficient use of data channels, making the approach worthy of U.S. evaluation within this study.

The implementation of a Trafficmaster-type system in New York would be undertaken in a phased approach. Hardware and software would need to be developed to support system use in the selected demonstration area. Traffic monitoring hardware would be installed at strategic highway locations for real-time data collection purposes. Other sources of data for the system, such as INFORM or the TBC network, should also be considered in producing the final system configuration. In-vehicle units would then be distributed to users, providing an opportunity to assess system performance during an operational evaluation.

The principal benefit of the Trafficmaster approach is the provision of in-vehicle information on highway congestion before drivers arrive at the affected site. This enables motorist to reroute to avoid incidents, thus reducing congestion and preventing secondary accidents. Air quality improvements may also be achieved as a result of system use.

The second study to be considered by NYSDOT is the investigation, development and application of expert systems for traffic management and control. These will be

used as advisors to operators of traffic control centers. Systems will be knowledge-based and will use information and models gathered from recognized experts and leaders in the appropriate fields of transportation engineering. Again, operation of the systems will potentially be supported by data gathered by the existing INFORM and TBC systems. Opportunities for the incorporation of pollution monitoring systems will also be investigated in the study. Following initial research and development work, the expert systems will be implemented for operational evaluation over a selected demonstration area. This will enable the performance of the system to be assessed, identifying opportunities for wider use and further development requirements.

The principal benefit of applying expert systems to traffic management and control will be in improving the efficiency of existing network utilization. This will result in reduced travel times and generally lower levels of congestion. By examining previous events stored in the knowledge base, and by learning from experience, the expert systems will provide maximum assistance to control center operators. The inclusion of pollution monitoring facilities and corresponding control algorithms will also help to improve air quality in polluted New York areas.

The third project outlined for consideration by NYSDOT will involve the application of IVHS technologies for traffic throughput improvement at U.S./Canadian border crossings. This would be a cooperative effort with the Canadian Province of Ontario. The study would review existing situations at border crossing points, identifying the problems to be overcome using IVHS approaches. Potential concepts to be investigated include electronic sealing of commercial vehicles and automatic processing and retrieval of customs documents. Selected approaches would then be further developed and resulting systems implemented for operational evaluation. Border crossing procedures could be greatly simplified as a result of this work, providing time savings for motorists and reducing administrative requirements for customs agencies.

U.S. Federal Highway Administration

As discussed in a previous section of this chapter, the principal role of FHWA in the ENTERPRISE program is likely to be related to overseeing and coordination activities. Unlike other proposed participants, therefore, specific projects and activities have not been defined for consideration by FHWA. However, FHWA may wish to participate more actively in selected projects within ENTERPRISE, in cooperation with other program members. This role would be similar to FHWA's joint responsibility in initiatives such as HELP, TRAVTEK and other current IVHS projects.

Ontario Ministry of Transportation

Three areas of IVHS are proposed for consideration by the Ontario Ministry of Transportation. These are listed below and further described in the following paragraphs. The three areas are:

- * cross border applications;

- * transit applications; and
- * low-cost, autonomous route guidance.

The first proposed study will be a cooperative effort with the New York State Department of Transportation. This will examine applications of IVHS technologies at U.S./Canadian border crossings, as discussed earlier in this section.

The second proposed area of activity will be based on the application of IVHS technologies to Ontario's transit fleets. As described in the previous section, the Province of Ontario contains some of the world's most advanced examples of transit fleet management and control. These include the systems installed in Toronto and Ottawa-Carleton. Transit-related activities undertaken within ENTERPRISE should therefore seek to exploit these opportunities to the maximum extent.

A number of activities could potentially be undertaken in developing transit-related IVHS approaches. One such project would involve the development of a vehicle journey data recorder. This would be capable of accepting and storing data from a variety of sensors, similar to the "black box" devices currently used to monitor airplanes. Though initially applied to buses in Ontario, the journey data recorder could be designed to permit future application to other vehicles in automated highway scenarios.

As a move toward automated vehicle control concepts, a number of transit driver assistance systems could be developed in Ontario. Potential technologies for investigation in this area include blind spot and vehicle overtaking warning systems, as well as reverse driving assistance. Again, systems initially developed for buses could subsequently be applied to other vehicles for automated control purposes.

Further potential transit-related research in Ontario could utilize existing fleet communication systems to transmit real-time data on vehicle loading and condition. This would be achieved by integrating passenger counting devices and component monitoring technologies with AVL systems. The approach would enable transit control center operatives to initiate control strategies in response to real-time data analyses. For example, it would be possible for transit operators to increase the number of vehicles in service when demand is high, or to remove vehicles from service when component malfunctions are detected.

A final activity suggested for consideration in the area of transit is investigation and application of automated passenger identification and payment systems. This would investigate technologies such as smart cards and automated passenger identification systems, identifying the preferred approach and most promising applications. The system would then be installed on a selected transit fleet for operational evaluation.

The activities described above have the potential to bring further improvements for Ontario's already highly-advanced transit systems. The various technologies will aim to increase the efficiency of fleet operations, providing cost savings for operators and improved control opportunities. Services will also be improved

for passengers, through increased reliability and the added convenience of systems such as automated payment. Overall, this should result in ridership growth, providing subsequent payback for the transit operators in terms of farebox revenue.

The third area of IVHS research proposed for Ontario is self-contained route guidance. This study will seek to develop and implement an in-vehicle system for the provision of routing directions, building on the work already undertaken in the Province. The system will utilize an autonomous approach, which is felt to provide a satisfactory solution for Ontario's navigation needs while avoiding the cost implications associated with a roadside infrastructure. An operational evaluation will be used to assess system performance and determine the benefits of the route selection approach.

Transport Canada, Transportation Development Centre

TDC is the final participant currently proposed for inclusion in the ENTERPRISE group. At the time of writing, TDC is understood to be evaluating proposals for the development of a Canadian national IVHS program plan. This could result in a number of TDC projects and activities that would be compatible with the overall objectives of the ENTERPRISE program. In addition, information provided by TDC personnel has identified several projects that are tentatively earmarked for joint cooperative work. These cover the following IVHS technologies and activities:

- * development and demonstration of a portable HELP unit, combining WIM, AVI and communications elements;
- * demonstration of electronic logbook downloading using AVI and onboard computers;
- * demonstration of driver advisory information uploading using AVI and in-vehicle display equipment;
- * electronic clearance at border crossings using AVI technology;
- * demonstration of traffic management approaches using AVI technology;
- * application of heavy vehicle multiplexing technology; and
- * development of active suspension technology for heavy vehicles.

8. STATE PROGRAMS

8.1 Introduction

This chapter considers issues concerned with the development of IVHS programs by individual participants in the overall ENTERPRISE initiative. The previous chapter of this report identified a number of potential participants for the program, including a review of their current and planned IVHS activities that are applicable to ENTERPRISE. This revealed that each of the proposed participants is at a different stage of planning for future IVHS activities. Mn/DOT, for example, has already commissioned the GUIDESTAR management study, which will define a series of projects and an overall timetable for the state. A similar study is currently being considered in Colorado, but has not yet been started. Other potential participants are at earlier stages of the IVHS program planning process.

Perhaps the most advanced of the proposed ENTERPRISE participants, in the context of developing a coordinated structure of research, development and operational evaluation, is the State of Arizona. By commissioning the MIDAS study, ADOT has prepared a program plan that defines the state's IVHS activities for the next decade and beyond. MIDAS will also represent Arizona's contribution to the broader ENTERPRISE program.

An important element of ENTERPRISE will therefore be for other proposed participants to develop similar programs for coordinated IVHS research. These need not be to the same scale as the MIDAS initiative, since different participants will require individual programs of different magnitudes. Each program should set out a structured agenda of well-defined IVHS projects, in accordance with the organization's particular needs and interests. This will ensure that the ENTERPRISE participants carry out a logical progression of research, development and operational evaluation activities, aiming toward clearly specified goals.

Before these individual programs are developed, however, two activities can be undertaken that provide a valuable contribution to the program planning process. The first of these is a review of the attributes of the participant and its suitability for particular IVHS technologies. The review should focus on factors such as previous experience in highway transportation research, traffic conditions and highway environments, geographical situations and weather and climatic conditions. This will serve to identify the types of IVHS technologies that are most suitable for investigation by the participant. The review can also be used to support and justify the development of an internal IVHS program, by revealing the problems that will be targeted. Finally, the review will provide evidence of a sound approach toward IVHS development when funding requests are submitted.

The second activity that could be usefully carried out by ENTERPRISE participants is a review of testing locations and field sites for operational evaluations. This will reveal the extent to which participants can assess IVHS approaches in real-life situations, and the types of technologies that can be examined.

Therefore, the review will demonstrate that realistic evaluations can be performed, providing further support for project proposals and funding requests.

The State of Arizona has recognized the importance of these activities in developing its MIDAS program plan. Investigations into the suitability of Arizona for IVHS and the availability of test sites in the state were therefore carried out in the initial MIDAS development study. Other members of ENTERPRISE may wish to undertake or commission similar work in their own IVHS program development efforts. Findings of the Arizona study are therefore presented in this chapter for illustrative purposes, for the benefit of the other potential participants.

Following this introduction, the remainder of this chapter is divided into two further sections. The first of these provides a concise summary defining why the State of Arizona is an appropriate location for an IVHS program. There are many current and pending studies in Arizona that can be utilized within the state's IVHS initiative to provide significant advantages. These advantages will include cost savings, manpower saving, fast-track results and rapid personnel development. Other ENTERPRISE participants could similarly benefit by incorporating existing work into future IVHS activities.

Section 8.3 reviews some of Arizona's facilities that can be used for testing IVHS technologies. Arizona is able to provide a number of effective locations that will be invaluable for testing IVHS reliability and assessing operational accuracy. Some of these may be unique to the state, while others may also be available to other ENTERPRISE members. Needs for testing and integration are also considered, in parallel, as existing initiatives that can be integrated into the IVHS program will also provide a useful testbed for other IVHS technologies.

8.2 Suitability of participants for IVHS

There are undoubtedly a large number of locations throughout the U.S. where research, development and demonstration projects could be undertaken, and an equally large number of IVHS approaches for investigation. Potential ENTERPRISE participants should therefore seek to define their particular attributes and identify the most suitable corresponding areas of IVHS. Further discussion on the suitability of the State of Arizona for IVHS-related activities is presented in the following paragraphs as an illustration of this task.

One of the key points in favor of proposals for IVHS research is recognized leadership and experience in the field of advanced transportation technologies. Arizona, for example, has led the HELP program since its inception in 1983, and is currently administering and managing the program as it enters the vital Crescent Demonstration phase. HELP has made substantial progress in the areas of AVI, WIM, AVC, onboard computers, and communications and processing equipment. The program is acknowledged as a keystone of the national IVHS initiative. Management of the HELP program is a complex process, requiring the administration and coordination of activities undertaken by public and private sector participants in the 14 HELP states, as well as consultants and other contributing organizations. Many of the other prospective ENTERPRISE participants are

involved in HELP or similar multi-state initiatives and can therefore call upon their experience in their own internal IVHS efforts.

Equally important as this recognized leadership and experience will be demonstrated commitment to the IVHS concept. The State of Arizona's various projects in the recent past and at present represent a major investment in advanced transportation technologies. In particular, Arizona's leadership of the HELP program has required a substantial input in terms of state-funded staff time and equipment, including internal resources and HPR funding. This indicates that Arizona is prepared to invest in its belief in IVHS technologies, rather than simply seeking to fund the initiative through federal sources alone. Through projects such as INFORM and GUIDESTAR, other potential participants have already demonstrated a major commitment to IVHS which will be essential for the success of the coordinated ENTERPRISE effort.

The availability of test sites is a further factor for consideration in developing state IVHS programs. Arizona is fortunate to have a number of highly advantageous in-state locations that will provide ideal test sites for IVHS technologies. These include several automobile manufacturers' proving grounds, which have previously been used by ADOT within the HELP program to perform evaluations of AVI systems. Other states may contain similar facilities and existing cooperative links with commercial organizations which will be valuable in IVHS development and testing activities. The freeway management and traffic control systems in Phoenix and Tucson will provide useful facilities for the investigation of urban IVHS approaches. States such as Colorado, Minnesota and New York will also benefit from the operation of traffic monitoring and management facilities in their ongoing IVHS-related activities.

Further, testing locations available in Arizona will include several sites on the HELP Program's Crescent Demonstration Project route. These will be equipped with AVI, WIM and AVC, and will be linked via an integrated data communications and processing system. As well as providing facilities for the evaluation of a range of IVHS concepts and approaches, the use of Crescent sites will permit ADOT to fully coordinate the state's IVHS initiative with the ongoing HELP program. This will ensure that the results of the two efforts are transferable between one another, and that HELP provides a springboard for diversification into new areas of IVHS. Coordination in this manner will also enable the State of Arizona to carry out multi-purpose research efforts, in areas such as road-vehicle communications, offering maximum efficiency in the use of funding sources. Other states should therefore identify similar opportunities for efficient IVHS advancement by building on and integrating existing projects and activities.

In addition to specific research facilities and test sites, ENTERPRISE participants will also be able to capitalize on their freeway systems for assessment of IVHS technologies. In Arizona, much of the freeway network has only recently been constructed, and is therefore comparatively uncongested. As a result, it will be possible for Arizona to investigate IVHS approaches that seek to improve the safety and efficiency of free-flow traffic and prevent congestion, as well as systems that aim to disperse or reduce incident-related congestion. Other ENTERPRISE states may experience higher congestion levels, and may therefore be more interested in examining IVHS technologies that provide some measure of immediate congestion relief. In the State of Iowa, meanwhile, systems

that can improve travel on rural highways will be most appropriate for investigation.

Geographic, environmental and climatic conditions should also be considered by ENTERPRISE participants in developing IVHS program plans. The State of Arizona experiences a wide range of conditions across its seven recognized climatic zones, in which several alternative IVHS technologies can be evaluated. States such as Iowa and Minnesota experience particularly harsh winter conditions, and will therefore be appropriate areas for investigation of IVHS approaches that seek to improve safety during poor weather.

ENTERPRISE participants should also be able to call upon a range of experienced personnel to participate in their proposed IVHS programs. In Arizona, many suitably qualified personnel are employed with ADOT, principally within the Transportation Planning Division and the Arizona Transportation Research Center. Arizona is also fortunate to have university staff available with a strong research background, including the Arizona State University and University of Arizona. Other ENTERPRISE participants contain similar research facilities and personnel with strong experience in advanced transportation research. Such experience within state government and academia, combined with private sector participation, will ensure that ENTERPRISE activities are undertaken from a position of substantial prior experience, offering maximum benefits in the shortest possible timeframe.

8.3 Testing and evaluation sites

The identification of suitable sites for testing and evaluation of IVHS technologies will be a further beneficial activity in developing state IVHS programs. This will provide an indication of existing opportunities for assessment of IVHS approaches without requiring extensive new construction. It will also help to identify the types of IVHS technologies that can realistically be evaluated. This section outlines testing and evaluation sites to be used for the State of Arizona's MIDAS program, as an illustration of the type of facilities that may be available in other ENTERPRISE locations. Potential test sites and facilities in Arizona include:

- * the Phoenix Freeway Management System;
- * Crescent Demonstration sites;
- * Phoenix freeway test sections; and
- * motor corporation test tracks.

Further details on the possible use of these facilities are presented in the following paragraphs.

The Phoenix Freeway Management System

The Phoenix Freeway Management System has been designed to provide a comprehensive, advanced freeway traffic control system. The integrated system is intended to maximize utilization of the physical capacity, minimize the adverse effects of breakdowns during peak periods and provide an optimum response to freeway incidents. The system will also be capable of providing motorist information, a means of informing motorists of alternative routes, and the ability to provide a single management contact point for a variety of agencies.

The completed system will consist of the following elements:

- * a central control computer;
- * a ramp metering system;
- * CCTV monitoring;
- * loop detection;
- * signal integration;
- * HAR;
- * variable message signs; and
- * a comprehensive, high-capacity communications system.

Similar traffic management systems also exist or are currently planned among other proposed ENTERPRISE participants, including Colorado, Minnesota and New York. These contain many of the same elements as the Arizona system, each of which can be exploited to varying extents by the proposed IVHS activities. The central computer controlling the integrated signals and various traffic monitoring systems will form a valuable information source for a range of ATIS. The freeway control center computer will contain large amounts of real-time traffic data derived from loop detectors or other systems. These flow and occupancy data can be used to calculate approximate journey times based on vehicle speeds in the initial stages of an externally linked route guidance system.

In order to achieve maximum benefits from systems that utilize some form of in-car receiver, systems can be integrated with existing variable message signs to provide a secondary means of communicating information to the driver. Used in conjunction with loops, the CCTV monitoring will provide incident detection and appraisal for advanced incident management. It could in future also provide the necessary input for an automated video detection system such as the Minnesota Autoscope system.

The communications medium of the Phoenix Freeway Management System consists of a pair of fiber optic single-mode cables with nodes at approximately five-mile intervals. This will be valuable for transmitting information to and from test

sites in the freeway corridor. Other ENTERPRISE participants will similarly be able to use existing or proposed communications networks. These will allow early implementation of a variety of IVHS component trials in parallel with identification of the optimum data transmittal medium. An example of an IVHS element that may take advantage of this approach is two-way vehicle-roadside communication, used for externally-linked route guidance and monitoring of individual trip times.

Crescent Demonstration sites

The HELP program, for which Arizona is the lead state, has been heralded as one of the nation's premier IVHS projects. This research and development program has centered on three technology areas: WIM, AVC, and AVI. These have been applied in the IVHS area of FMCS primarily to improve weighstation and port-of-entry operations, to assist government activities concerning truck traffic, and to increase the convenience of interstate truck travel.

Arizona has been heavily involved in the HELP AVI research and development program. ADOT conducted the track testing of AVI technologies at the Ford Motor Proving Ground at Yucca, Arizona. These evaluation trials eventually led to the development of a generic AVI specification that has been adopted for the Crescent Demonstration. This advanced research in the area of vehicle-to-roadside communication technology will be invaluable for future IVHS development and is expected to form the starting point of a number of advanced communications projects.

The HELP program has now reached the demonstration stage. Fourteen states, a Canadian province and a U.S. port authority are involved in this IVHS demonstration. Forty equipped sites are involved, ranging south from British Columbia to California and then east into Texas. About 5,000 commercial vehicles will be equipped to participate in this trial. Arizona has six sites along I-10 running east-west through the state. These Crescent Demonstration sites are located at Ehrenberg port-of-entry, Tonopah, South Phoenix, Marana, Benson and San Simon port of entry, as shown in Figure 8.1.

The Crescent Demonstration installations consist of two basic types:

- * monitoring locations, which are remote sites equipped with WIM/AVC and/or AVI equipment, and only collect data; and
- * weighstation/port-of-entry sites, which provide operator work areas and access to collected data on site.

Both types of site are connected to a state-level computer linked to a regional host system. The connections are implemented using modems and telephone lines. The monitoring sites store traffic information and are polled by dialing from the state computer for downloading data at periodic intervals. The weighstation/port-of-entry sites are connected to the Crescent state computer via dedicated telephone lines. Data will be transferred through these dedicated lines both by state computer polling and interactively between the state computer and the remote port-of-entry computer.



Figure 8.1 Arizona Crescent Demonstration Sites

Further development of AVI equipment under the HELP program has already been committed, with Federal funding under the new IVHS appropriation. Perhaps the most important area of future work is the development of a high data-rate beacon-based AVI system. The work will consist of the development of such AVI specifications which can be used to obtain prototype equipment. Extensive testing, evaluation and refinement of the prototypes will result in a refined generic specification for advanced, two-way, high data-rate beacon systems. This specification is well suited for adoption as the vehicle-to-roadside communication element of full IVHS. It will also provide an invaluable tool for the early implementation of IVHS technologies and systems that rely on such a link.

The Crescent Demonstration sites will provide six well-equipped operational testing locations, particularly in respect of the AVI beacons described above. The sites will also be able to provide remote traffic and system performance monitoring facilities via their on-line data links. The rural, interurban locations of these sites will provide contrasting traffic patterns and differing operational conditions in comparison with those operational test sites to be located in metropolitan areas.

While other ENTERPRISE participants will not have access to Crescent sites, they may contain similar facilities that can be used within their IVHS programs. For example, some of the proposed ENTERPRISE members are also involved in the work of the Advantage I-75 group. This could result in the installation of facilities and equipment having many characteristics in common with the Crescent sites. In addition, the increasing introduction of AVI technology for electronic toll collection, particularly in the State of New York, will provide further opportunities for integration within the ENTERPRISE program.

Phoenix freeway test sections

A further option to be considered by ENTERPRISE participants is the use of public highway sections for evaluation of IVHS technologies. In Arizona, three operational testing locations have been selected for MIDAS testing and development in the Phoenix area. The sites chosen utilize stretches of the new freeways within the city. The selections represent three radically different environments; a tunnel section, a straight parkway section and a curved freeway section. The locations are I-10 (Papago Freeway) below Central Avenue; Squaw Peak Parkway between Indian School Road and Bethany Home Road; and the curved stretch of the East Papago Freeway between 44th and Van Buren Streets.

The Papago Freeway tunnel stretches for half a mile between 3rd Avenue and 3rd Street, as shown in Figure 8.2. The tunnel, designed by Ammann and Whitney of New York City, in association with Sverdrup Corporation of Washington, was constructed during 1988-89 using 95 percent federal funding. The physical construction cost totalled \$55 million with an additional \$20 million for electrical and mechanical components required to complete the advanced design. The construction is of the cut and cover type utilizing nineteen 150-foot wide by 250-foot long bridge sections. The decks are covered with soil to form a park above the tunnel. Central Avenue bridges over the top of the park.

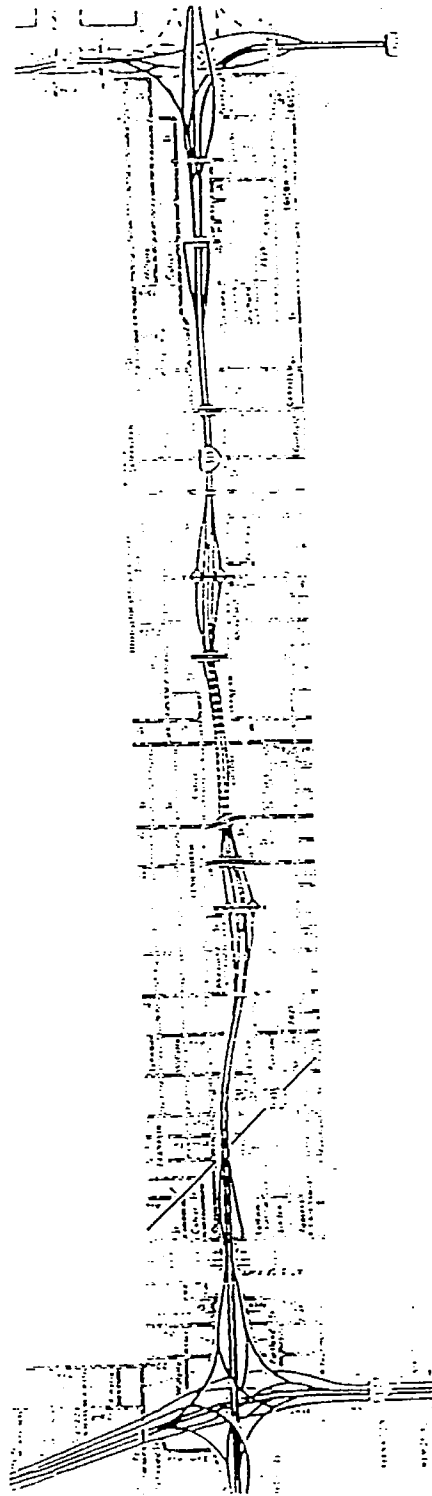

Figure 8.2 Papago Freeway Tunnel test location

The advanced equipment already installed in the tunnel consists of 18 video cameras, numerous loop detectors, emergency telephones and eight 750 hp ventilation fans. The loop detectors continuously monitor traffic conditions within the tunnel and relay the information back to an operator in a control room located below Central Avenue. The operator can then verify traffic conditions and activate lane signals and message boards as appropriate. The quality of the air in the tunnels is continuously monitored and will provide a useful laboratory for assessing the environmental impacts of IVHS implementation.

The tunnel layout is shown in cross section in Figure 8.3. There are four lanes in each direction eastbound and westbound with a pair of central mass transit lanes. The mass transit lanes will make an ideal test track which can be used for initial demonstration during off-peak times. A further advantage of these central bus lanes is the option of direct access through a bus terminal, removing the need for researchers to cross the highway.

The electronic surveillance and monitoring equipment will be utilized for cross checking and verification of results from IVHS equipment being tested at this location. The new control room located below Central Avenue will be used to house the equipment associated with the IVHS implementation and testing. The length of the test section can also be extended as required at either end of the tunnel. To provide a more varied facility the test section can be extended to run between 17th Street and 19th Avenue. The section will then include diamond intersections at 7th Avenue and 7th Street, allowing a greater variety of sophisticated central technologies to be tested.

Participation in Arizona's program by the City of Phoenix will allow use of the second test section, which lies on a newly-constructed section of city highway. The section chosen is a two-mile length of Highway 51, the Squaw Peak Parkway, running north-south between Indian School Road and Bethany Home Road, shown in Figure 8.4. The road section also passes below an intermediate intersection close to Camelback Road. Intersections with Bethany Home and Indian School will provide for the implementation and evaluation of a variety of IVHS technologies for traffic monitoring and information transfer which will be required during the course of the MIDAS program.

The third road section identified in Arizona has not yet been completed. It is an eastern continuation of the Papago Freeway between 44th Street and Van Buren Street, also shown in Figure 8.4. A large sweeping curve will bypass Papago park and provide a suitably different road environment for automatic steering system trials. This section of road has the additional advantage of being available for IVHS testing prior to its public opening. Other sections of Phoenix's extensive, new freeway system may also be selected for this prior-to-opening testing, according to detailed timing requirements of the eventual test program.

Overall, Arizona has identified a number of freeway sections that can be used within its MIDAS IVHS program. Similar opportunities may also be found among other ENTERPRISE participants. This could include existing highway or tunnel sections, as well as proposals for future construction. Participants should therefore seek to identify these locations, in order to take full advantage of the opportunities they offer for implementation of IVHS approaches.

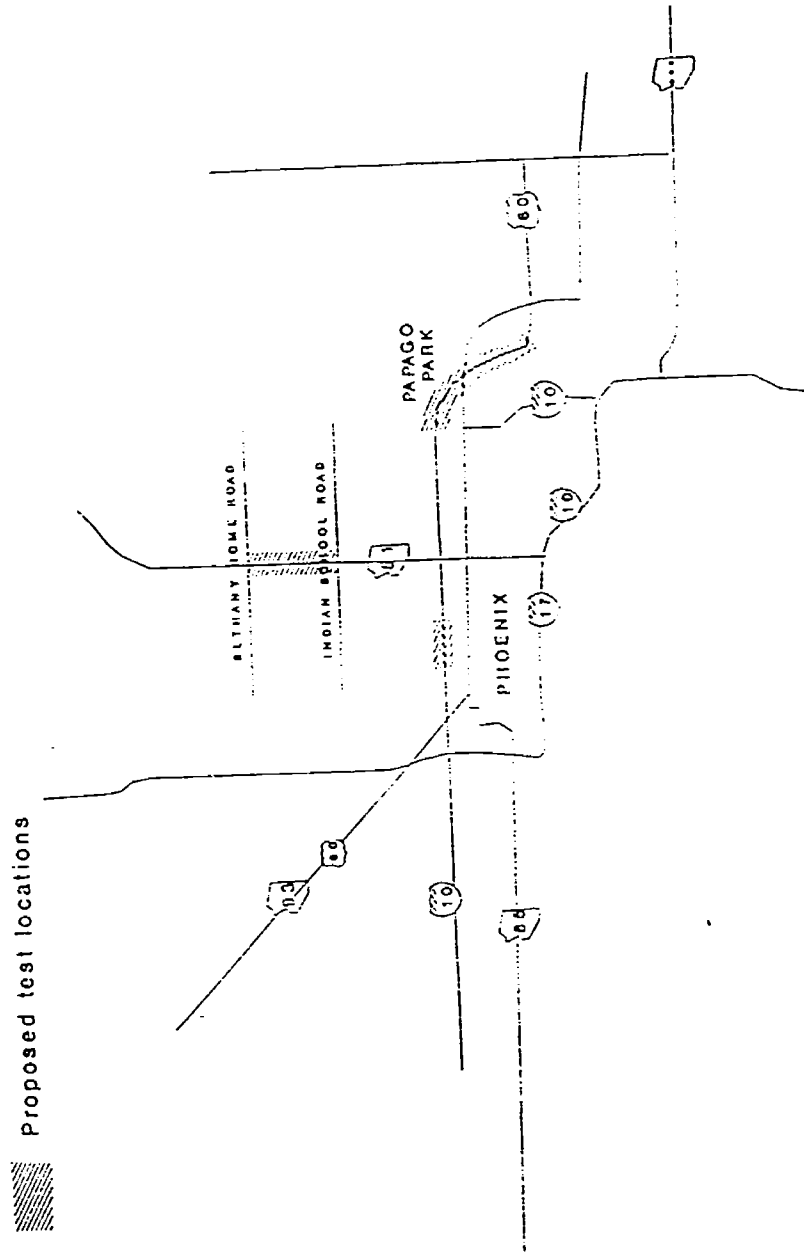

Figure 8.4 Test Locations in Phoenix

Motor corporation test tracks

Facilities operated by private firms with established links to the public sector will provide further opportunities for testing and evaluation of IVHS technologies in the ENTERPRISE program. In Arizona, for example, significant benefits could result from the use of facilities provided by motor corporations. Arizona's extensive open spaces and extreme climatic conditions have made the state a popular location for automobile test tracks. Four major motor manufacturers have such tracks within the state. These are Ford, General Motors, Nissan and Chrysler.

Use of these test tracks would provide the ability to test a wide variety of different technologies under highly controlled conditions. Test tracks will be used within MIDAS for assessing prototype system performance during early development phases. Tracks will also be used extensively in cases where such tests could endanger the public if carried out on an open highway. These tests could involve the use of high vehicle speeds or sophisticated, automatic control technology.

Arizona already has experience of the facilities offered by the Ford test track located in Yucca through the HELP program. HELP AVI testing carried out at this site sought to evaluate the operation of various AVI technologies at different vehicle speeds and with tags located at different positions on the vehicle. Other ENTERPRISE participants may have established similar, cooperative links with private sector organizations through previous or ongoing work. Collaboration such as this, between state and private industry, is expected to play an extremely important part in the overall success of the ENTERPRISE program. Developing a good working relationship with the private sector is therefore very desirable and has the potential to provide many mutual benefits for the states and industry alike.

8.4 Summary

The organizations proposed for inclusion in the ENTERPRISE initiative are all at different stages of the IVHS program planning process. A major element of the ENTERPRISE program will therefore be for each participant to formulate a clearly defined agenda for IVHS research, development and operational evaluation activities. This task has recently been undertaken by the State of Arizona, while states such as Minnesota and Colorado are currently in the process of implementing or preparing IVHS planning studies.

In developing internal IVHS program plans for the ENTERPRISE initiative, a significant contribution could be made by performing a review of the characteristics and attributes of the various participants. This would focus on existing IVHS projects and activities, opportunities for testing and evaluation of IVHS technologies, cooperative links with the private sector and other pertinent issues. The State of Arizona has undertaken these activities within its MIDAS development study. The results of this work could therefore be used as a model for similar activities by other ENTERPRISE participants, if required.

9. PROGRAM ACTIVITIES

9.1 Introduction

This chapter outlines a typical state-level program to be undertaken as part of the broader ENTERPRISE effort. This is based upon the MIDAS initiative developed for the State of Arizona. The intention is to provide an overview of the structured approach adopted by Arizona, which can serve as a model for similar program developments among ENTERPRISE participants, if required. Projects such as the Minnesota GUIDESTAR management study are already beginning this program planning process for other potential members of the group.

The justification for a coordinated IVHS program plan has two separate, though strongly related, components. The first of these relates to the suitability of the state for performing a range of IVHS research, development and demonstration activities. This raises the question: What can the state bring to IVHS that other potential locations may be unable to offer? This question has effectively been answered in the previous chapter of this report, using Arizona as an illustration, and is not considered further here.

The second area of justification is to consider the benefits that will be derived from a coordinated IVHS program. The question in this case is: What will the participants get out of the initiative? This is an important consideration since it will demonstrate that the research is being undertaken with specific benefits and objectives in mind, including economic development and gains to highway users. Policy makers will only be inclined to support proposed IVHS initiatives when they can envision the substantial benefits that will result.

After this introduction, Section 9.2 presents a general discussion of the benefits of implementing an IVHS program in the State of Arizona. This focuses on issues such as economic growth, commercial prosperity and stimulation of other research activities in the state. It is expected that other participants would obtain similar benefits through involvement in the ENTERPRISE program. The following section goes on to illustrate the proposed structure of the MIDAS initiative, including definition of its component research, development and operational evaluation activities. The final section of the chapter examines the technologies and benefits that will result from the MIDAS program. The benefit assessment in this section is more specific than the earlier general discussion, examining the utility of each newly-developed technology in areas such as traffic congestion, safety and fuel savings.

9.2 Benefits of IVHS

This section provides an overview of the potential benefits of IVHS research, development and implementation for members of the ENTERPRISE program. For illustrative purposes, the review focuses primarily on gains for the State of Arizona identified through the MIDAS development study. However, it is expected that many of these improvements will also be replicated for other ENTERPRISE

participants as a result of their internal IVHS efforts and the broader cooperative program.

While the previous chapter outlined the suitability of Arizona as a location for IVHS research, development and operational testing, there must also be sufficient benefits to make the initiative worthwhile for the state. This will be equally true for the other ENTERPRISE participants. The ENTERPRISE program will undoubtedly require a major investment in terms of staff time, equipment, administration and direct funding. The IVHS program and its resultant technologies should therefore be seen to have the potential to result in a payoff which comfortably exceeds this total investment, even in the short to medium term.

Through the proposed IVHS initiative in Arizona, the public sector (including state and city governments) will gain valuable hands-on experience of IVHS technologies. In addition, private sector involvement in IVHS activities has the potential to stimulate commercial development in the state. High technology firms can be expected to move into the state to exploit these new opportunities. This will provide significant employment benefits for current residents and migrants over the next two decades. Overall the growth of the IVHS industry can be expected to have far-reaching impacts in strengthening the Arizonan economy and increasing the standard of living. Other ENTERPRISE participants undertaking comparable IVHS programs will experience similar gains to those envisioned in Arizona.

The ENTERPRISE program will also serve to underline and enhance the position of its participants at the leading edge in advanced transportation technology. The recognition that will accompany this position of leadership can be expected to have further significant benefits. The widespread recognition of a dynamic approach toward IVHS will assist in encouraging commercial prosperity in all sectors of the economy, not just the transportation, electronics and computer industries. In addition, the growth of research and development in IVHS is expected to stimulate other research activities. As a result, the ENTERPRISE participants could become widely acknowledged as leading centers of excellence for advanced technology research. This will significantly enhance the reputation of their commercial corporations, as well as universities and other public research organizations.

The IVHS program plan already developed for the State of Arizona contains initial activities in well-advanced technology areas. This will ensure that necessary research, development and testing of these technologies can be undertaken at an early date. As a result, the IVHS program plan will lead to near-term implementation of advanced transportation technologies within the Arizona highway environment. These will provide immediate benefits in combatting the state's growth-related problems of traffic congestion, traffic accidents and air quality. Development of IVHS program plans among other ENTERPRISE participants should therefore similarly include near-term projects, providing immediate evidence of the benefits of IVHS.

The MIDAS program plan also gives attention to longer-term, high payoff technology areas, such as vehicle and highway automation concepts. These technologies have the potential to bring about dramatic improvements in the

highway environment, through increased capacity, safety and efficiency, and improved air quality. Other state programs would also contain longer-term goals based upon anticipated technology developments, in accordance with the particular needs of the ENTERPRISE participants. The coordinated approach advocated in the ENTERPRISE program will therefore ensure that these benefits are fully realized in the minimum time period.

Overall, therefore, substantial benefits can be anticipated as a result of involvement in the ENTERPRISE program. The research activities will confirm the position of the participants at the leading edge in advanced transportation technology. The program will support commercial prosperity and a continued high standard of living, as well as enhancing the reputation of universities and other research organizations. Technologies and systems developed as a result of the IVHS program also have the potential to achieve radical improvements on North American highways in terms of efficiency, safety and air quality. The ENTERPRISE initiative is taking a lead in proposing a multi-state and multi-national coordinated program, and its contributors will therefore find themselves in a position to command the full benefits of IVHS.

9.3 The MIDAS program

The remaining sections of this chapter provide an overview of the IVHS projects and activities to be pursued through Arizona's MIDAS IVHS program. This is intended to illustrate the structured approach used by Arizona that other ENTERPRISE participants may wish to adopt in finalizing their internal IVHS programs. Minnesota's GUIDESTAR management study and Colorado's proposed IVHS master plan project will also result in similar coordinated programs. Ultimately, it is envisioned that the contribution of each ENTERPRISE participant will be represented by such an approach.

Activities recommended for Arizona have been selected to take full advantage of the strengths and unique situations which exist in the state. These aim to focus resources in those areas which offer the greatest potential for making significant advances in the transportation environment and satisfying the state's needs. A similar rationale should be adopted by the other ENTERPRISE members in their program development activities.

Arizona's MIDAS program is based around a structured proposal for three phases of research, development and demonstration activities. The first of these is expected to begin in the early part of 1991, and will be substantially based around technologies and systems that are already existing or under development. This will ensure that the program leads to near-term implementations in Arizona, providing rapid benefits for the state. Phase One activities will be focused primarily on communication and information technologies, with close links to the ongoing HELP AVI research effort in which Arizona and other proposed ENTERPRISE participants are involved.

Arizona's Phase Two work from mid-1993 will build upon that undertaken in Phase One. In Phase Two, however, the IVHS approaches developed initially for driver information and communications will be enhanced to provide elements of vehicle

and highway automation. These will be used primarily to provide backup facilities to enhance driving safety, with manual control being retained by the driver under most circumstances.

The third phase (1997-2000) will seek to further enhance the technologies and systems developed in Phases One and Two. The objective of Phase Three will be to achieve a much greater degree of automated control, substantially relieving many conventional driving tasks. The ultimate goal of this phase is the demonstration of a fully operational AVCCS on the Phoenix freeway network, capable of offering levels of service and security virtually undreamed of in the current century.

Representatives of the proposed ENTERPRISE participants may find it useful to review the approach adopted toward IVHS advancement by the State of Arizona, as an input to their own IVHS planning efforts. Further details on the MIDAS program are presented in the following sections of this chapter, divided into the three phases of research discussed above. Benefits of the proposed activities are discussed in the final section of the chapter.

9.4 Phase One projects and activities

The projects and activities proposed for inclusion in Phase One of Arizona's MIDAS program cover a period of three years, from the start of 1991 to the end of 1993. The main emphasis during this time will be placed upon communication and information systems. However, preliminary research will also be undertaken into the technologies required to support the automation concepts of Phases Two and Three. The Phase One program is presented graphically in Figure 9.1, with further details of individual projects and activities presented in the following paragraphs.

Project #1 - Management development study

The first project of Arizona's program is the initial management development study. This has been divided into three distinct elements, referred to as Projects #1A, #1B and #1C. The first of these, Project #1A, involved preparation of the initial feasibility report. This led to the development of the MIDAS program and definition of its component projects and activities. Project #1B has subsequently built upon the feasibility study report through the preparation of this concept development document. It is intended that this second report will be used to draw together ENTERPRISE program participants from the public and private sectors, representing Project #1C of the management development study.

Project #2 - Autonomous vehicle navigation

The second project of Arizona's Phase One MIDAS research effort will involve adaptation of an existing IVHS technology for use in Arizona. An autonomous in-vehicle navigation system developed within the AMTICS/RACS projects will be implemented and evaluated in the state, through a cooperative agreement with the

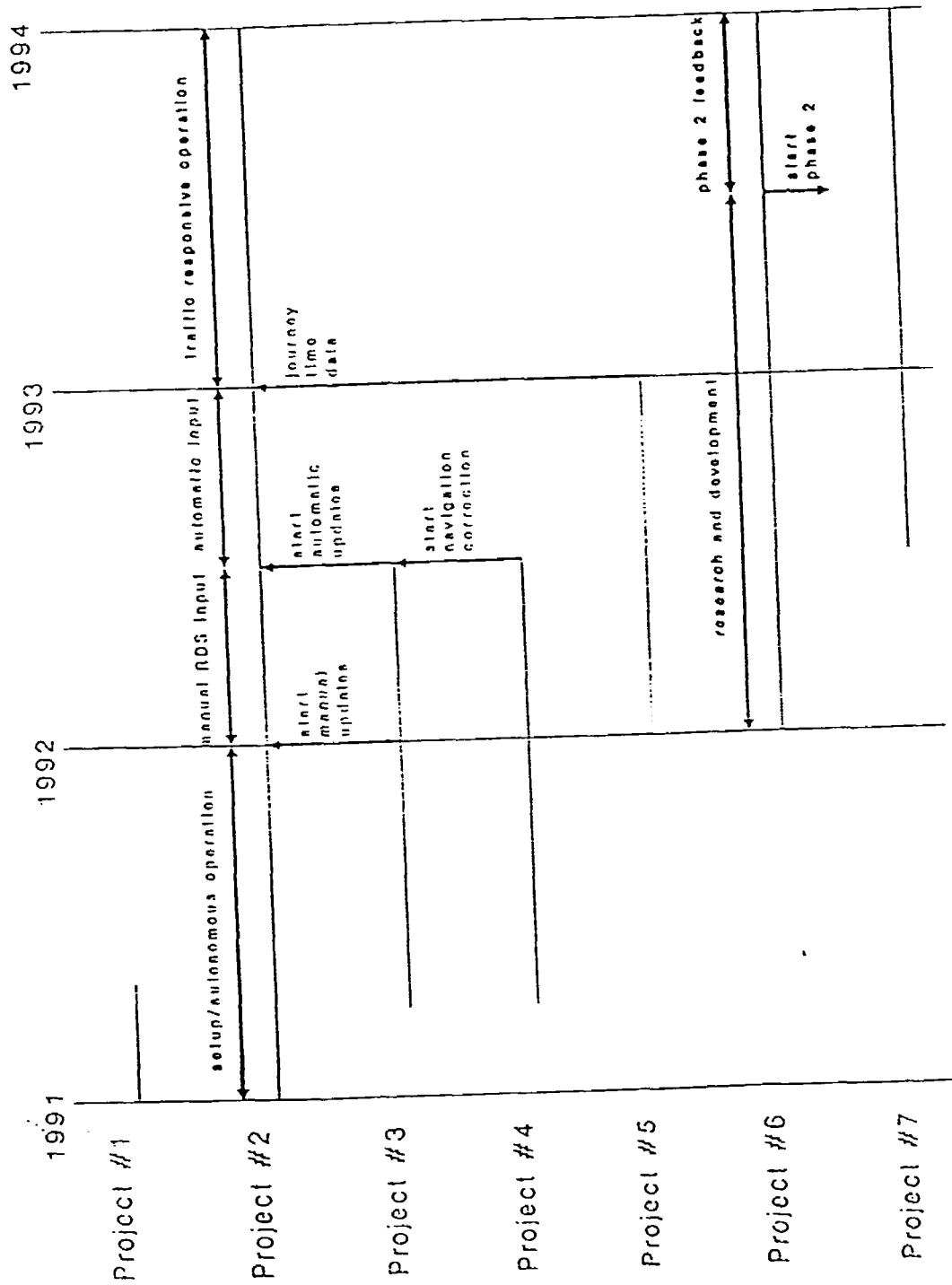

Figure 9.1 Phase One schedule

automobile manufacturer and system developer. These existing autonomous navigation systems utilize a combination of dead reckoning and direction heading sensors to continuously calculate a vehicle's location, relative to a known starting point. An in-vehicle computer stores a map database of an area's surface streets, tracking the vehicle as it moves through the network. The street map is shown to the driver on a color display unit in the vehicle, which also displays and continuously updates the location of the vehicle.

In addition to providing details of the street network and vehicle location, these navigation systems contain several further desirable features that make them worthy of investigation. The in-vehicle computer can be used to select and highlight a preferred route to a specified destination, based upon historical impedances of the various alternatives. As the vehicle follows a recommended route, the driver can be instructed when it is necessary to make turning maneuvers, according to the system's dead reckoning calculations. The system also incorporates a yellow pages type of function, which enables the driver to locate a range of services and facilities recorded in the computer database.

In order to implement and evaluate the autonomous navigation system in Arizona, a database of the street network in the testing location will need to be developed. This will provide, in coded form, the lengths and historical impedances of links in the network, together with other data such as the locations of various services. Test sites being considered for the autonomous navigation system are the surface street systems in the cities of Phoenix and Tucson. The coding work will be based on existing digital mapping databases of the Arizona DOT, with the resulting network database being incorporated into the system's in-vehicle computer. This will then enable the utility of the system to the driver to be evaluated in various modes of operation, as follows:

- * map and vehicle location display only;
- * map and vehicle location display, together with preferred route identification;
- * map and vehicle location, preferred route identification and routing instructions; and
- * routing instructions only (no map display).

For each of these modes of operation, several factors will be investigated in Arizona. These include:

- * the ability of the driver to select or follow a route;
- * the comprehensibility of the display or routing instructions;
- * the extent to which time and distance savings can be achieved through use of the system;
- * the vulnerability of the system to nonrecurrent congestion;
- * the accuracy of the location calculations; and

- * human factors and safety considerations concerning use of the system.

The AMTICS/RACS equipment with sophisticated processing and full color graphics capabilities is considerably more advanced than the Bosch-Blaupunkt Travelpilot system being evaluated in PATHFINDER. The results will therefore be of significantly more relevance in evaluating the potential of advanced ATIS equipment for the 1990s.

The time period for this study is shown in Figure 9.1. The project would commence in early 1991, with the first year involving the coding of the network database, commissioning and initial operation in autonomous mode. Subsequent projects in Phase One of the program will add incremental elements of real-time traffic information, as discussed below.

Project #3 - Traffic information broadcasting

Project #3 of Arizona's MIDAS program will investigate and implement a traffic information service based upon RDS. This will be used to broadcast traffic information in standardized, nonproprietary digital form, inaudibly carried on conventional FM broadcasts. The information will then be decoded by RDS-equipped radio receivers. In order to implement an RDS service, the following work will need to be undertaken in Arizona:

- * development and coding of standard lists of traffic messages and locations for broadcast data transmission;
- * development and adaptation of RDS receivers to store the message and location lists for encoding purposes; and
- * coordination with radio broadcasters to implement the RDS facility on FM transmissions.

Locations selected for introduction of the RDS service will be related to those adopted for the navigation system in the previous project. Sources of data for the transmission of RDS messages will include the following:

- * information collected by freeway management and traffic control systems;
- * journey time and traffic flow information monitored at HELP sites by mainline AVI, WIM and AVC devices;
- * advance knowledge of highway construction, maintenance or other special events affecting traffic; and
- * reports generated by the state patrol, DOT vehicles, and members of the public via cellular telephones.

Following the establishment of the RDS broadcasting facility, the system will be used to provide traffic status information for the onboard navigation system implemented in the previous MIDAS project. This will enable the navigation system to make real-time adjustments to routings in response to incidents or

traffic congestion. Initially, the approach used to update the computer database will be manual entry using a microcomputer keyboard. The driver will review the RDS information displayed by the in-vehicle receiver, appropriate details of which will be automatically downloaded into the navigation computer.

A subsequent stage of the project will seek to automate the process of entering the traffic data into the broadcast data system. This will involve the development of an interface between the Freeway Management System and the traffic status terminal of the RDS broadcasting equipment. Traffic information broadcast using RDS will then automatically be considered in the assessment of alternative route options, without the need for any interaction with a control center operator.

In addition to providing traffic information for utilization by the navigation system, there are several further applications that can be supported by RDS in Arizona. Temporary variable message signs interfaced with RDS receivers could be located at highway sites to warn of transient hazards or maintenance. The signs can then be activated and messages changed remotely using RDS transmissions, removing the need for hard-wired communications. RDS can also be used to transmit messages specifically for receipt by transit, police or emergency service vehicles, to assist in fleet control activities.

Evaluation of the RDS traffic information broadcasting service integrated with onboard navigation in Arizona will cover a number of key aspects. These will include:

- * the suitability and comprehensiveness of the message list;
- * the performance of the system in terms of response times and message reception accuracies;
- * the utility of the RDS-derived data in assisting drivers to avoid congestion;
- * the ability of the RDS service to improve operation of the onboard navigation system, both in the manual and automatic data entry modes; and
- * the benefits obtained through additional applications of the RDS service.

The proposed time frame for RDS in Arizona calls for development, implementation, commissioning and initial operation to be achieved between the spring of 1991 and the summer of 1992. RDS messages would be used with manual updating of traffic events from the start of 1992. At the same time, work would be undertaken on the development of an interface between the RDS broadcaster terminal and the freeway control center computers, with automatic updating beginning in summer, 1992.

Project #4 - Highway AVI markers

This MIDAS project would involve the use of existing AVI technology to mark sections of Arizona highway, initially for HPMS section identification purposes. The project will use conventional passive AVI technology, though in this case the transponders will be installed either in the pavement or at the roadside, rather than on the vehicle. Each transponder will contain a unique, coded identification number. The reader equipment will be fitted on ADOT vehicles, and will interrogate the tags on each pass. After preliminary testing, this equipment configuration is expected to have two principal application areas in Arizona: highway maintenance, and vehicle navigation.

In the area of highway maintenance, the system will be used to automate the collection of pavement condition data. The reader equipment will be installed initially on ADOT vehicles that are used to measure parameters such as pavement roughness, profile and stiffness. Each time the vehicle passes a tagged highway location, the event will be recorded in conjunction with the pavement data. This will then provide a more complete and accurate record on which to base highway maintenance and construction activities. Evaluation of the approach by ADOT will focus upon improvements in these activities achieved through use of the system, as well as on technical performance of the markers and their readers.

The highway marker infrastructure will also provide a reference system in support of the previously implemented onboard navigation system. Detection of the uniquely encoded transponders will enable the system's onboard computer to establish its exact location in the network. This information will then be used to correct any dead-reckoning location errors that have accumulated during travel. The project will therefore examine the extent to which the onboard navigation system is improved as a result of this error correction reference system.

The installation of transponders in the pavement or at the roadside is proposed to commence in Arizona in the spring of 1991. This will continue until mid-1992, during which time the use of the marker system in support of maintenance activities will be investigated. From mid-1992, the transponders will also be used to provide reference markers for the onboard navigation system. It is expected that this development will occur at around the same time as ADOT's automatic traffic status updating using RDS, as shown in Figure 9.1.

Project #5 - Two-way, high-speed beacon demonstration

Project #5 of the MIDAS initiative will involve the demonstration and application of a roadside beacon system, similar to the RACS device already developed in Japan. The project will build heavily on work currently being undertaken in the HELP program covering the development of a two-way, high-speed AVI beacon system. The beacon system will permit large volumes of traffic and navigation data to be passed in both directions between the roadside and the vehicle, as vehicles pass reader sites at full highway speeds.

The principal application of the beacon system in the short-term will be in monitoring vehicle journey times and updating in-vehicle network databases.

Vehicles previously equipped with the onboard navigation system in Project #2 of MIDAS will also be fitted with two-way AVI transponders. The roadside beacons will be installed at strategic locations on the surface street networks of the navigation system test areas. Since the AVI transponders will contain unique identification numbers, it will be possible to calculate the journey time between specific beacon sites for each equipped vehicle. This information will then be used to update a database of average journey speeds on different links in the network. The database will be held in a central computer, to which each beacon will be connected via a communications link.

As vehicles pass the beacon sites, changes in the impedance of links in the network will be transmitted from the roadside to the onboard equipment. This will then permit the in-vehicle navigation computer to reassess its preferred route in the light of the beacon data. An interface will be developed between the AVI transponder and the navigation computer to facilitate this. The navigation system will then be operating in a more traffic-responsive mode, and will therefore be less vulnerable to nonrecurrent congestion.

The journey time data collected using the two-way beacon system will also support other traffic management approaches, in addition to the onboard navigation equipment. The system can be used to provide a further source of data in freeway and traffic control centers, complementing existing inductive loop and video monitoring. Drivers can be advised of congestion or incidents revealed by the beacon-derived data using roadside variable message signs. Information on journey times will also be transmitted using the RDS broadcasting service, for display in vehicles that do not possess the navigation system.

Evaluation of the beacon will focus primarily on its role in support of the route guidance system. The following factors will be of interest in this area:

- * how quickly and accurately can congestion and incidents be detected using the beacon approach?
- * what density of beacons and market penetration of transponders are required to successfully operate the system?
- * what accuracy does the equipment achieve in terms of data transmission and error correction?
- * to what extent does the provision of the beacon data improve the performance of the navigation system? and
- * is any additional benefit over an RDS-supported navigation system sufficient to justify the significant cost of the beacon infrastructure?

The period proposed for implementation of the beacon system in Arizona runs from the start of 1992 to the end of that year. This will include the installation of readers and onboard equipment, the establishment of the control center, and the interface with the navigation equipment. From the start of 1993, the beacon system will be used in conjunction with the onboard navigation device to operate a full externally-linked route guidance system, based on North American HELP microwave two-way high-speed AVI technology.

Project #6 - Advanced chip devices

This MIDAS project will involve the development and evaluation of advanced chip devices for automatic vehicle control applications. The conceived design of this technology is a pavement-embedded passive transponder that will be installed at intervals along the highway. The chips will be placed in cores drilled in the pavement, permanently attached flush with the pavement surface. While the devices are being installed, each chip will be individually programmed with its precise location in the road. The chips may also be programmed to include the heading and distance to the next in-pavement transponder, the maximum permitted vehicle speed, the minimum permitted vehicle headway and other special information that may be required.

The principal application of the advanced chip devices will be in supporting automatic longitudinal and lateral control projects, proposed for inclusion within Phase Two of Arizona's MIDAS study. A second major element of Project #6 will therefore involve research and development of the vehicle-mounted location transponder reader. This device will be capable of sensing the passive in-pavement chip, powering it fully using the radiated signal, reading the returned transponder code, and precisely locating its position for guidance purposes.

Prototypes of the chip and onboard reader devices will be developed and tested in laboratory and test track situations. Tests will focus on a number of aspects of system performance, including:

- * the ability of the reader to detect the presence of the chip and establish its exact location beneath the vehicle;
- * the read accuracy and error correction capabilities of the equipment;
- * the performance of the system at high vehicle speeds; and
- * the vulnerability of the system to water, snow or other obscurations on the pavement surface.

The development of the advanced chip devices in Arizona will start at the beginning of 1992 and will continue for two years. Up to mid-1993, this will be substantially a fundamental research project aiming to produce the basic components of the system exhibiting the desired characteristics.

At that time, Phase Two research will begin seeking to apply the chips to partially-automated default safety steering. The last six months of Project #6 will therefore be carried out in parallel with this element of the Phase Two MIDAS work. This will enable the two studies to feed into one another, such that the chip and reader design can be modified into a final form by the end of 1993.

Project #7 - Vehicle-to-vehicle communications

Like the previous MIDAS project, Project #7 of Arizona's program will be undertaken with the goal of developing technologies for application in the second phase of MIDAS. The project will involve the development of a high-speed, two-

way communications system capable of passing information between vehicles as they travel at full highway speeds. Again, the work will build substantially on experience gained in the area of two-way communications equipment in the HELP program. In this case, however, the dynamic nature of both communications components will add further complexity to the work.

The system will be designed to permit the transmission of a range of data between vehicles. This will potentially include the following:

- * vehicle speed, direction and location data;
- * warnings of vehicle maneuvers such as turns, braking, etc.; and
- * emergency status warnings.

The main components of the system will be an in-vehicle data processing and control unit and a transmitter/receiver unit. Prototypes of the vehicle-to-vehicle communications system will be tested in the laboratory and on test tracks. Evaluation will focus on the following:

- * the performance of the equipment in terms of read accuracy and error correction;
- * the ability of the system to operate satisfactorily over different distances;
- * the system's utility in providing greater than adjacent vehicle communication using a cellular communications approach;
- * the effects on system performance of rain, snow or electrical interference;
- * the system's ability to work at high vehicle speeds; and
- * the potential of the equipment to transmit large data volumes reliably.

The proposed timeframe for this study runs from mid-1992 through to the end of 1993. The first 12 months of this period will involve fundamental research aiming to advance the system to a state where it can be realistically applied and evaluated. The last six months of the study will then involve a large amount of track testing. The results of this testing will be used to finalize the design of the vehicle-to-vehicle communications system.

9.5 Phase Two projects and activities

The projects and activities outlined for the second phase of Arizona's MIDAS program will build upon and extend the Phase One work. Phase Two covers a period of four-and-a-half years, running from mid-1993 until the end of 1997. The main emphasis of the phase will be in providing driver support and default safety systems in relation to certain elements of the driving task. Overall

responsibility for vehicle control will be retained by the driver throughout this phase. Figure 9.2 presents the structure of the Phase Two effort, while details of the component projects and activities are summarized below.

Project #8 - Develop safety steering

The first project of the MIDAS Phase Two effort will develop and evaluate a safety steering system in Arizona. This will be based around the advanced chip devices and onboard reader equipment, developed in the previous phase of MIDAS. The system will be used to return the car to the center of the lane if the vehicle is drifting away and does not appear to be under positive manual control. When the steering is firmly operated by the driver, however, the automated element will not be activated. The system will therefore essentially operate as a backup device, maintaining lane discipline when the driver loses concentration or lets go of the steering wheel. It will also serve to assist vehicle control during strong crosswind gusts, tire blowouts and other, potentially life-threatening situations.

In order to produce such a safety steering system, it will be necessary to develop a number of basic components. First, the advanced chip devices and reader equipment will need to be optimized for the automated steering application. Second, a control algorithm and processor must be developed that can analyze signals from the onboard transponder reader and from the steering control system. This will use expert systems logic to decide whether the vehicle is satisfactorily under positive manual control, or if it has drifted away from the center of the lane due to inattentive driving or external influences. Finally, a connection to the steering system must automatically tend to correct the vehicle's position when the processor decides this action is required.

The system components and overall design will be tested in laboratory and test track conditions. Evaluations will examine the following aspects of system performance:

- * the system's ability to accurately locate and decode the in-pavement chips;
- * the reliability of the system in correcting the position of a drifting vehicle;
- * the extent to which the system may wrongly attempt to correct an intended deviation from the center of the lane;
- * the effects of vehicle speed and highway geometry on performance;
- * the effects of rain, snow or other obscurations on the pavement surface; and
- * reaction time and time required to correct vehicle position.

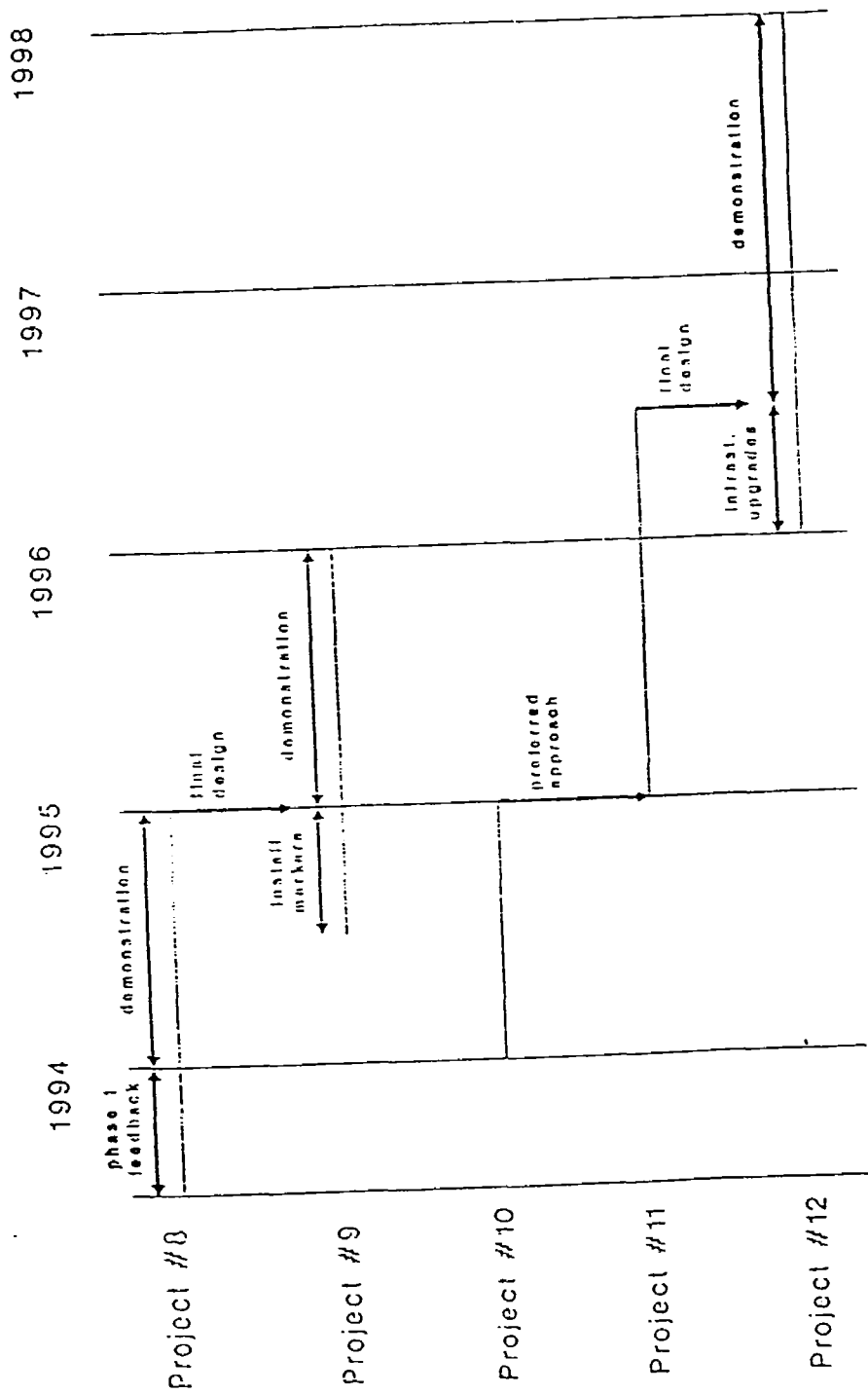

Figure 9.2 Phase Two schedule

The scheduled time frame for this project is from mid-1993 until the end of 1994. As outlined previously, the first six months of this study will run in parallel with the final six months of Project #6 of MIDAS. This will enable experience gained in applying the advanced chip devices to vehicle control to be fed back into their development, and vice versa. From the start of 1994, work will continue on the development of the steering control linkage and the control processor. The study will aim to conclude with an Arizona motor industry test track demonstration of the safety steering system toward the end of 1994.

Project #9 - Safety steering highway demonstration

This project will involve an operational highway demonstration of the safety steering system developed in Project #8 of the MIDAS effort. Advanced chip devices will be installed in a rural section of Interstate 40 near Yucca, Arizona, and in an urban section of freeway in Phoenix, for the purposes of implementing the demonstration. A number of test vehicles provided by motor industry partners will be equipped with the necessary in-vehicle sensing, processing and steering control devices. These will then be operated on the instrumented highway sections, initially separated from and subsequently integrated with the general highway traffic.

The demonstration will enable the performance of the system to be evaluated in an actual highway environment. It is also expected to provide an eloquent indication of the successes of the MIDAS program to the transportation industry and to the Arizona public, as a major international IVHS "first."

The project will run from mid-1994 through to the end of 1995. During the first six months of this period, the advanced chip infrastructure will be installed on the Arizona freeway test sections. By running this process in parallel with the final six months of the development project, it is anticipated that the system will be sufficiently advanced to permit the freeway installation to proceed. Following completion of the development project at the end of 1994, a 12-month highway demonstration and evaluation of the safety steering system will run throughout 1995.

Project #10 - Longitudinal control systems basic research

Project #10 of the MIDAS program will involve research and development of systems designed for the longitudinal control of vehicles traveling at full highway speeds. Approaches that will be investigated in the study include the following:

- * vehicle following systems based on forward-looking radar, sonar, infrared and video image processing technology;
- * intelligent cruise control systems based on in-pavement markers or roadside beacons; and
- * longitudinal control systems based on high-speed two-way vehicle-to-vehicle communications approaches.

The first part of the study will focus on a review of previous experience in longitudinal vehicle control. This will seek to establish the characteristics, merits and disadvantages of the alternative approaches. Evaluation of technical approaches to longitudinal control will include consideration of the following factors:

- * the ability of the systems to maximize efficiency in terms of the throughput capacity of highway lanes;
- * overall levels of comfort and convenience for drivers and passengers under automatic longitudinal control;
- * the safety and reliability of the approaches, based on the performance of the data communications system and control algorithm;
- * the ability of the systems to stop vehicles safely and quickly in the event of an emergency;
- * the suitability of the systems for use in hazardous weather situations caused by snow, ice, rain, etc., as encountered in Northern Arizona, as well as sand and dust storms in desert regions; and
- * the adaptability of the systems for use on a range of vehicles with different operating characteristics.

The study will also involve test track examinations of longitudinal control systems that are commercially-available or have been developed to the status of operational prototypes. Current research activities in this area suggest that a number of alternative technical approaches will be available for evaluation by the time this study commences. Track testing in Arizona will then provide valuable operating experience as a further input to the comparison of technical approaches.

The comparative evaluation of longitudinal control systems will be undertaken with the principal objective of identifying a preferred approach or combination of approaches to support future automation concepts. The results of the study will then be fed into subsequent projects of Arizona's MIDAS program. This will enable the performance of the recommended equipment configuration to be evaluated in its intended area of application.

The proposed time frame for the evaluation of longitudinal control approaches is from the beginning of 1994 to the end of that year. The review of alternative approaches will be undertaken at the start of this period, while available systems will be evaluated on the test track toward the end of the year.

Project #11 - Develop safety driver

This project will utilize the results of previous MIDAS studies in Arizona to develop a safety driver system. The safety driver system will be based on the advanced chip devices and preferred longitudinal control approach to introduce elements of safety default vehicle speed and headway control. The system will

be used to automatically accelerate or decelerate the vehicle according to highway geometry and traffic conditions. Manual control will be retained at all times, with automatic intervention limited to safety defaults of speed and steering.

The development of the safety driver system will require comprehensive investigation and integration of several component technologies. The in-vehicle transponder locator device must be optimized to suit the longitudinal control application. Additional devices required to support the system, such as radar or video image processing technologies, must be developed to a sufficient state of advancement. Advanced signal processor and control algorithms will also be required, capable of analyzing signals from various sensors and taking action when required.

Following development of the various vehicle components in laboratory conditions, the finally integrated system will be installed in motor industry partner vehicles for test track evaluation. The control unit will be linked to the vehicle's fuel supply and braking system for automatic speed and headway adjustment. Equipment will also be installed in the test track surface, as required by the preferred equipment configuration. Evaluation of the safety driver system will then focus on the following:

- * the reliability of the system in performing default, safety deceleration and steering when required;
- * the acceptability of the system to drivers;
- * the extent to which automatic longitudinal control unnecessarily affects manual control;
- * human factors considerations concerning possible overreliance of the system on the part of the driver; and
- * the potential of the system to improve highway capacity and safety.

The safety driver development project will commence at the start of 1995, running through to mid-1996. Initial effort will be focused on developing and integrating the individual system concepts. Later work will then involve test track evaluations of the integrated safety driver systems. A preferred system design will be produced at the end of the study.

Project #12 - Demonstrate safety driver

This project will involve a highway demonstration of the safety driver system developed in Project #11 of MIDAS. The system will be demonstrated on the same rural and urban freeway system sections previously used to exhibit safety steering. By building on the successes of the safety steering project, the safety driver demonstration will provide a further indication of Arizona's achievements in the area of vehicle and highway automation. The project will also enable the preferred design of the safety driver system to be evaluated in an actual highway environment.

The proposed time frame for this project runs from mid-1996 to the end of 1997. During the first six months of the study, the freeway sections previously instrumented for the safety steering device will be upgraded to support the safety driver system. This will potentially require the installation of additional or modified advanced chip devices. It may also be necessary to install further roadside equipment in support of other longitudinal control elements of the safety driver system. The system will then be installed in test vehicles and demonstrated on the highway over a 12-month period in 1997.

9.6 Phase Three projects and activities

Building on the results of Phase One of MIDAS, Phase Two research activities in Arizona will develop a number of projects and activities that automate certain elements of vehicle control. These will be used primarily for backup purposes, becoming active only when a lack of positive manual control is detected. Phase Three of MIDAS will further enhance and develop these technologies, resulting in a much greater degree of automated vehicle control. Rather than acting as a backup, therefore, systems will be used to replace the role of the driver in performing some of the control tasks.

The MIDAS Phase Three work will inevitably be dictated to a significant extent by the findings of earlier phases. The longer-term nature of Phase Three, and the uncertainties associated with the results of Phases One and Two, make it unrealistic to accurately predict when specific projects and activities will occur. Therefore, only approximate time frames have been included within the project descriptions. Further details of the activities proposed for inclusion in Phase Three of Arizona's study are presented in the following paragraphs.

Project #13a - Develop automatic steering

This project will build on earlier MIDAS work to develop a full automatic steering system. The system will be designed to provide lateral vehicle control on suitably equipped highway sections, removing this task from the driver. On automated sections the driver will not need to keep his hands on the wheel, and will not be permitted to steer the vehicle under normal circumstances. The only exception to this will be when a fault in the automatic steering system is detected. If this occurs, the driver will be alerted and the vehicle will revert to manual control. The occurrence of this event will also be transmitted to nearby vehicles using the vehicle-to-vehicle communications system developed previously in MIDAS.

The automatic steering system will be significantly based upon the earlier safety steer system. However, some modifications will be needed to implement continuous automatic control. In particular, changes in the control algorithms and levels of security default will be required to reflect its change of status from a backup device to a full-time vehicle operator. Further research will also examine fault detection and the ways in which control can be passed back to the driver in the event of system failure.

The development of the automatic steering system will involve a series of laboratory and track tests. Test track evaluations on the final system design will be used to establish whether the equipment is suitable for full operation on the highway. The project will take place around the 1998-1999 time period.

Project #13b - Develop automatic driver

While the previously described project will develop a fully automatic steering system, Project #13b of the MIDAS initiative will aim to produce an automated longitudinal control system. The automatic driver system will have full control over a vehicle's acceleration and braking on suitably equipped sections of the highway. The system will therefore be responsible for adjusting the vehicle's speed in accordance with highway geometry, traffic conditions and potential obstacles. Again, the driver will not be required to control the vehicle on equipped sections except during failure of the automated system.

The automatic driver system will be developed around the earlier safety driver system. The project will involve enhancement of the safety driver device to provide continuous automatic longitudinal control. The system's control algorithm will therefore need to be modified to support this development. Fault detection and methods for transitioning between automatic to manual control will also need to be considered in the study.

Following a period of research and development, the safety driver system will be demonstrated in a test track environment in Arizona. This will provide the opportunity to establish the feasibility of using the system on the highway, and will also assist in finalizing the system design. The project will run in parallel with the automatic steering study in the 1998-1999 time period.

Project #13c - Develop advanced vehicle command and control system

This project will draw together the results of all work previously undertaken in MIDAS to develop a full AVCCS. The system will be used to operate full longitudinal and lateral control on suitably equipped highway sections. In addition, the system will provide in-vehicle navigation and information facilities on all areas of the highway network.

The principal focus of the study will be the integration of the various component technologies developed earlier in MIDAS to produce a coordinated AVCCS. Work will also be undertaken into the combination of the components' control processors into a single AVCCS control unit. In addition, further research will be required to introduce to the AVCCS features such as the ability to merge and exit the vehicle into and from the automated lanes.

Research into the AVCCS will be undertaken in parallel with the development of the automatic steering and driver systems. This will permit the various components to be integrated into a coordinated system. Fully operational demonstration and evaluation of the AVCCS will then be undertaken following completion of the automatic steering and driver systems development projects.

The AVCCS will be demonstrated in a test track environment, before its implementation in the highway in the final MIDAS activity.

Project #14 - Full AVCCS highway demonstration

This project will be the last of Arizona's MIDAS initiative in its currently proposed structure. The project will involve the highway demonstration of the AVCCS developed in the previous study. The AVCCS will be installed and operated on the Arizona freeway system over a suitable demonstration period. This will permit the system to be fully evaluated, effectively providing an overall evaluation of the MIDAS program. The demonstration will also establish the feasibility of full-scale implementation of AVCCS, and will identify any additional research and development requirements to achieve this. The AVCCS demonstration will occur around the year 2000, following a successful conclusion to the test track system evaluations.

9.7 Technology assessment

This section of the chapter seeks to summarize the benefits which will accrue from the various technologies proposed for investigation in Arizona's MIDAS initiative. In addition to relieving urban traffic congestion, many of the systems will also give significant benefits in areas such as accident reduction, fuel saving or driver comfort and convenience. The following areas have therefore been included in the assessment:

- * capacity gains;
- * vehicle travel times;
- * vehicle mileage traveled;
- * air quality;
- * noise pollution;
- * traffic safety;
- * driver comfort and convenience; and
- * provision of additional traffic data.

As outlined in previous sections, MIDAS has been developed as a coordinated series of projects and activities leading toward fully integrated AVCCS. However, each of the component technologies will be implemented independently before AVCCS is developed as an integrated system. Even before they are used within the context of AVCCS, each of these technologies has potential to bring major benefits. The main component technologies that will be investigated in MIDAS are as follows:

- * autonomous onboard navigation;
- * RDS traffic information broadcasting;
- * externally-linked route guidance;
- * variable speed control;
- * collision avoidance;
- * automated headway control;
- * automated steering control; and
- * full highway automation.

Autonomous onboard navigation systems

Autonomous onboard navigation systems can assist drivers in both route-planning and route-following tasks under essentially steady-state conditions. They can take account only of average traffic and are unable to cope with dynamic real-time variations in traffic conditions. In order to provide the maximum benefits, the map databases on which these systems work need to reflect network characteristics such as travel cost by time of day, as well as distance.

One of the major benefits of onboard navigation equipment will come from reductions in vehicle travel times and mileage. These result from the system's ability to direct drivers along optimal routes, thereby reducing navigational wastage. The main benefits due to this reduced navigational wastage will accrue to the individual drivers who have bought and utilized the system. However, there will also be secondary benefits to all traffic, due to the reduction in congestion caused by the elimination of some excess travel incurred by fitted vehicles.

Additional benefits will arise in the area of driver comfort and convenience. These result from the ability of onboard navigation systems to provide drivers with routing advice which can help reduce uncertainty. This is particularly true at unfamiliar intersections where specific guidance will reduce or eliminate driver hesitation. Secondary benefits in terms of improved road safety may also be possible when driver uncertainty is reduced. Finally, to the extent that travel times and VMT are cut there may be reductions in fuel consumption, improvements in air quality and reduced noise pollution. These, however, would be small and are difficult to quantify.

A study of the extent of navigational excess travel in the U.S. was completed in 1986 by KLD Associates for the FHWA [1]. This study estimated the proportion of all travel that is unnecessary under steady state conditions, as follows:

Proportion excess distance	=	6.4 percent
Proportion excess time	=	12.0 percent

In reality, a self-contained guidance system would be unlikely to recover all of the excess time, due to difficulties in establishing minimum time routes and other system imperfections. In order to take account of this, a factor of 80 percent efficiency is estimated for time savings, giving a figure of 9.6 percent for the maximum proportion of total travel time that could reasonably be reclaimed under steady state conditions.

Having established the proportion of total journey time or distance that could be saved, an assumption must be made concerning the criterion drivers would use to optimize their travel. This is necessary because in many cases the minimum distance route between two points does not coincide with the minimum time route. Drivers will therefore, on average, choose a route which represents some trade-off between time and distance, saving a proportion of excess time and a proportion of excess distance.

Experience in both the Japanese CACS project and European investigations into route guidance suggests that most people would normally utilize something approaching a minimum time criterion for route selection. The estimates developed for this analysis are therefore that, typically, a driver will save 75 percent of the attainable journey time saving and 25 percent of the attainable journey distance saving. Overall, therefore, a system user will save approximately 7.2 percent on journey time and 1.6 percent on journey distance during travel under steady state conditions.

RDS traffic information broadcasting

In assessing the RDS traffic information broadcasting system, two immediate areas have been identified in which major benefits would be achieved. The first of these is reduced travel times for motorists. RDS will allow drivers to be better informed in the event of an incident. Motorists receiving these warnings will have the opportunity to divert to avoid the incident and will thereby reduce congestion build up at the scene of the incident. Reducing congestion in this way may help to minimize lost time to both vehicles equipped and those not equipped with RDS receivers.

Second, there may be improvements in comfort and convenience to drivers utilizing RDS. These would result from the fact that the in-vehicle RDS receiver is a highly selective device. Only information which is pertinent to a driver's route or corridor will be provided by the system. This allows the driver to rely on receiving only relevant traffic messages. Additionally, RDS is capable of operating in conjunction with normal car radio and audio cassette equipment, muting the radio program or tape when a message is broadcast. This avoids the need for the driver to constantly retune the radio to ensure message reception.

A third important area of potential benefit from RDS messages will relate to weather conditions, or warnings of traffic accidents ahead. Where drivers are unable to divert, or reschedule their trips, they will arrive at incidents better informed, and therefore better able to avoid being surprised. Although the road safety benefits of these advance warnings are difficult to quantify in purely financial terms, there is excellent reason to suggest that gains could be very worthwhile.

Detailed appraisals of RDS traffic broadcasting have been carried out by CRC and others in studies for NCHRP, DRIVE, the Dutch Ministry of Public Works (Rijkswaterstaat), and the UK Department of Transport. These indicate that around 98 percent of the costs of a fully implemented digital traffic broadcasting system would be borne by vehicle owners, with less than 2 percent of the costs accruing to public agencies. Attractive rates of return are projected in terms of delay reductions alone. The potential benefit-cost ratio to highway agencies is particularly promising, since most of the costs are met directly by users. It is for these reasons that RDS has been given a particularly high priority within Arizona's MIDAS program proposal.

Externally-linked route guidance

The third technology evaluated in this analysis is externally-linked route guidance. The most advanced point of MIDAS in this area is a system with a two-way communications link between in-vehicle equipment and a roadside beacon infrastructure. This type of system would potentially provide the highest level of benefits, providing dynamic routing information which is fully responsive to network conditions. This type of system is exemplified by the ALI-SCOUT system currently undergoing major trials in Berlin, the AUTOGUIDE system being implemented in London, and the Japanese route guidance systems which are being developed in the RACS project.

An externally-linked route guidance system would help eliminate inefficient route choice to the greatest degree possible. It would not only reduce excess travel under steady state conditions, but would also reduce suboptimal route choice which occurs due to real-time changes in traffic, highway or environmental conditions. The degree of responsiveness to these changes in network conditions would be the highest possible, with the system reacting to incremental changes in conditions as well as the occurrence of major incidents.

The system would, therefore, aid in reducing both recurring congestion and spontaneous congestion caused by incidents, by re-routing a proportion of the traffic away from congested areas. This would benefit both individual vehicles fitted with appropriate guidance equipment, and all other traffic, which would experience reduced congestion caused by the re-routing of equipped vehicles.

Additional benefits would also accrue in other areas. For example, implementation of an externally-linked route guidance system would provide a very good source of traffic data for evaluation and optimization of advanced traffic management systems. The vehicle-to-roadside communications link will allow information on traffic flows, journey times, and trip origins and destinations to be determined. This will be very valuable for transportation planning and traffic monitoring over extended periods.

Drivers whose vehicles are fitted with appropriate in-vehicle units to receive real-time route guidance information would receive the greatest benefits from a route guidance system. These benefits would take the form of reductions in excess miles traveled and journey times. The first stage in evaluating these user benefits involves quantifying the extent of the problem of excess travel in terms of a proportion of total vehicle travel. For evaluating the benefits of

route guidance under essentially steady-state conditions, it is assumed that the maximum recoverable waste is the same as for an onboard navigation system: 6.4 percent of total distance traveled and 9.6 percent of total journey time.

However, it is emphasized that these estimates are restricted to trip planning and route following under steady-state conditions. The excess travel time caused by deficiencies in route choice due to real-time dynamic variation in network conditions is not included. In order to assess this additional benefit, the results of major trials conducted in Japan have been examined [52, 53]. These involved comparisons of journey times between test vehicles equipped to receive dynamic route guidance information, and non-equipped vehicles. The trial results showed that the attainable time savings utilizing real-time route guidance information in dynamic traffic conditions ranged from 9 percent through 15 percent with a mean time saving of 11.5 percent. This average figure suggests that provision of real-time route guidance in dynamic traffic conditions should have a significant additional impact over and above the time saving achievable through static route guidance information in steady-state conditions.

The reduction in vehicle miles traveled will lead directly to a similar benefit in terms of fuel savings. Also, where travel time and VMT are reduced due to traffic redistribution, further benefits may accrue through improved air quality and reduced noise pollution. Reduction in VMT and the ability of the system to provide timely and accurate hazard warning information to drivers will also lead to a probable benefit in terms of net accident savings.

Variable speed control

One of the applications of the longitudinal vehicle control approaches proposed for investigation in MIDAS is VSC, which would allow vehicle speeds to be automatically optimized. The main potential benefits of these systems are increased safety and improved fuel efficiency, particularly at approaches to traffic signals. Overall, vehicle speeds might be optimized to prevent collisions, maximize throughput and minimize stops. Additionally, removing the task of controlling speeds from the driver will have some comfort and convenience benefit.

To allow variable speed control systems to become a practical reality with widespread implementation, a low-cost infrastructure will be needed which could reasonably be installed on most roads. The option of small permanent reference markers at differential spacings in the traffic lane, outlined in the project descriptions, could meet the low-cost infrastructure requirements and be deployed almost everywhere.

The safety benefits of a system which automatically slowed up traffic approaching reduced speed zones or adverse highway geometry could be substantial. Like current cruise controls, intelligent cruise would not force drivers to comply with limits, but it would help them to do so by making compliance easy. The safety gains and comfort and convenience advantages could well be sufficient to promote widespread acceptance of the system.

A subsequent enhancement to the system could transmit variable speed guidance using AVI beacon technology, for example approaching intersections. Fuel savings and improved throughput achieved by such a system at traffic signals would be similar to those of the German advanced traffic control "funnel." This system helps drivers select the optimum speed for approaching signals. Significant benefits have been claimed for the funnel technique, which is implemented using variable message signs. An automated system based on variable speed control might do significantly better than the variable message signs at funneling traffic into signalized intersections.

A further potential use of variable speed control technology would be on freeways to meter traffic into congested freeway sections and prevent breakdown of flow. This would be analogous to ramp metering, except that speeds would be automatically controlled on the mainline through VSC technology. Phoenix will provide an ideal test bed for further evaluation and demonstration of these rapidly developing technologies.

Collision avoidance

The longitudinal control technologies investigated in MIDAS Phase Two will also have the potential to introduce collision avoidance and automatic emergency braking to suitably equipped vehicles. The obvious benefit of collision avoidance will be in reducing accidents. In particular, systems could help eliminate a significant proportion of rear-end accidents, together with a smaller proportion of head-on accidents. These accounted for 24 percent of all road traffic accidents in 1985. Fixed object and intersection collisions are also possible candidates for effective system use.

An associated secondary benefit would be that of reduced congestion occurring at the scene of traffic accidents. The system may also lead to unquantifiable benefits in terms of driver comfort through increased confidence in having the collision avoidance system. Similar benefits in terms of driver confidence and comfort are currently promoting the penetration of antilock braking systems deeply into the new vehicle fleet.

Automatic headway control

AHC will provide benefits through relieving the driver of the car-following task and maintaining constant headways between vehicles. This could bring benefits in reduction of accidents, reduction in fuel consumption, and reduced congestion through the utilization of increased highway capacity. Accident savings would result in a similar way to those achieved through collision avoidance. Improved driver comfort and convenience could also accrue from the system's additional capabilities over conventional cruise control.

AHC has the potential to reduce headways and optimize vehicle speeds, thereby cutting congestion, travel times, operating costs and pollution. An AHC system's ability to increase highway capacity will depend on the headway it allows between vehicles. A system which allows for "brick wall" stopping--in which it is assumed that a lead vehicle may stop as if it has hit a brick wall--is safer, but

much less effective in providing throughput than a system which follows less severe stopping criteria. Indeed, such a system could even result in lower highway capacities than those currently experienced.

Opinions vary on the question of a set of criteria for AHC close-following distances. The brick wall stop criterion is certainly not met on existing highways under manual control. It may also be unnecessarily severe in an automated highway situation, where catastrophic accidents will hopefully become extremely infrequent occurrences. If AHC is first implemented in mixed traffic, however, in order to achieve incremental acceptance, then rapid stopping capabilities may need to be retained. Product liability concerns also tend to mitigate against the reduced headways needed for capacity increases. These are in-depth issues for appraisal within the early stages of the MIDAS program.

Automatic steering control

ASC is technically a near-term possibility. It therefore receives a high priority within Phase Two of Arizona's MIDAS program. The differential-spacing marker system proposed for variable speed control could also provide affordable automatic steering for use as a driver support system on a wide range of road types. Like intelligent cruise, first generation systems would assist the driver's lane-following task without removing his ultimate responsibility for vehicle control.

Once default safety steering became accepted and deployed, a second phase would be to establish exclusive ASC lanes. The main potential benefit of automatic steering control for relieving traffic congestion lies in utilization of narrow lanes. The tight limitations imposed on a vehicle's lateral position by automatic steering control would potentially allow utilization of traffic lanes much narrower than normal. This could allow an increase in capacity to be obtained without the need for new construction. Other major benefit areas include reduction of accidents, and increased driver comfort and convenience.

The full capacity benefits of utilizing automatic steering control in narrow traffic lanes would accrue in certain specialized highway situations such as construction zones and congested urban freeway sections. The narrow lanes would be restricted to suitably-equipped vehicle usage, and would need to be segregated from each other without the use of barriers. Under these circumstances, the benefits of automated steering in increasing traffic throughput within existing rights-of-way could be very substantial.

Full highway automation

The eventual implementation of full highway automation could potentially have far-reaching consequences in the relief of congestion, as well as in areas such as safety, time-savings, comfort and convenience, and operating cost reductions. The main benefit for congestion relief would lie in increasing highway capacity above the normal levels attainable on conventional highways. The extent to which this will be possible depends on the nature of the system deployed. Land take requirements could be less than those for conventional highway construction

through the use of automated steering systems. Additionally, an automated highway would provide large volumes of real-time traffic monitoring and control data which could be used for a variety of system optimization purposes.

Journey time savings would result from scenarios where capacity flow levels were achieved with speeds maintained at 55 mph, compared to a conventional highway which would typically operate at capacity around 30-35 mph. Highway automation incorporating automatic headway control and variable speed control elements would also allow for substantially reduced fuel usage. Accident reductions on an automated facility could be expected through elimination of many accidents due to driver error. It is for these various reasons that highway automation will be a major focus of the MIDAS program, offering substantial benefits that make it a major, long-term goal for Arizona's IVHS initiative.

9.8 Funding requirements

This section outlines funding estimates developed for the proposed MIDAS program in the State of Arizona. This includes estimates of resource levels required for projects and activities within the three phases of the program. For the first phase, cost estimates have been developed for individual projects, broken down into various cost headings. Phase Two costs are broken down according to the constituent activities, while Phase Three has been allocated a single cost estimate, reflecting the longer-term nature of the work and the substantial degree of interaction between the activities.

In addition to providing cost estimates for the MIDAS phases and activities, costs of overall program management have been considered for the State of Arizona. These will be necessary to select and administer contracts, to review progress, and to ensure satisfactory coordination between the many program activities. Finally, potential sources for funding MIDAS are also discussed in this section.

Phase One costs

The near-term nature of Phase One projects and activities of Arizona's MIDAS program makes it possible to break down cost estimates into various headings. These reflect the major items of work that will need to be undertaken in each study. Costs for each of the Phase One projects are presented below.

Project #1: Management development study	
Initial feasibility study	\$ 30,000
Concept development study	\$ 30,000
Multi-state program launch	\$ 90,000
Total project cost	\$ 150,000
Project #2: Autonomous vehicle navigation	
Database coding	\$ 200,000
Equipment procurement/installation	\$ 80,000
Initial testing	\$ 70,000

	Operational evaluation	\$ 100,000
	Total project cost	\$ 450,000
Project #3:	Traffic information broadcasting	
	Message definition	\$ 50,000
	Location coding	\$ 150,000
	Broadcast message management software	\$ 75,000
	Broadcast hardware	\$ 50,000
	Develop in-vehicle terminals	\$ 250,000
	Initial testing	\$ 75,000
	Operational evaluation	\$ 100,000
	Total project cost	\$ 750,000
Project #4:	Highway AVI markers	
	Feasibility appraisal	\$ 75,000
	Initial testing	\$ 50,000
	Equipment procurement	\$ 125,000
	Detailed testing/development	\$ 100,000
	Navigation system interface	\$ 50,000
	Total project cost	\$ 400,000
Project #5:	Two-way, high-speed beacon demonstration	
	Design study	\$ 150,000
	Equipment procurement/installation	\$ 400,000
	Control center development	\$ 250,000
	Navigation system interface	\$ 200,000
	Initial testing	\$ 300,000
	Operational evaluation	\$ 200,000
	Total project cost	\$1,500,000
Project #6:	Advanced chip devices	
	Feasibility/design study	\$ 50,000
	Laboratory testing	\$ 100,000
	Prototype development/testing	\$ 250,000
	Final design/specification	\$ 25,000
	Total project cost	\$ 425,000
Project #7:	Vehicle-vehicle communications	
	Design study	\$ 125,000
	Develop prototypes	\$ 300,000
	Testing/appraisal	\$ 450,000
	Final system development	\$ 250,000
	Equipment procurement	\$ 300,000
	System evaluation	\$ 175,000
	Total project cost	\$1,600,000
	Total Phase One Cost	\$5,275,000

9.9 Summary

This chapter has presented a summary of the MIDAS IVHS program plan developed for the State of Arizona. It is envisioned that the broader ENTERPRISE initiative will ultimately consist of a number of state-level programs similar to MIDAS. However, the proposed ENTERPRISE participants are all at different stages of the IVHS program development process. The MIDAS program will therefore provide a useful model for review by other states in preparing plans for future IVHS research, development and operational evaluation activities. In particular, the MIDAS program identifies a number of issues that should be covered by the ENTERPRISE states in their IVHS program development actions. These can broadly be summarized as follows:

- * What is the overall structure of the IVHS program, in terms of its component projects and activities and the way in which these interrelate?
- * What is the timeframe for the overall program, and for each individual project?
- * What is to be achieved in each project or activity, and how is this to be undertaken?
- * What locations will be used to develop and evaluate IVHS technologies in the program?
- * What public and private sector organizations will be involved in the activities?
- * What technologies will be developed through the program, and what will be the benefits of their use?
- * What criteria and environments will be used to assess the performance of technologies developed in the program?
- * What will be the cost of the program, in terms of individual projects and activities and overall program management?
- * What sources of funding are available for the program?
- * What is the ultimate goal of the program, and the future direction after completion of the work?

activities, and will also likely result in correspondingly higher management costs. Program management during these phases is therefore estimated at \$1,000,000 per year.

Funding sources

The estimates outlined above clearly indicate that a significant level of funding will be required to perform the technical studies and support overall management of the MIDAS program. Similar funding levels may also be appropriate for other ENTERPRISE participants. However, there are a variety of sources through which the necessary funds can be obtained. One obvious source is state funds, providing a clear indication that the state is prepared to invest in its belief in the potential of IVHS.

Another potential supporter of the MIDAS initiative and the broader ENTERPRISE effort is the FHWA. The FHWA has recently provided \$5 million of federal assistance to ADOT for the Crescent Demonstration, as well as supporting several further projects being undertaken by potential members of ENTERPRISE. This confirms that the FHWA is willing and able to support IVHS initiatives that are well organized and have significant benefit potential. The FHWA may therefore be prepared to make a substantial contribution to state-level programs such as MIDAS, as well as the broader ENTERPRISE effort.

Much of the proposed IVHS research will potentially be undertaken by universities or other public research organizations. It may therefore be possible to fund a proportion of these efforts using research grants and other established funding channels.

The private sector is another important area of potential funding for IVHS activities. The private sector could assist states through both direct and indirect contributions. These could include free use of test tracks and research facilities, plus participation in working groups or planning sessions by industry personnel.

Some private sector organizations may be willing to make direct financial contributions to support IVHS activities. In particular, automobile manufacturers and electronics companies may partially fund projects aimed at developing systems within their areas of business. Funding of such activities could be similar to the mechanism used in the European DRIVE program. In DRIVE, private sector participants provide a 50 percent match to research funds from the government sponsor.

Finally, some IVHS projects and activities could effectively be funded by international collaborative efforts. This approach would utilize the results of overseas work, particularly European and Japanese research, avoiding duplicative efforts and providing resultant cost savings.

10. ORGANIZATIONAL STRUCTURE

10.1 Introduction

This chapter presents a proposed organizational structure for the ENTERPRISE initiative. Specifically, this structure will accommodate the activities to be performed within each participant's coordinated IVHS research, development and operational testing program. The chapter also includes an outline organizational structure for the GALACTIC bridging effort of the ENTERPRISE program.

A key characteristic of this organizational structure, and the element likely to present the greatest challenge, can be summarized by the word "partnership." ENTERPRISE will likely contain a cross-section of participants drawn from federal, provincial, state and local government, universities, and the private sector. This approach is wholly consistent with the recommendations of U.S. Secretary of Transportation, Samuel Skinner, in the recent National Transportation Policy and is already reflected in the organization of the U.S. national coordinating body, IVHS AMERICA.

This organizational partnership is an important goal of any new IVHS initiative, and is an aspect which must be addressed with care if an appropriate balance of views is to be maintained within the program management. While state government, for instance, may be seeking to achieve wide-area improvements in travel conditions, local authorities may bring a much narrower perspective and a focus on a very specific and localized problem. Similarly, university participants may wish to pursue long-term, fundamental research activities with uncertain outcomes, while the private sector, with an eye to the corporate "bottom-line", must look at short-term system deployments. The organizational structure must therefore be designed to avoid conflicts between these different biases and perspectives.

Beyond this introduction, the chapter describes the basic considerations to be taken into account in developing a program organization. The subsequent section recommends a broad organizational approach for state-level components of the ENTERPRISE initiative, before focusing on specific management activities to be included in the structure and a committee-based approach for achieving this. Options for the organization and funding of the GALACTIC bridging project of ENTERPRISE are also considered in the chapter.

10.2 Organizational considerations

A number of models for public-private partnerships already exist in the United States and can be reviewed for their applicability to an IVHS initiative. These include the Health Effects Institute, directed toward health and safety issues in the automotive industry; the Strategic Highway Research Program (SHRP), a 5-year, \$150 million research program examining technical issues relating to asphalt, concrete, highway operations, and long-term pavement performance; Sematech, a consortium addressing microchip technology development; and HELP, a

research and operational testing program developing a commercial vehicle monitoring and management system to benefit both government and the motor carrier industry.

While each of these represents a partnership of interests, it is important to note that there is little similarity in the organizational structures and a clearly inconsistent approach in federal participation. This may be due to an uncertainty at federal government level of how best to stimulate private sector interest in initiatives where this participation is either valuable or essential. To accommodate this need, many arrangements have been made which allow direct private sector commercial benefits through innovative funding mechanisms and by addressing critical basic issues such as anti-trust.

The current situation in the field of IVHS also has some important characteristics to guide future organizational developments. First, a substantial base of IVHS technology already exists and in some cases is being demonstrated and evaluated. Standardization is an important area where work is also either underway or is being defined. In addition, however, the full range of IVHS technologies display very large differences in their development timeframes. It should therefore be noted that public and private sector sponsors can lose interest in long-term projects which do not demonstrate interim benefits.

While there is a rapidly expanding base of groups and individuals interested in IVHS and a sense of time pressure due to foreign competition, there still exists some impediments to IVHS implementations through existing inertia or current institutional arrangements. Similarly, in some cases, the end user groups of IVHS are undefined. Involving users at an early stage may speed market development. Clearly there are major opportunities for increasing public awareness and therefore financial and political support for IVHS activities.

Reviewing these issues indicates that an IVHS program should emphasize deliverables that will demonstrate the potential of useful technologies. Getting those deliverables into use will rely on both available technology as well as new research. Any organizational structure must provide for successful systems development management as well as research support. A successful organizational arrangement should also overcome obstacles to early testing and demonstration of near-term technologies as well as providing a framework for longer-term research and a focal point for public support.

In turn this helps to define a series of core activities that must be provided by an IVHS organizational structure:

- * Planning and evaluation, including program definition, technical coordination and oversight, and development and implementation of technical evaluation procedures.
- * Standards and protocols, for example as related to radio frequencies, in-vehicle displays, and digital maps.
- * Legal issues, such as anti-trust, liability and licensing.

- * Outreach, including public information and education.
- * Program management, such as project definition, project prioritization, project solicitation and award, contract management, and financial administration.

In summary, the key considerations in developing an IVHS organizational structure can be defined as follows:

- * It should be sufficiently straightforward to allow program activities to begin quickly;
- * It should be sufficiently flexible to accommodate program expansion;
- * It should provide for early demonstrations and products;
- * It should provide for public-private cooperation; and
- * It should promote the program and IVHS in general.

10.3 Organizational options for state-level programs

A specific organizational approach is investigated in this section. This is directed toward the management of state-level programs in the ENTERPRISE initiative. The recommended organizational structure is based upon an approach identified in the MIDAS development study. However, the approach recommended for the State of Arizona should be broadly applicable to the other ENTERPRISE participants, with only minor modifications to reflect different needs and political structures.

The proposed structure places the focus of the internal program within the State Department of Transportation (DOT) or equivalent organization. The organization, however, will represent a broader public/private effort, and stresses the need for this IVHS initiative to be a cooperative partnership between all participants involved.

The DOT will serve as the focal point for the management and organization of the IVHS program, having primary responsibility for the highway system and transportation needs in the state. This structure will build upon the DOT's capabilities and expertise and apply them to developing IVHS solutions. There would still be a need for federal and local government together with private sector involvement in IVHS development. The state DOT would provide the leadership in bringing these parties together.

Each participating DOT or equivalent body should therefore begin immediately to take the necessary actions to accelerate the IVHS program activities through an appropriate organizational structure. As programs produce early results and demonstrate the value of IVHS technologies, this will increase the creditability of the technology. In parallel, state DOTs should begin to initiate the public

and private sector cooperation that will ensure the success of the program over the long term.

To accomplish these goals a streamlined organizational structure is proposed. Selected policy and executive groups will be charged with policy making, overall management and technical responsibilities, and will have strictly limited membership representation covering the key participating organizations in the various state-level IVHS programs.

At the highest level in the organization the policy board will be made up of senior management representatives of the key program participants. This group will be responsible for overall program direction and policy decisions. It will determine the broad direction of research, testing and implementation activities taking account of the priorities within the state. This policy committee will direct and be supported by other groups in the structure.

Membership of the policy board should be limited to one representative per organization, to accelerate the implementation of the state-level programs. Membership would comprise the DOT Director (or his representative); a city government representative; and key industrial participants. As programs expand so could membership of the policy committee, up to a maximum of five or six individuals. For example, representation from other local jurisdictions and university research centers could be considered as their role in the program increases. Either full voting membership or observer status could be offered depending on the specific role played by these organizations and commensurate with their financial or in-kind support of the IVHS activities.

Participation of the private sector in the policy board is more difficult to address. When major private sector corporations are involved in IVHS activities they are likely to require a role in the decision making processes. A distinction can be made between those private sector organizations which are being paid for their services to the program (e.g., the Lockheed Corporation as Crescent Demonstration Operator in the HELP program) and those which are providing their own resources to support the program (e.g., General Motors in the PATHFINDER and TRAVTEK projects). In this latter case it is reasonable to view the particular private sector organization as a true partner in the project and to consider them for committee membership. It is likely that private sector membership will be evaluated on a case-by-case basis.

The final potential participant in each U.S. component of ENTERPRISE will be the U.S. Department of Transportation, through the FHWA. It is very probable that federal funding will be sought for the various state-level initiatives. With the current national interest in IVHS it is likely that any federal funding assistance will be accompanied by a desire for involvement in the program activities. In this case, the HELP program serves as an excellent model where federal involvement at the policy level is limited to an oversight role through ex-officio membership, while more active participation of the federal government is seen through membership on lower tier technical groups.

Key to the proposed state-level organizational structure will be an executive management group, responsible for the day-to-day management and coordination of activities within the program. Again, initial management input will be drawn

primarily from DOT personnel. It is recommended that a broader cross-section of disciplines are represented through a background advisory committee structure, to ensure that the full range of skills are available for developing the program and to assist in consensus building within the Department. In Arizona, for example, potential advisory committee members include Deputy Directors from Transportation Planning and Highways Divisions; representatives from the Transportation Research Center and Information Services Group; a Contracts Administrator; and a Purchasing Officer. Equivalent personnel would provide similar input to other state-level components of ENTERPRISE. Support from outside the Department, particularly from the Office of the Attorney General, would also be utilized. Other membership from outside the Department, such as local jurisdictions, university research centers, the private sector, and the federal government should also be considered in the interests of smooth information flow and conflict minimization.

The executive management group will have the greatest range of responsibilities. These will include the following:

- * approval of technical workplans;
- * approval of requests for proposals;
- * approval of contractor selections;
- * approval of contractor's work;
- * approval of program budgets and overall workplan updates;
- * approval of staffing and training plans;
- * negotiations and approval of private sector organizations' participation; and
- * recommendations to the policy board.

Additionally, the executive committee will provide one representative as each participant's link to GALACTIC, the multi-state bridging project, and by that means will participate in the broader ENTERPRISE initiative.

It is recommended that the executive group include a full-time program manager, responsible for ensuring that the day-to-day technical and administrative activities are being performed correctly. The HELP program model once again demonstrates the value of this position, particularly in providing a central point of contact for all program activities. Additionally, a management consultant will be appointed to the group to provide staff support and technical expertise to the program manager.

The executive management group will be served by working subgroups with specifically defined areas of responsibility. This approach allows subgroup members to fully utilize their expertise in particular areas and therefore provide the maximum degree of competent support to the executive manager.

The composition of subgroups will be dependent on the projects and activities developed for the particular state-level program. However, in general, the following types of subgroups are likely to be included in the structure:

- * Technical subgroups. These will take responsibility for coordinating the work in particular IVHS technology areas or for specific projects. The subgroups take decisions on IVHS research, testing and implementation approaches to be pursued in accordance with the agreed program; will review draft requests for proposals and new contractor responses within their particular technical areas and make recommendations for approval and selection by the executive management group; and will monitor contractors' technical progress and make recommendations on acceptance of deliverables. Technical subgroups will also take responsibility for standardization activities and evaluation procedures.
- * Staffing and training subgroup. This subgroup will be responsible for identifying the ongoing staffing needs at the DOT to support the internal IVHS program. The subgroup will make recommendations to program management on staff recruiting policy, including the timing of hiring new personnel. Additionally, this subgroup will make recommendations on continuing education and training needs of DOT employees to meet the challenges of IVHS.
- * Policy subgroup. This subgroup will have a number of responsibilities, including public awareness and outreach activities; liaison with related domestic and overseas IVHS activities; addressing legal issues; and considering issues which relate to possible policy changes, for recommendation to the executive management.

The recommended organizational structure for state-level components of ENTERPRISE is illustrated in Figure 10.1.

10.4 Organizational options for GALACTIC

This section of the report outlines an approach directed toward management and organization of the GALACTIC program. As the bridging program for the ENTERPRISE initiative, GALACTIC will provide the required elements of coordination and liaison between the various program participants. ENTERPRISE itself will have no organizational elements, but will simply be an umbrella title for the cumulative IVHS efforts of the member organizations. The entire structure of ENTERPRISE will therefore be fully defined by the organizational framework of GALACTIC, together with its various constituent member structures.

An initial requirement for establishing GALACTIC will be for the ENTERPRISE participants to develop individual organizational structures. These will serve to coordinate and manage the IVHS activities particular to each state or province. It is anticipated that the organizational structure outlined in the previous section, proposed originally for the Arizona MIDAS program, will provide a suitable model upon which ENTERPRISE participants can base their organizational

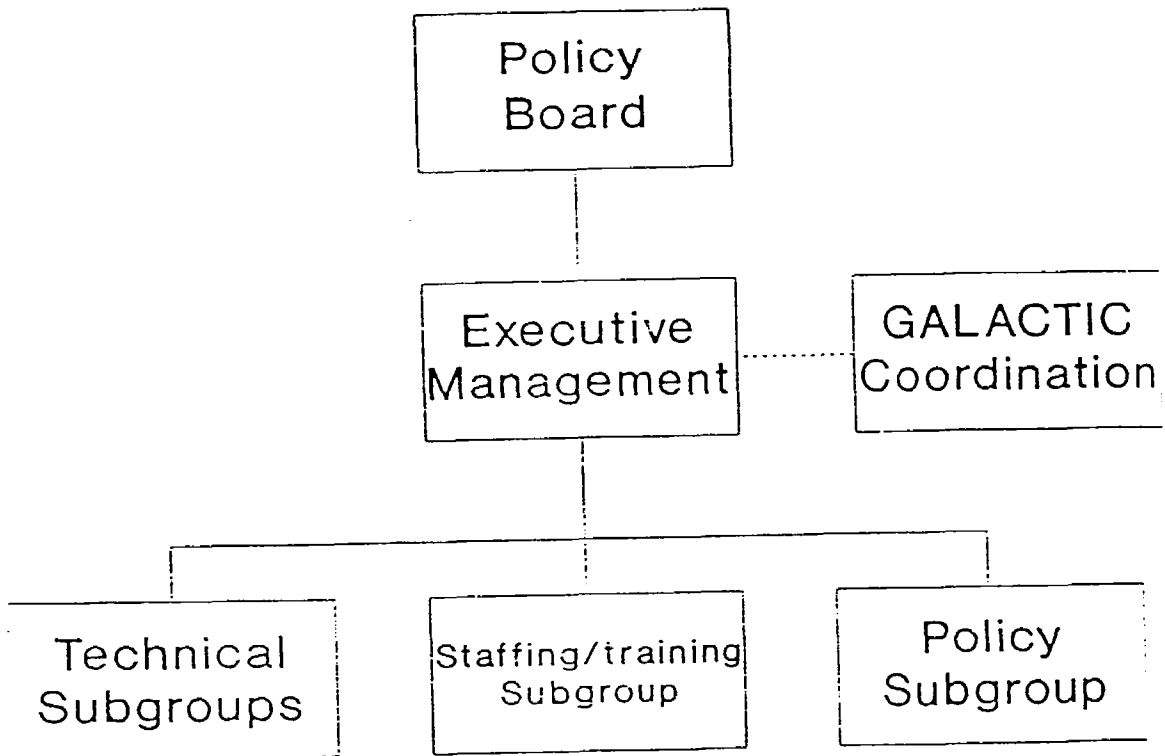

Figure 10.1 Proposed state-level organizational structure

structures. Some minor modifications may be required to suit individual situations, but in general the main characteristics of the structure should be applicable throughout the ENTERPRISE participants.

Following establishment of the individual program structures, the next stage will involve development of the GALACTIC organizational structure. This will be similar to the approach advocated for the state-level programs. At the highest level, it is recommended that overall responsibility for GALACTIC should be placed with an Executive Board. This will comprise one representative from the Executive Management Group of each ENTERPRISE participant. A selected representative will act as Chairman of the Executive Board. The Executive Board may also wish to appoint a GALACTIC program manager and management consultant, in a similar approach to that advocated for the state-level efforts.

The principal role of the GALACTIC Executive Board will be to provide liaison and coordination between the various ENTERPRISE elements. The Board will be supported in this task by a number of committees, to which each participant will provide one representative. The main GALACTIC committees will be a Policy Committee, a Technical Direction Committee, and an Inter-GALACTIC Committee.

The responsibilities of the GALACTIC Policy Committee will be similar to those previously defined for the state-level policy subgroup. The Policy Committee will cover public awareness and outreach activities, legal issues, and issues relating to possible policy changes. The Policy Committee will also be responsible for the preparation of budgets for GALACTIC's administrative overhead, for review by the Executive Board.

The role of the Technical Direction Committee will be to maintain an overview of progress within individual elements of the ENTERPRISE initiative. The Committee will chart overall technical progress in various projects and activities, ensuring that the program remains on schedule and retains clearly defined technical objectives.

The Inter-GALACTIC Committee will address cooperation and liaison between the ENTERPRISE program and external IVHS activities. This will include other IVHS projects in the U.S. and Canada, as well as European, Japanese and other worldwide initiatives. Membership of this committee will be extended to include representatives from these external initiatives, where this is felt to be appropriate. However, membership of non-ENTERPRISE organizations will probably be limited to ex-officio status.

Finally, it is recommended that one of the ENTERPRISE participants should be selected to provide administrative services for GALACTIC. These will include organization of GALACTIC meetings, and responsibility for program budget issues. Arizona has volunteered to provide these services, and already has experience in a similar role in the HELP program.

10.5 GALACTIC funding

This section outlines an approach toward funding the GALACTIC bridging effort of the ENTERPRISE program. The recommended funding mechanism is based upon the approach adopted by the multi-state HELP program. Within the HELP program, each participating state provides a minimum contribution of \$25,000 using HPR sources. This is retained in a pool fund administered by the State of Arizona, which is subsequently used to cover program travel costs, technical studies, outreach efforts and management and policy consultant services.

The funding approach recommended for GALACTIC would closely follow the HELP mechanism outlined above. An annual contribution of \$25,000 is suggested as an appropriate level for each of the proposed ENTERPRISE participants. Again, this could potentially be obtained by the states from HPR sources, though an alternative mechanism will need to be approved for the Canadian elements of ENTERPRISE. The GALACTIC pool fund would then be used to cover a variety of costs, including the following:

- * travel and per diem costs for the ENTERPRISE participants;
- * administrative overheads and support services;
- * management and policy consultant services;
- * program outreach activities and promotional efforts; and
- * technical studies undertaken within the overall ENTERPRISE umbrella.

As outlined in the previous section, Arizona has already agreed to provide administrative support for the ENTERPRISE program. If this is agreed by the other program participants, ADOT would then become responsible for the recommended GALACTIC pool fund. ADOT would be well placed to perform this task, providing similar services as lead administrative state in the HELP program.

10.6 Summary

This chapter has described the development of an organizational structure for the state-level IVHS programs, and has indicated how these fit into the broader organization of the GALACTIC project and the ENTERPRISE initiative. The chapter considers a range of organizational issues and concludes that a structure should be developed as soon as possible which will emphasize both the testing and deployment of near-term technologies, as well as setting a research agenda for longer-term activities and ensuring public support for IVHS developments. The chapter defines a proposed organizational structure for state-level efforts based on selective executive and technical management groups. An outline organizational structure for the GALACTIC project is also presented, together with recommendations on funding for the GALACTIC effort.

11. SUMMARY

Traffic congestion is widely recognized as one of the most serious problems affecting metropolitan highway networks. Safety and environment are closely related areas of major concern. Projected increases in traffic are now so great that traditional approaches of road construction, demand management, and traffic control will not in themselves provide satisfactory solutions. Application of advanced technologies in areas such as motorist information and navigation systems, improved traffic control systems, and vehicle guidance systems has significant potential for relieving urban congestion and improving safety standards.

The range of advanced technologies that could help alleviate urban traffic congestion is very wide. Some of these technologies have substantially greater potential for addressing the congestion problem than others. Many of the technologies reviewed in Chapters 3 through 6 of this report offer other potential benefits, such as improvements in safety, reduction of environmental pollution, and improved driver comfort and convenience. Further development and demonstration of these Intelligent Vehicle-Highway Systems (IVHS) approaches is also confidently expected to create major economic benefits involving high-technology industry operating in a new high-growth consumer electronics market.

Through the ENTERPRISE initiative, proposed program participants have an opportunity to take a lead in demonstrating and implementing IVHS by taking part in a major, coordinated effort. The program will allow program members to undertake their own, internal IVHS projects in accordance with specific needs and interests. Cooperation and coordination within the program will ensure that activities are targeted toward common goals in an environment of mutual trust and benefit. This concept development report addresses the initial elements of the ENTERPRISE program by identifying potential partners, their roles and an overall structure for the initiative.

National and International Programs

Chapter 2 reviewed other, major international and national IVHS research and demonstration programs currently in progress. Two major conclusions were drawn from the experience of programs elsewhere. The first is that IVHS must be considered in terms of a single, world market. Active, well-coordinated and meaningful links to complementary overseas initiatives will provide an essential base for an economically effective IVHS program.

The second factor is based on the success of the multi-center, public-private cooperative frameworks of the European DRIVE and PROMETHEUS programs. Separate and fragmented individual state programs will not be as effective in meeting the challenge of IVHS as are coordinated programs such as HELP. Thus, interstate cooperation with joint project planning and development are essential requirements at high levels of the IVHS program.

Advanced Traveler Information Systems

Advanced Traveler Information Systems (ATIS) aim to provide motorists and transit passengers with in-vehicle information on congestion, traffic, weather, and transportation system conditions. Many technologies have been developed which can provide drivers and passengers with this information. ATIS systems are recommended as a high priority of the ENTERPRISE program because

- (1) they offer major economic development opportunities by opening up new consumer electronics markets, through equipping North America's fleet of over 160 million vehicles;
- (2) the real-time traffic information they provide will create significant benefits of reduced congestion and enhanced safety, by alerting travelers in advance of traffic problems; and
- (3) the advanced mobile communications links which will be developed in support of ATIS systems provide the key to IVHS breakthroughs across the whole spectrum of advanced vehicle technology programs.

Advanced Traffic Management Systems

Advanced Traffic Management Systems (ATMS) differ from traditional traffic control systems in two major respects. First, they are responsive to actual traffic flows, and second, they operate in real time. Proposed ENTERPRISE participants such as Arizona, Minnesota and New York are already at the forefront of ATMS research and implementation through projects such as the Phoenix Freeway Management System, GUIDESTAR and INFORM. Integration of these major ATMS developments with the new ATIS technologies will create further, substantial benefits, and is a cornerstone of the ENTERPRISE proposal. ATMS projects covering expert systems and interactive traffic control approaches are also recommended for consideration within other elements of the ENTERPRISE initiative.

Advanced Vehicle Control Systems

One way to improve drivers' ability to cope with increasingly demanding traffic conditions more efficiently and safely is through the use of intelligent driver support systems and automatic control devices. Advanced vehicle control systems (AVCS) can assist drivers in performing routine vehicle control functions, and could eventually relieve the driver of some or all of the control tasks. The application of these advanced systems is expected to result in greater safety, improved performance consistency and increased traffic throughput.

The application of AVCS has potential for by far the greatest gains in traffic performance of any IVHS technology area. The widespread use of these technologies could have a major effect, not only on congestion and safety, but on society's whole perception of automobile travel. Of course, the barriers to

be overcome before the technologies can be implemented are correspondingly more substantial. A major commitment to a medium and long-term program is therefore required in order to realize this quantum improvement in highway safety and operational performance. This will be provided by the contribution of the State of Arizona to the cooperative ENTERPRISE effort.

Fleet Management and Control Systems

The category of Fleet Management and Control Systems (FMCS) incorporates a number of technologies from the other principal IVHS areas, applied specifically to the needs of fleet operations. FMCS therefore have the potential to substantially improve the efficiency, safety and convenience of a range of vehicle fleets. These include trucking operations, transit vehicles, parcel delivery firms and emergency services vehicles.

The Heavy Vehicle Electronic License Plate (HELP) program has for the last six years led North American initiatives in areas such as vehicle-roadside communications, distributed data networks and onboard computers. HELP's ongoing activities include implementation of the Crescent Demonstration and development of a two-way, high-speed AVI beacon system. The inclusion of a number of HELP participants in the ENTERPRISE group will therefore provide a firm foundation of state-of-the-art technologies on which to build. Among other proposed ENTERPRISE participants, the inclusion of the Province of Ontario will offer substantial opportunities for the development of FMCS technologies for application on transit fleets.

ENTERPRISE Program Development

Chapter 7 addressed the establishment of the cooperative ENTERPRISE effort, into which a number of state-level IVHS programs will be integrated. The chapter identifies proposed program participants, outlining their ongoing and planned activities in the field of IVHS. A summary of the need for a coordinated multiparticipant IVHS initiative is also presented. The chapter goes on to outline a series of projects and activities for consideration by the proposed ENTERPRISE program participants. These will cover a range of technologies and approaches in a coordinated approach toward IVHS advancement.

Chapter 8 presents an illustration of preparatory work in the development of a state-level IVHS program plan. This is based upon the development of the MIDAS program for the State of Arizona. The chapter covers the development of ongoing initiatives in the state that can be integrated with future IVHS projects as well as identifying potential test sites for IVHS technologies. Similar activities could usefully be undertaken by other participants in the ENTERPRISE program.

Chapter 9 provides an overview of the main aspects of the MIDAS proposal for the Arizona state IVHS initiative. This is presented as a model for review by other state or provincial personnel responsible for developing similar internal IVHS program plans. These will then represent the various component programs of the

broader ENTERPRISE initiative. The chapter considers potential areas of benefit to both public and private sectors, before going on to set out a proposal for constituent elements of MIDAS, over a ten-year period. Chapter 9 also summarizes the potential benefits to highway users of the main technical areas included in MIDAS. The chapter concludes with the main requirements for development of state-level programs that can be identified from the MIDAS illustration.

Chapter 10 addressed the organizational structure that must be developed for the various state-level elements of ENTERPRISE, locating the power to make decisions at those levels of the public-private partnership where individuals are knowledgeable and competent. Effective decision-making requires authority to be vested in streamlined executive and technical management groups, whose membership should rarely exceed four to six people. The heart of the state-level organization structure will be the executive management group, including a full-time project manager and management consultant. Technical subgroups will report to this executive group, making decisions on particular projects and project areas within the agreed overall program. This quasi-private sector management approach will avoid any trend toward institutional paralysis which can prevent larger and more complex committee structures from moving forward quickly.

Chapter 10 also developed a structure for the broader ENTERPRISE program and its bridging project, GALACTIC. ENTERPRISE will be coordinated by an executive board comprising one representative from each program member. The executive board will be supported by committees responsible for policy, technical direction and coordination with non-ENTERPRISE efforts. Costs of the initiative will be covered by a GALACTIC pool fund, with contributions from each of the program participants.

Concluding Remarks

Based on this study, and on compelling evidence from earlier North American work, from Europe and from Japan, we believe that an unparalleled opportunity exists to make major impacts on twenty-first century problems of highway congestion, safety and environment. The ENTERPRISE program outlined in this report will enable its participants to establish a position of leadership in IVHS, both within North America and throughout the world. ENTERPRISE will assure the participants' citizens and commerce of key roles in world IVHS markets, as well as helping support a North American highway transportation system truly optimized to meet the challenges of the third millennium.

Before these benefits can be realized, however, there are a number of activities that need to be undertaken in the final stages of implementing the ENTERPRISE program. These can be summarized as follows:

1. A final team of states, provinces and other organizations needs to be established as the basis of the ENTERPRISE group. These should reach an agreement on the overall philosophy and objectives of the ENTERPRISE program.

2. Representatives of the final ENTERPRISE participants should seek formal approval to participate in the initiative and to commit required funds to the GALACTIC bridging effort.
3. The ENTERPRISE participants should develop programs for their IVHS activities, as the basis for their technical contributions to the effort. IVHS program plans should identify component projects and schedules, and will be used to support funding requests, to establish collaborative ventures, and to identify suitable private sector participants.

Although some of the proposed ENTERPRISE participants have already developed or commissioned IVHS programs, others are at a less advanced stage. These organizations could prepare programs independently, or could alternatively undertake a combined planning effort. Programs would probably best be developed through a consultant services approach, such as that represented by Minnesota's GUIDESTAR program or the Arizona MIDAS study.

4. Participants should establish suitable organizational structures for their internal IVHS activities. A model state-level organizational approach is included within this report.
5. Agreement should be reached on the organizational approach proposed for the ENTERPRISE program, via its GALACTIC bridging project. Participants should also appoint representatives for involvement in GALACTIC activities.
6. The participants should formally select an administrative state for GALACTIC and an overall program manager.

REFERENCES

- 1 King, G.F. Economic assessment of potential solutions for improving motorist route following - final report. KLD Associates, Huntington, NY, 1986.
- 2 King, G.F. and Mast T. Excess travel: causes, extent and consequences. Paper presented at 66th Annual TRB meeting, Washington DC, 1987.
- 3 Jeffery, D.J. The potential benefits of route guidance. Transport and Road Research Laboratory Lab Report 997, Crowthorne, UK, 1981.
- 4 Lunn, S.E. Route choice by drivers. Transport and Road Research Laboratory. Supplementary Report 374, Crowthorne, UK, 1978.
- 5 Jeffery, D.J. Options for the provision of improved driver information systems: the role of microelectronics and information technology. IEE Digest No. 1985/11, London, 1985.
- 6 Wootton, H.J. and Brett, A.C. Route information systems - signposts of the future? Proc. Second International Conference on Road Traffic Control, 15-17, IEE, London, 1986.
- 7 Olderbing, H.B., Brownlow, J. and Kolias, V. Driver information systems. Interim Report on DRIVE project V1024, July 1989.
- 8 Giffen, M. An automatic route-planning and mapping system. Proc. of Universities' Transport Studies Group Annual Meeting, Birmingham, UK, 1985.
- 9 Sandoval, V. The advent of information technology in road transport in France. Proc. of PTRC Seminar on Information Technology in transport and tourism, University of Bath, 1987.
- 10 Jeffery, D.J. Route guidance. Information Technology Applications in transport, Chapter 14. VNU Science Press, Utrecht, Netherlands, 1986.
- 11 Gardner, D. Time to take the right road to information. Surveyor, 12-13, June 1987.
- 12 Versnel, T. Information technology in tourism. Proc. of PTRC seminar on information technology in transport and tourism, University of Bath, 1987.
- 13 Mammano, F.J. Driver information and motorist aid hardware. IEEE transactions on vehicular technology, vol vt-29, no. 2, 161-173, May 1980.
- 14 Turnage, H.C. Highway advisory radio. IEEE transactions on vehicular technology, vol vt-29, no. 2, 183-191, May 1980.

- 15 Turnage, H.C. Development of automatic highway advisory radio in the United States. Proc. of international conference on road traffic signalling, 156-158, IEE, London, 1982.
- 16 Braegas, P. and Zechall, W. Influencing traffic today - the entire technical concept for the future. Internal document, Bosch-Blaupunkt, 1985.
- 17 Transport and Road Research Laboratory. Report of the working group on the broadcasting of traffic information. Supplementary Report 506, Crowthorne, UK, 1979.
- 18 JHK and Associates. Automatic Radio Information (ARI) - Application in Europe and the US. Summary record of the conference on in-vehicular motorist information systems, sponsored by FHWA, Office of Research, 1984.
- 19 Giesa, S. and Everts, K. ARIAM : Car-driver radio information on the basis of automatic incident detection. Traffic Engineering and Control, June 1987, 344-348.
- 20 Schneider, H.W. ARIAM - a car-driver radio information system with automatic text arrangement and display. Proc. of international seminar on electronics and traffic on major roads - technical, reglementary and ergonomic aspects, Commission of the European Communities, Paris, June 1985.
- 21 McEwan, D. Radio in the '80s - broadcasting and the ideal sound receiver of the future. Wireless World, vol. 83, 36-40, May 1987.
- 22 European Broadcasting Union. Specification of the radio data system (RDS) for VHF/FM sound broadcasting. Document Tech. 3244-E, EBU, Brussels, 1984.
- 23 French, R.L. Intelligent vehicle/highway systems in action. ITE Journal, November 1990.
- 24 Federal Highway Administration. Request for proposals number DTFH61-90-R-00030, December 1989.
- 25 French, R.L. Historical overview of automobile navigation technology. Proc. of 36th IEEE vehicular technology conference, Dallas, TX, May 1986.
- 26 Jeffrey, D.J. Electronic aids to vehicle navigation - an overview. IEE Digest no. 1987/21, London, 1987.
- 27 Department of Defense/Department of Transportation. Federal radionavigation plan. Washington DC, 1984.
- 28 Powell, C. Performance of the Decca Navigator on land. IEE Proceedings Vol. 129, part F, No. 4, 241-248, August 1982.

- 29 Stansell, T.A. The TRANSIT navigation satellite system. Magnavox company, Torrance, CA, 1978.
- 30 Stansell, T.A. The many faces of TRANSIT. Navigation, vol. 25, no. 1, Spring 1978.
- 31 Case, E.R. Overview of automobile navigation systems and potential applications. Paper presented at ITE Expo 86, 1986.
- 32 Moroney, M.J. The United States federal radionavigation plan. Paper presented at NAV 85 - Royal Institute of Navigation conference on land navigation and location for mobile applications, York, 1985.
- 33 French, R.L. Automobile navigation : where is it going? Proc. of IEEE position location and navigation symposium, Las Vegas, NV, 1986.
- 34 Lemonick, M. Now driving by satellite. Science Digest, 92, 34, 1984.
- 35 Tagami, K. Takahashi T. and Takahashi, F. Electro Gyrocompass, new inertial navigation system for use in automobiles. SAE technical paper series no. 830659, 1983.
- 36 Honey, S.K. and Zavoli, W.B. A novel approach to automotive navigation and map display. Proceedings of IEEE COMPCON 86, San Francisco, 1986.
- 37 Etak Inc. Publicity material and brochures. Menlo Park, CA, 1985.
- 38 Anon. Auto pilot. What Car? 51-53, January 1987.
- 39 Anon. Compact discs take on data storage. New Scientist, May 30, 1985.
- 40 French, R.L. and Lang, G.M. Automatic route control system. IEEE transactions on vehicular technology, vol. vt-22, no. 2, May 1973.
- 41 Everts, K. Keller, H. and Zackor, H. The economy of route guidance systems taking into account the state of development, a report to the German Federal Minister of Transport. Transport and Road Research Laboratory Translation 3240, Crowthorne, UK.
- 42 Pilsak, O. EVA - an electronic traffic pilot for motorists. SAE technical paper series no. 860346, 1986.
- 43 Thorpe, J. The PACE of progress. Motor, February 1, 1986.
- 44 Foster, M.R. Vehicle navigation using the Plessey Adaptive Compass. Proc. of NAV 85 - Royal Institute of Navigation conference on land navigation and location for mobile applications, York, 1985.
- 45 Plessey. Plessey automatic vehicle location systems - general description. Technical document PRS 3700, April 1987.

- 46 Ott, G.D. Vehicle location in cellular mobile radio systems. IEEE transactions on vehicular technology, vol. vt-26, no. 1, 43-60, February 1977.
- 47 Rosen, D.A. Mammano, F.J. and Favout, R. An electronic route-guidance system for highway vehicles. IEEE transactions on vehicular technology vol. vt-19, no. 1, 143-152, February 1970.
- 48 Stephens, B.W. Rosen D.A. Mammano, F.J. and Gibbs, W.L. Third generation destination signing: an electronic route guidance system. Highway Research Record no. 265, 1-18, 1968.
- 49 General Motors Research Laboratories and Delco Radio Division, GMC. A design for an experimental route guidance system. Report to FHWA under contract FH-11-6626, 1968.
- 50 Salas, G. Highway coding for route designation and position description. Highway Research Record no. 265, 31-49, 1968.
- 51 Ministry of International Trade and Industry, Agency of Industrial Science and Technology. The comprehensive automobile traffic control system: a general description of pilot test system. Tokyo, Japan, October 1977.
- 52 Yumoto N. Ihara, H. Tabe, T. and Naniwada, M. Outline of the CACS Pilot test Systems. Paper presented at the 58th annual meeting of the Transportation Research Board, Washington DC, January 1979.
- 53 Kobayashi, F. Feasibility study of route guidance system. Transportation Research Record 737, 107-112.
- 54 Association of Electronic Technology for Automobile Traffic and Driving (JSK Foundation). Information booklet. Tokyo, Japan, undated.
- 55 JSK Foundation. Tsukuba EXPO pilot test - automobile driving data collection/supply service system. Tokyo, Japan, undated.
- 56 Ministry of Construction and Highway Industry Development Organization. Road and automobile communication system. Tokyo, Japan, 1987.
- 57 Shibata, M. Experimental study on road/automobile communication system in Japan. Paper presented to OECD Scientific Expert Group MC5 third meeting, Tsukuba, Japan, June 2, 1987.
- 58 Braegas, P. Function, equipment and field testing of a route guidance and information system for drivers (ALI). IEEE transactions on vehicular technology, vol. vt-29, no 2, 216-225, May 1980.
- 59 Blaupunkt. ALI - Destination-Guidance System. Publicity brochure, 1986.
- 60 Von Tomkewitsch, R. Communication between information beacons and vehicles provided with infra-red equipment. Paper presented at seminar on microelectronics for road and traffic management, Tokyo, Japan, 1984.

- 61 Von Tomkewitsch, R. ALI-SCOUT - a universal guidance and information system for road traffic. Proc. of 2nd international conference on road traffic control, 22-25, IEE, London, 1986.
- 62 Sparmann, H.M., LISB route guidance and information system: first results of the field trial. Conference record of papers presented at the First Vehicle Navigation and Information Systems Conference, Toronto, Canada, 1989.
- 63 Jeffrey, D.J. Ways and means for improving driver route guidance. Transport and Road Research Laboratory report LR1016, Crowthorne, UK, 1981.
- 64 Chipperfield, J.L. An inductive loop based guidance system. IEE Digest no. 1985/11, London, 1985.
- 65 UK Department of Transport. AUTOGUIDE - a better way to go? Discussion document, London, 1986.
- 66 Anon. Guiding Light. Autocar, 96-97, 8 October 1986.
- 67 Jeffrey, D.J. Russam, K. and Robertson, D.I. Electronic route guidance by Autoguide. Proc. of PTRC seminar on information technology in transport and tourism, 211-224, University of Bath, 1987.
- 68 Catling, I. The London Autoguide demonstration scheme. Paper presented at the PTRC seminar on information technology in transport and tourism, University of Bath, 1987.
- 69 Davies, P. and Ayland, N.D. Current research efforts in automatic vehicle identification. Paper presented at SAE west coast meeting and exposition, Los Angeles, 1986.
- 70 Castle Rock Consultants. Heavy Vehicle Electronic License Plate System - feasibility study report. Arizona DOT, December 1984.
- 71 Castle Rock Consultants. Heavy Vehicle Electronic License Plate System - concept development study report. Arizona DOT, June 1985.
- 72 Castle Rock Consultants. Heavy Vehicle Electronic License Plate Program - executive summary. Arizona DOT, April 1989.
- 73 Catling, I. Automatic vehicle identification. Information technology applications in transport, chapter 3. WIM Science Press, Utrecht, Netherlands, 1986.
- 74 Hong Kong Transport Department. Electronic road pricing pilot scheme results brief. Consultation document, 1985.
- 75 Transpotech Ltd. Electronic road pricing pilot scheme - main report to Hong Kong Government. Hong Kong, May 1985.

- 76 Science Applications International Corporation. AVI/ETC demonstration program on the Caltrans San Diego-Coronado Bay bridge - final report. Caltrans, October 1986.
- 77 Castle Rock Consultants. Dulles Toll Road Fastoll Project - project summary. Virginia DOT, October 1988.
- 78 SAI Corporation. ARRTS system. Information brochure, 1984.
- 79 XCI Corporation. Automatic identification. Information brochure, 1986.
- 80 Organization for Economic Cooperation and Development. Reports from Seminar on Traffic Control and Driver Communication, held in Aachen, West Germany. OECD Road Research Program, Paris, France, January 1982.
- 81 Organization for Economic Cooperation and Development. Summary record of seminar on microelectronics for road and traffic management. Paris, October 1985.
- 82 Federal Highway Administration. Traffic control systems handbook. Revised edition, 1985. FHWA Office of Implementation, April 1985.
- 83 Clowes, D. Traffic control - the way forward. Proceedings of PTRC Annual Meeting. University of Warwick, 1984.
- 84 Davies, P. and Ayland, N.D. Urban traffic control - the next step forward. Paper presented at Transportation Research Board Annual Meeting, Washington DC, January 1988.
- 85 Jenkins, S.E. The role of traditional traffic control devices in the future. Paper presented at 13th Australian Road Research Board Annual Conference, August 1986.
- 86 Institution of Highways and Transportation. Roads and traffic in urban areas. Her Majesty's Stationery Office, UK, 1987.
- 87 Gartner, N.H. Demand-responsive traffic signal control research. Transportation Research, vol 19A, no. 516, pp 369-372, September/November 1985.
- 88 Allsop, R.E. Computer program SIGCAP for assessing the traffic capacities of signal-controlled road junctions description and manual for users. TORG Research Report No. 11.
- 89 Bang, K.L. and Nilsson, L.E. Optimal control of isolated traffic signals. 3rd International Symposium on Control of Transportation Systems, Columbus, Ohio, 1976.
- 90 Jezequel, R. Traffic control at an intersection by means of a microcomputer. 3rd International Symposium on Control of Transportation Systems, Columbus, Ohio, 1976.

- 91 Doherty, A.R. A comprehensive junction delay formulae. Working paper LTRI, 1977.
- 92 Pretty, R.L. Requirements for improved traffic signal calculations in relation to junction layout, capacity and delay. Transport Studies Group, UCL, 1979.
- 93 Webster and Cobbe. Traffic signals. TRRL Road Research Technical Paper no. 56, HMSO, London, 1966.
- 94 Federal Highway Administration. SOAP84 users manual. Implementation package FHWA-IP-85-7, 1985.
- 95 Vincent, R.A. and Young, C.P. Self optimising traffic signal control using microprocessors - the TRRL MOVA Strategy for isolated intersections. Traffic Engineering and Control, pp 385-7, July/August 1986.
- 96 Swedish National Road Administration. LHOVA, a new signal technique. SNRA TU155 (Extract), 1983.
- 97 Peterson, A., Bergh, T. and Steen, K. LHOVA - a new traffic signal control strategy for isolated junctions. Traffic Engineering and Control, pp 388-9, July/August 1986.
- 98 Schoene, G.W., Euler, G.W. and Wallace, C.E. Energy conservation through traffic signal timing optimization. Proc. of International Conference on Road Traffic Signalling, IEE, London, 1982.
- 99 Cimento, A.A. Traffic control systems hardware. IEEE Transactions on Vehicular Technology vol. VT-29 no. 2, May 1980.
- 100 Wallace, C.E. MAXBAND user's manual. FHWA Implementation package. FHWA-IP-87-1, January 1987.
- 101 Chang, E.C.P., Messer, C.J. and Marsden, B.J. Analysis of reduced delay and other enhancements to PASSERII-80 : PASSERII-84. Final Report. Texas Transportation Institute Report No. 375-IF, August 1983.
- 102 MacGowan, J. and Fullerton, I.J. UTES: Development and testing of advanced control strategies in the urban traffic control system. Public Roads, 43(2), 1979.
- 103 Robertson, D.I. TRANSYT : Traffic network study tool. Fourth International Symposium on the Theory of Traffic Flow. Karlsruhe, Germany, 1968.
- 104 Vincent, R.A., Mitchell, A.I. and Robertson, D.I. User guide to TRANSYT, Version 8. Transport and Road Research Laboratory Report LR888, Crowthorne, Berkshire 1980.
- 105 Robertson, D.I. Cyclic flow profiles. Traffic Engineering and Control, Vol 15, No. 14. 1974.

- 106 Holroyd, J. and Hillier, J.A. Area traffic control in Glasgow: a summary of results from four control schemes. Traffic Engineering and Control, volume 11, no. 5, pp 220-223, September 1969.
- 107 Transportation Research Center, University of Florida. TRANSYT-7F user's manual. Prepared for US Department of Transportation, Federal Highway Administration. University of Florida, Gainesville, FL, July 1987.
- 108 Transportation Research Center, University of Florida. National signal timing optimization project. Final evaluation report, initial demonstration phase. Contract No. DTFH61-C-80-00072. Gainesville, FL, December 1981.
- 109 California Energy Commission. Fuel-efficient traffic signal management: an action plan for California. Sacramento, March 1983.
- 110 Deakin, E.A., Skabardonis, A. and May, A.D. The fuel-efficient traffic signal management program : evaluation of first year activities. Research Report UCB-ITS-RR-84-12. Institute of Transportation Studies, University of California, Berkeley, October 1984.
- 111 Deakin, E.A. and Skabardonis, A. The fuel-efficient traffic signal management program: evaluation of the second and third funding cycles. Research Report UCB-ITS-RR-85-14. Institute of Transportation Studies, University of California, Berkeley, October 1985.
- 112 Institute of Transportation Studies, University of California. Fuel-efficient traffic signal management. Three years of experience, 1983-85. ITS Publications, Berkeley, 1986.
- 113 Bell, M.C. and Bretherton, R.D. Ageing of fixed-time traffic signal plans. Proc. 2nd Int. Conf. on Road Traffic Control. Institution of Electrical Engineers, London, April 1986.
- 114 Skabardonis, A. Estimating the impacts of signal hardware improvements. University of California. Accepted for publication in Transportation Research Record, August, 1987.
- 115 Luk, J.Y.K., Sims, A.G. and Lowrie, P.R. SCATS - Application and field comparison with a TRANSYT optimised fixed-time system proceedings. IEE International Conference on Road Traffic Signalling, London, 1982.
- 116 Rowe, E. ATSAAC Control center. Paper presented at the Arizona Department of Transportation Symposium on Freeway Surveillance and Control, Phoenix, Arizona, October, 1986.
- 117 Bretherton, R.D. Five methods of changing fixed-time signal plans. Transport and Road Research Laboratory Report LR 870, Crowthorne, Berkshire 1979.

- 118 Sims, A.G. and Dobinson, K.W. SCAT - the Sydney Coordinated Adaptive Traffic System. Philosophy and benefits. Paper presented at Int. Symposium on Traffic Control System, Berkeley, August 1979.
- 119 Sims, A.G. and Finaly, B.E. SCATS - Splits and offsets simplified (SOS). ARRB Proceedings, Vol 12, part 4, pp 17-33, 1984.
- 120 Luk, J.Y.K., Sims, A.G., and Lowrie, P.R. SCATS - Application and field comparison with a Transyt-optimized fixed time system. Int. Conf. on Road Traffic Signalling. Institution of Electrical Engineers, London, April 1982.
- 121 Hunt, P.B., Robertson, D.I., Bretherton, R.D., and Winton, R.I. SCOOT - a traffic-responsive method of coordinating signals. Transport and Road Research Laboratory Report LR1014 Crowthorne, Berkshire, 1981.
- 122 Andrew, C. An interview survey of motorway driver information requirements and signal understanding. Transport and Road Research Laboratory Report LR 742, Crowthorne, Berkshire, 1977.
- 123 De Kroes, J.L. and De Klein, S.J. The effects of motorway information systems. Verkeerskunde, vol 35, no. 11, pp 514-517, November 1984.
- 124 McDermott, J.M. Information systems for freeway operations. Arizona Department of Transportation Symposium on Freeway Surveillance and Control, Phoenix, Arizona, October 1986.
- 125 Russam, K. Motorway signals and the detection of incidents. Transportation Planning and Technology, vol 9, no. 2 pp 99-108, October 1984.
- 126 Golden River Corporation. GRID incident detection system. Information leaflet. Golden River Co., Bicester, Oxfordshire, England (undated).
- 127 New Civil Engineer. New MI signals forewarn of congestion. pp 4-5, October 2, 1986.
- 128 Elin Electronics. Elin on the road. Information leaflet, Elin Electronic Communications Division, Vienna, Austria (undated).
- 129 SCAN. All weather monitoring systems. Information brochure. Surface Systems Inc., St Louis, Missouri (undated).
- 130 Vaisala Traffic Safety Systems. ICECAST. Road condition monitoring system. Information brochure. Helsinki, Finland, 1987.
- 131 New Civil Engineer. Motorway control turns to computers. pp 20-21, January 24, 1985.

- 132 Klijnhout, J.J. Motorway control and signalling - operational experience in the Netherlands. Proc. 2nd Int. Conf. on Road Traffic Control, pp 31-34, Institution of Electrical Engineers, London, April 1986.
- 133 Klijnhout, J.J. Motorway control and signalling, the test of time. Traffic Engineering and Control, vol. 25, no. 4, pp 193-7, 1984.
- 134 Beukers, B. The Dutch motorway control and signalling system and its effect on road safety and traffic flow. Presented at the Seminar on Road and Traffic Management, Tokyo, October 1984.
- 135 Ahmed, S.A. Urban Freeway Traffic Management Technology. Journal of Transportation Engineering, ASCE, Vol 112, No. 4, July 1986.
- 136 Federal Highway Administration. Traffic control systems handbook. US Department of Transportation, Washington DC 1976.
- 137 McCasland, W.R. and Ibanez, J.H. Study of traffic-responsive ramp closure control. Texas Transportation Institute, Texas A&M University, College Station, Tx, 1972.
- 138 Inoue, N., Hasegawa, T. and Matsuo, T. Traffic control system on the Hanshin Expressway - further developments. Paper presented at the Engineering Foundation Conference on Traffic Control systems, Henniker, NH, 1987.
- 139 Hasegawa, T. Traffic control systems in Japan. Proceedings of the Engineering Foundation Conference on Research Directions in Computer Control of Urban Traffic Systems, pp 28-43, 1979.
- 140 Blumentritt, C.W. et al. Guidelines for selection of ramp control systems. NCHRP Report 232, Transportation Research Board, Washington DC, 1981.
- 141 McDermott, J.M. Chicago area freeway traffic management program. Illinois Department of Transportation. Division of Highways, District 1, September 1987.
- 142 McDermott, J.M. Freeway surveillance and control in Chicago area. Journal of Transportation Engineering, ASCE, Vol 106, No TE3, May 1980, pp 333-348.
- 143 Capelle, D.G. Freeway traffic management. NCHRP Project 20-3D, final report. Transportation Research Board, Washington DC, 1979.
- 144 Harvey, S.H. Ramp meters - an effective aid in controlling urban freeway congestion. Arizona Department of Transportation Symposium on Freeway Surveillance and Control, Phoenix, Arizona, October 1986.
- 145 Transportation Research Board. Freeway operations projects. Information Series No. 15, Transportation Research Board, Washington DC, 1982.

- 146 Case, E.R. and Williams, K.M. Queen Elizabeth Way freeway surveillance and control system. Transportation Research Record 682, pp 84-93. Transportation Research Board, Washington DC, 1978.
- 147 Nihan, N.L and Davis, G.A. Estimating the impacts of ramp control programs. Transportation Research Record 957, p31. Transportation Research Board, Washington DC 1984.
- 148 Duff, J.T. Accomplishments in freeway operations outside the United States. Highway Research Record 368, pp 9-25, Highway Research Board, Washington DC, 1971.
- 149 Wattleworth, J.A. & Wallace, C.E. Evaluation of the operational effects of an on-freeway control system. Highway Research Record 368, pp 26-32, Highway Research Board, Washington DC 1971.
- 150 Klijnhout, J.J. ADOT symposium on freeway surveillance and control. October, 1986.
- 151 UK Home Office. A study of motorway control rooms. Scientific Research Development Branch, Home Office, London, 1984.
- 152 Hodgson, W.C. Motorway communications systems in England - introducing a second generation. Proc. 2nd Int. Conf. on Road Traffic Control, pp 26-30, Institution of Electrical Engineers, London, April 1986.
- 153 Carvell, J.D. Jr, Dallas Corridor study. Texas Transportation Institute, Texas A & M Univ, College Station, Tx 1976.
- 154 Federal Highway Administration. Traffic control systems handbook. US Department of Transportation. Washington DC, 1976.
- 155 Zove, P. et al. Integrated motorist information system (IMIS). Feasibility and design study. Federal Highway Administration US Department of Transportation. Washington DC, 1978.
- 156 Saab-Scania. Scania ABS Brakes. Information leaflet, Sweden 1987.
- 157 Alfred Teves GmbH, ATE ABS MK 2. The world's first integrated anti-lock system. West Germany, 1987.
- 158 Grime, G. Handbook of road safety research. Butterworth and Co. (publishers) Ltd, 1987.
- 159 Pagel, E. Cruise control systems employed by Audi. Proceedings of Institution of Mechanical Engineers Conference on Automotive Engineering, 1979.
- 160 Bray, D. Intelligent Cruise Control. Topics of Research 2nd Prometheus Symposium, Brussels, Dec 1987.

- 161 Grimes, D.M. and Jones, T O. Automotive radar: a brief review. Proceedings of the IEEE Vol 63 No. 6, June 1974.
- 162 Hahn, L. Advances in the development of headway radar using pulse techniques. IMechE conference on automotive electronics, London, 1979.
- 163 Belohoubek, E.F. Radar control for automotive collision mitigation and headway spacing. IEEE transactions on vehicular technology vol. VT-31 no. 2, May 1982.
- 164 Lissel. Head control distance sensor. Topics of Research, 2nd Prometheus Symposium, Brussels. Dec 1987.
- 165 Cloup. Head Control Distance Sensor. Topics of Research, 2nd Prometheus Symposium, Brussels, Dec 1987.
- 166 Metzler. Video supported distance supervision. Topics of Research, 2nd Prometheus Symposium, Brussels. Dec 1987.
- 167 Bray, D. Vehicle following. Topics of Research, 2nd Prometheus Symposium, Brussels. Dec 1987.
- 168 Brinton, J. Radar braking is set for market debut. Consumer Electronics pp. 155-158. Jan 1970.
- 169 Flannery, J.B. Automatic braking by radar. Presented at SAE meeting. Detroit, Feb 1974.
- 170 Troll, W.C. Automotive radar brake. Presented at SAE meeting. Detroit, Feb 1974.
- 171 Futuretech. Briefing on smart cars/smart roads. Nos. 111 and 112, August 1990.
- 172 Mayhan, R.J and Bishel, R.A. A two-frequency radar for vehicle automotive lateral control. IEEE transactions on vehicular technology vol VT-31 no. 1, February 1982.
- 173 Gardels, K. Automatic Car Controls for Electronic Highways, General Motors Research Laboratories Report GMR-276, 1960.
- 174 Barrick, D. Automatic Steering Techniques," IRE International Convention Record, Volume 10, Part 2, pp. 166-178, 1962.
- 175 Hanson, M.E. (Ed.), Project Metran: An Integrated, Evolutionary Transportation System for Urban Areas, MIT Press, 1966.
- 176 Cardew, K.H.F. The automatic steering of vehicles - an experimental system fitted to a DS19 Citroen car. Road Research Laboratory Report LR 340, Crowthorne, 1970.

- 177 Shladover, S.E. Roadway Automation Technology - Research Needs. 68th Annual TRB Meeting, Washington, DC.
- 178 TRW Systems. Study of synchronous longitudinal guidance as applied to intercity automated highway networks. Prepared under contract to US Department of Transport, Contract no. C-353-66.
- 179 Fenton, R.E. et al. Fundamental studies in the automatic longitudinal control of vehicles. Transportation control lab. Ohio State University, Columbus, July 1975.
- 180 Metzler, H.G. Beck, P. Hausermann, P. and Kupke, M. Driver information system of the Mercedes-Benz research vehicle. Proceedings of the Institution of Mechanical Engineers Conference on Automotive Electronics, London, 1981.
- 181 Janicki, E. Computerized cars. Highway Patrolman pp. 4-11, June 1984.
- 182 Schmitt, L.A. Advanced vehicle command and control system (AVCCS). ASCE Journal of Transportation Engineering, Volume 116, No. 4, July/August 1990.
- 183 Wren, A. Software for bus operations planning. Information Technology Applications in Transport (Eds.: P. Bonsall and M. Bell), pp. 211-234, VNU Science Press, The Netherlands, 1986.
- 184 Philips Telecommunicatie Informatie Systemen 'BV. Philips Vecom Management and Control System for public transport, Publicity Brochure, undated.
- 185 Andersen Consulting. HELP on-board computer study. Final Report, April 1989.
- 186 Anon. Reading user black box technology to help reliability. Local Transport Today, p. 8, September 5, 1990.
- 187 Dowty Electronics. Videobus location system. Publicity brochure, undated.
- 188 Frenz, E. Optimisation of bus and tram with electronics'- how the Dutch do it. SRR 5 50-1717/82/AK, June 1982.
- 189 Philips Telecommunicatie Informatie Systemen BV. A trip around the world with Philips Vetag. Publicity brochure, The Hague, 1987.
- 190 Hart, I. Personal communication, August 1990.
- 191 Drischler, T. Personal communication, August 1990.
- 192 International Bridge, Tunnel and Turnpike Association. Toward AVI - summary report. AVI Briefing, Washington DC, February 1973.

- 193 Roth, S.H. Automatic vehicle monitoring technology review. The Mitre Corporation, Washington D.C., 1971.
- 194 Motorola Inc. Automatic vehicle location system. Information brochure, Schaumburg, IL, 1986.
- 195 Bronson, R. Sears, W. and Cortland, L. II Morrow's Loran C based vehicle tracking system. Proc. of NAV 85 - Royal Institute of Navigation conference on land navigation and location for mobile applications, York 1985.
- 196 II Morrow Inc. Information brochures. Salem, OR, 1986.
- 197 METS Inc. METS Tracker. Information brochure. Pompano Beach, FL, 1986.
- 198 GEC Traffic Automation Ltd. Tracker - Information leaflet. Borehamwood, UK, 1986.
- 199 Lert, P. Geostar's super satnav system. Professional Pilot, April 1984.
- 200 Lyles, R.W. and Lanman, M.H. Automatic vehicle monitoring: effective technique for transit system management and control. Transportation Research Record 854, 1982.
- 201 Anon. Ontario's new planning tool. Public Innovation Abroad, p. 4, September 1989.
- 202 Anon. Automatic vehicle location comes to Toronto. Metro Magazine. May/June 1987.
- 203 O'Neill, J. VIA looks to the future with AVM system. Metro Magazine, May/June 1989.
- 204 Wintrob, S. Toronto mass transit system tests instant communications. Computing Canada, October 27, 1988.
- 205 Philips Telecommunicatie en Informatie Systemen BV. TRANSMATION - automation for progressive public transport. Publicity brochure, 1988.
- 206 Collura, J., Rogers, A.D., and Warren, R.P. Computer assisted management information system for regional advance-reservation bus service. Transportation Research Record 863, 1982.
- 207 Benke, R.W. Videotex - transportation information systems. Pres. at the Northern Virginia Transportation Alliance Meeting, 1989.
- 208 U.S. Department of Transportation, Urban Mass Transportation Administration. Taxi-based paratransit technology/operations packages in Europe, May 1985.